



HELICOPTER FLIGHT TRAINING MANUAL

Second edition

June 2006

TC-1001888



© Her Majesty the Queen in Right of Canada, represented by the Minister of Transport (1996)

Permission is granted by the Department of Transport, Canada, to copy and/or reproduce the contents of this publication in whole or in part provided that full acknowledgment is given to the Department of Transport, Canada, and that the material be accurately reproduced. While use of this material has been authorized, the Department of Transport, Canada, shall not be responsible for the manner in which the information is presented, nor for any interpretations thereof.

TP 9982E
(06/2006)

TC-1001888

INTRODUCTION

This is the second edition of the Transport Canada Helicopter Flight Training Manual. The Manual has been prepared for the use of student pilots learning to fly, pilots improving their qualifications, and flight instructors in the conduct of instruction for student pilots. It provides information and direction in the introduction and performance of flight training manoeuvres as well as basic information related to flight training courses.

In preparing this manual, the objective was to provide progressive study material using basic terms and language aligned to pilot training at the elementary level. A working knowledge of the information contained in this manual will enable the student to receive maximum benefit from the air exercises.

It should be pointed out that the air exercises have been addressed in a logical suggested progression, but they can be adjusted to conform to any school's syllabus.

INTENTIONALLY LEFT BLANK

TABLE OF CONTENTS

INTRODUCTION	1
EXERCISE 1 - FAMILIARIZATION.....	1
FLIGHT INSTRUMENTS	2
ENGINE INSTRUMENTS	3
EXERCISE 2 - PREPARATION FOR FLIGHT	5
FLIGHT PLANNING	6
AIRCRAFT DOCUMENTS.....	6
WEIGHT AND BALANCE	7
THE INFLUENCES OF C OF G IN FLIGHT	7
INSPECTION OF THE AIRCRAFT	8
EXERCISE 3 - EFFECTS OF CONTROLS	10
ADJUSTING THE CONTROLS	10
CYCLIC STICK.....	10
COLLECTIVE LEVER.....	12
THROTTLE.....	12
TAIL ROTOR PEDALS	13
ANCILLARY CONTROLS.....	14
CARBURETTOR HEAT CONTROL AND MIXTURE CONTROL.....	14
WINDSHIELD DEFOGGING	17
ENGINE ANTI-ICING	17
HYDRAULIC SYSTEM	18
ROTOR BRAKE	18
HEATER	18
EXERCISE 4 - AIRSPEED AND POWER CHANGES STRAIGHT AND LEVEL FLIGHT	19
CHANGING AIRSPEED	19
POWER CHANGES.....	19
STRAIGHT AND LEVEL FLIGHT	20
EXERCISE 5 - CLIMBS AND DESCENTS.....	22
CLIMBS	22
DESCENTS.....	23
EXERCISE 6 - TURNS.....	24
LOAD FACTOR.....	25
STANDARD RATE TURNS.....	28
EXERCISE 7 - AUTOROTATIONS 1 (UPPER AIR)	29
CHECKS.....	29
ENTRY.....	30
TURNING	31
OVERSHOOTING.....	31

EXERCISE 8 - HOVERING	32
EFFECTS OF CONTROLS	33
THE CYCLIC	33
THE COLLECTIVE.....	34
THE PEDALS	34
VISUAL CUES.....	35
SUMMARY	35
EXERCISE 9 - TAKEOFF AND LANDING.....	36
TAKEOFF TO THE HOVER	36
HOVER CHECK.....	37
THE LANDING	37
EXERCISE 10 - HOVERING EXERCISES	38
PEDAL TURNS AT THE HOVER (TURNS AROUND THE MAST)	38
HOVER-TAXIING	39
EXERCISE 11 - ENGINE FAILURE	41
ENGINE FAILURE AT THE HOVER/HOVER-TAXI	41
HOVERING ENGINE FAILURE	41
HOVER-TAXI ENGINE FAILURE	41
EXERCISE 12 - TRANSITIONS.....	43
TRANSITION TO THE CLIMB.....	43
TRANSITION FROM STRAIGHT AND LEVEL FLIGHT TO HOVER.....	45
HEIGHT REDUCTION	45
SPEED REDUCTION	45
OVERSHOOTING FROM THE TRANSITION TO THE HOVER.....	46
EXERCISE 13 - AUTOROTATIONS 2 (LANDINGS)	47
POWER RECOVERY	48
EXERCISE 14 - EMERGENCIES.....	49
EXERCISE 15 - THE CIRCUIT	50
FLYING THE CIRCUIT	50
RACETRACK PATTERN.....	51
SQUARE PATTERN	52
SPACING	53
WAKE TURBULENCE	53
AIR TRAFFIC SERVICES (ATS).....	54
FIRST SOLO	54
EXERCISE 16 - SIDEWAYS AND REARWARDS FLIGHT.....	56
SIDEWAYS FLIGHT	56
REARWARD FLIGHT	57
TURNS AROUND THE TAIL.....	58
TURNS AROUND THE NOSE	58
EXERCISE 17 - STEEP TURNS	60

EXERCISE 18 - AUTOROTATIONS 3 (RANGE VARIATIONS)	61
AIRMANSHIP	61
EXTENDING THE RANGE	62
MAXIMUM RANGE AUTOROTATION	62
REDUCING THE RANGE	62
EXERCISE 19 - PRACTICE FORCED APPROACHES	66
DISTRESS CALL	67
EXERCISE 20 - PILOT NAVIGATION	68
PREPARING FOR THE FLIGHT	68
WEATHER.....	69
CHARTS.....	69
THE ROUTE.....	69
PREPARING THE CHART.....	70
THE FLIGHT PLANNING FORM	72
TRACK LINE MEASUREMENT	72
AIRSPEED CORRECTIONS.....	72
WIND VELOCITY (W/V)	73
NAVIGATION LOG	73
FLIGHT PLAN AND FLIGHT ITINERARY	74
GENERAL TECHNIQUE	74
MAP READING	74
THE FLIGHT.....	82
DIVERTING TO AN ALTERNATE DESTINATION.....	83
EXERCISE 21 - RAPID DECELERATIONS	88
INTO WIND	88
DOWNWIND (180° EMERGENCY TURN).....	89
EXERCISE 22 - LOW LEVEL OPERATIONS	91
CONSIDERATIONS	91
EXERCISE 23 - SLOPING GROUND	95
RECONNAISSANCE	95
MANOEUVRING	96
LANDING.....	96
TAKEOFF	97
GENERAL	97
EXERCISE 24 - ADVANCED TAKEOFFS AND LANDINGS	99
NO-HOVER TAKEOFF	99
CUSHION TAKEOFF.....	100
TOWERING TAKEOFF.....	100
VERTICAL TAKEOFF.....	101
NO-HOVER LANDING.....	102
RUN-ON LANDING.....	102
APPROACHES	102
EXERCISE 25 - CONFINED AREAS	103

EXERCISE 26 - VORTEX RING	107
EXERCISE 27 - PRACTICAL LOADING AND MAXIMUM WEIGHT OPERATIONS	109
POWER REQUIREMENTS	109
LOADING AND UNLOADING CARGO.....	109
PASSENGERS.....	109
EXERCISE 28 - SLING LOAD OPERATIONS.....	110
PRE-FLIGHT CHECKS.....	110
PICKING UP THE LOAD	112
THE TAKEOFF.....	112
APPROACH TO RELEASE POINT	112
RELEASING THE LOAD	113
SAFETY PRECAUTIONS.....	113
UNUSUAL LOADS.....	113
OPERATIONAL TIPS	115
EXERCISE 29 - TYPE CONVERSION	118
KNOWLEDGE	118
SYSTEMS AND PROCEDURES	118
PERFORMANCE	118
EXPERIENCE	119
EXERCISE 30 - INSTRUMENT FLYING	120
AIRCRAFT CONTROL	120
ATTITUDE CONTROL.....	121
POWER CONTROL.....	121
CONTROL AND PERFORMANCE INSTRUMENTS	122
PITCH ATTITUDE CONTROL.....	123
BANK ATTITUDE CONTROL.....	124
TRIM.....	124
THE RADIAL SCAN.....	125
APPLYING THE SCANNING PATTERN.....	125
INSTRUMENT EXERCISES	128
STRAIGHT AND LEVEL FLIGHT.....	128
CLIMB.....	128
DESCENTS.....	129
TURNS	129
UNUSUAL ATTITUDES.....	129
RULE OF THUMB:.....	130
EMERGENCIES/MALFUNCTIONS	130
EXERCISE 31 - NIGHT FLYING #1.....	131
PLANNING	131
CIRCUITS.....	132
EMERGENCIES.....	133
EXERCISE 31 - NIGHT FLYING #2.....	134
INTRODUCTION.....	134
PLANNING	134
EN ROUTE	134

EXERCISE 1 - FAMILIARIZATION

The first exercise will not normally involve any detailed training, but will consist of a flight during which your role as student will be mainly that of observer, even though you will occupy the seat from which you will subsequently fly. This flight will begin to accustom you to the sensation of flying, and to the appearance of the country from the air. However, it is the flight instructor's prerogative to take a more positive approach to instruction at this time, and may also include some part of Exercise 3: "Effects of Controls".

In preparation for this flight your instructor will first accustom you to the cockpit layout, including the flight and engine instruments (Fig 1-1 and 1-2). The arrangement shown is the most common but you may well find that the helicopter you are flying is slightly different.

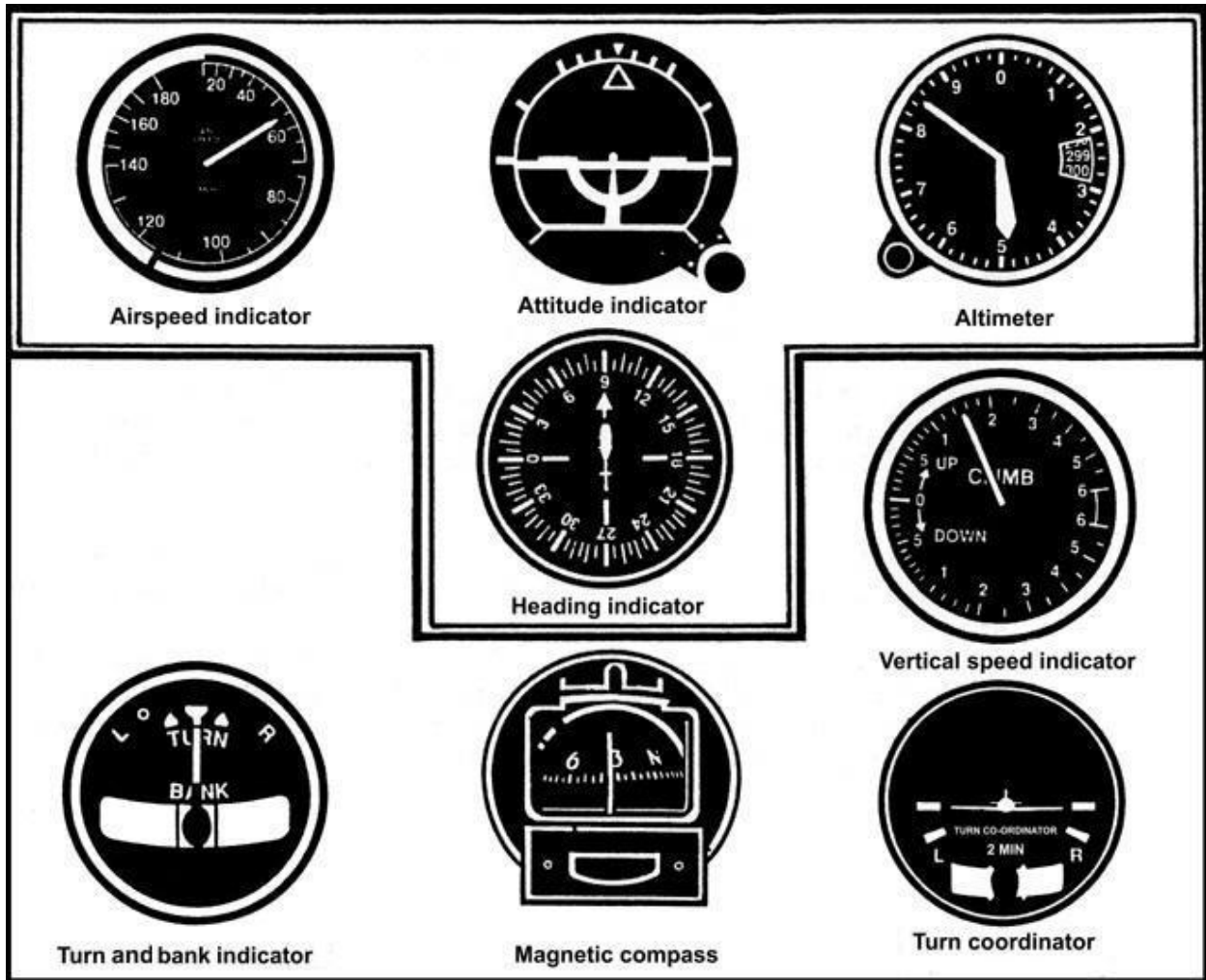

Figure 1-1: Flight Instruments

FLIGHT INSTRUMENTS

1. **AIRSPED INDICATOR.** This instrument indicates the speed of the helicopter through the air in which it is flying; it relates only indirectly to the speed of the helicopter over the ground. It may indicate speed in miles per hour or knots.
2. **ALTIMETER.** This is a pressure sensitive instrument that, if properly set, indicates the altitude at which the helicopter is flying. The customary procedure is to set the instrument so that it indicates height above sea level (ASL). When used this way the indication on the altimeter will be that of the elevation of the airport when the helicopter is on the ground.
3. **TURN AND BANK INDICATOR.** The needle portion of this instrument indicates whether the helicopter is turning, together with the direction and rate of turn. The ball portion of the instrument is fundamentally a reference for coordination of controls. In co-ordinated flight the ball will be centred in its curved glass tube. Instead of a turn and bank indicator the helicopter may be equipped with a turn coordinator, which provides basically the same information with a different display.
4. **MAGNETIC COMPASS.** This is the basic reference for heading information. The compass correction card indicates the corrected heading to steer to allow for compass deviation.
5. **HEADING INDICATOR.** This gyroscopic instrument has no magnetic qualities of its own and therefore must be set periodically by reference to the magnetic compass. Its main asset is that it provides a stable directional reference, and unlike the compass is relatively free from error during turns, acceleration, and deceleration in normal flight manoeuvres.
6. **ATTITUDE INDICATOR.** This is a gyroscopic instrument. It provides the pilot with an artificial horizon, which together with a miniature aircraft superimposed on its face enables the pilot to determine the aircraft's attitude relative to the real horizon.
7. **VERTICAL SPEED INDICATOR.** This is a pressure sensitive instrument, which indicates the rate at which the helicopter is climbing or descending in feet per minute.
8. **OUTSIDE AIR TEMPERATURE GAUGE.** This is not a flight instrument, but is a valuable aid to flight safety since its indications can help the pilot assess the possibility of icing conditions. The instrument usually registers outside air temperature (OAT) in both degrees Celsius and Fahrenheit.

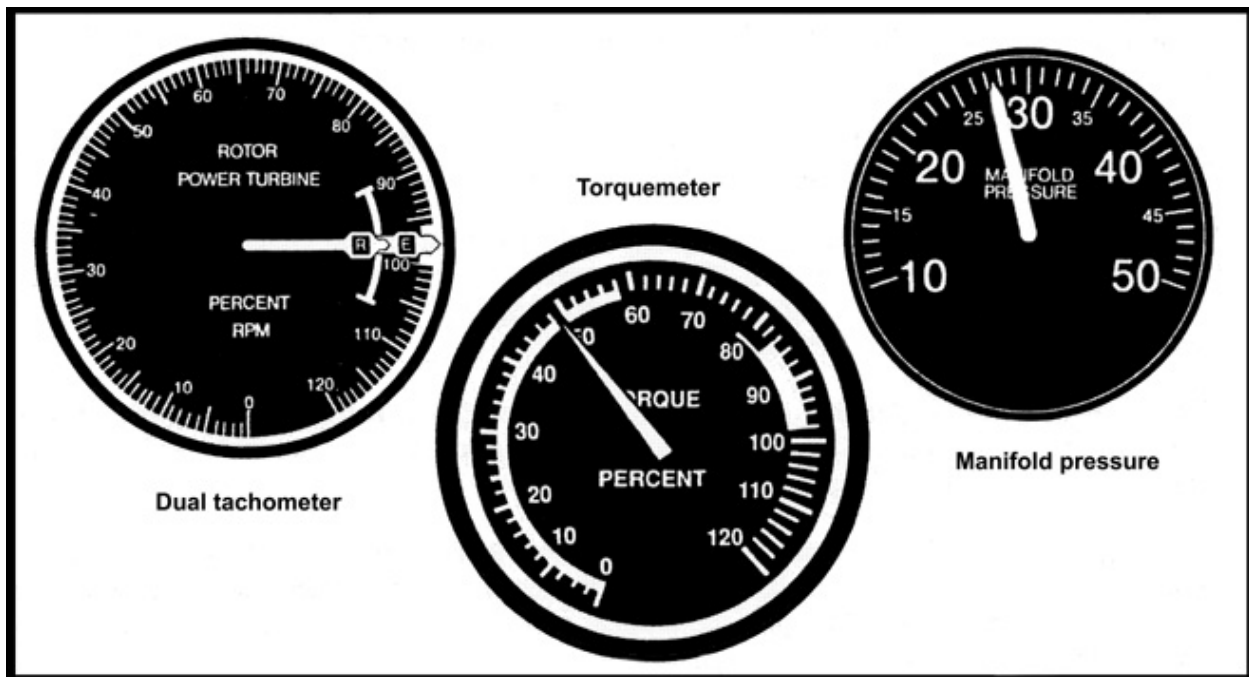

Figure 1-2: Engine Instruments

ENGINE INSTRUMENTS

1. **DUAL TACHOMETER.** This instrument indicates the number of revolutions per minute (RPM) that both the engine (ERPM) and the rotor blades (RRPM) are making. A separate needle is provided for each. In powered flight the needles are joined or 'married'. In autorotation the needles are split. A turbine-engined helicopter's dual tachometer is expressed as a percentage with 100% being the normal operating speed. (Fig 1-2).
2. **MANIFOLD PRESSURE GAUGE.** This instrument is calibrated in inches of mercury and indicates the pressure in the intake manifold of the engine. Stated more simply, it indicates the amount of work the engine is doing; the higher the manifold pressure (MP) the more work the engine is doing, and vice versa. This instrument will only be found on piston-engined helicopters.
3. **TORQUEMETER.** This instrument is the MP gauge equivalent on a turbine-engined helicopter. It is normally expressed as a percentage with 100% being the maximum available, but in some helicopters foot/pounds are the measure used.

There are several gauges that are vital to the operation of the engine that will be covered in detail by your instructor. All of these gauges indicate the temperatures and pressures (T's and P's) of the engine at any given time. There is a common method of marking the instruments with colour coding, but you should memorize the limitations for the helicopter you are flying. Refer to the helicopter flight manual for the limitations during any phase of engine operation.

The first flight will be an entirely new experience, but what may look complicated and difficult at this time will become less and less so as your flight training progresses.

You will be asked to keep your hands lightly on the cyclic stick and collective lever, and your feet lightly on the tail rotor pedals. The instructor will emphasise that only small, smooth movements are required to control the helicopter, and will briefly discuss procedures to be followed in future flight training exercises.

There will be a temptation for anyone who has never flown before to lean away from the bank as the aircraft turns. Resist this temptation as strongly as possible and attempt to become "one with the helicopter".

The instructor will point out readily identifiable local landmarks and explain their orientation to the heliport/airport. The function of the airspeed indicator and the altimeter will be explained, and periodically you may be asked to report the altitude and airspeed of the helicopter. The function of other instruments may also be explained.

Your instructor will explain the need for a positive handover and takeover of the flight controls. The person flying the helicopter will ensure that the other is on the controls before saying "You have control"; the person assuming control will then respond "I have control" and fly the helicopter.

The need for a constant and thorough lookout for other aircraft will be described, together with the clock method of reporting aircraft to the other crewmember. Do not hesitate to ask questions. The instructor's voice must be completely audible and clearly understandable; if it is not, tell him so.

EXERCISE 2 - PREPARATION FOR FLIGHT

This exercise does not normally involve a flight, but will acquaint you with the preparations necessary before commencing a flight. Proper pre-flight preparation plays a fundamental part in flight safety, and will reduce the possibility of accidents, or incidents.

The main components of the helicopter will be pointed out to you, and your instructor will subsequently provide a detailed explanation of each part (Fig 2-1).

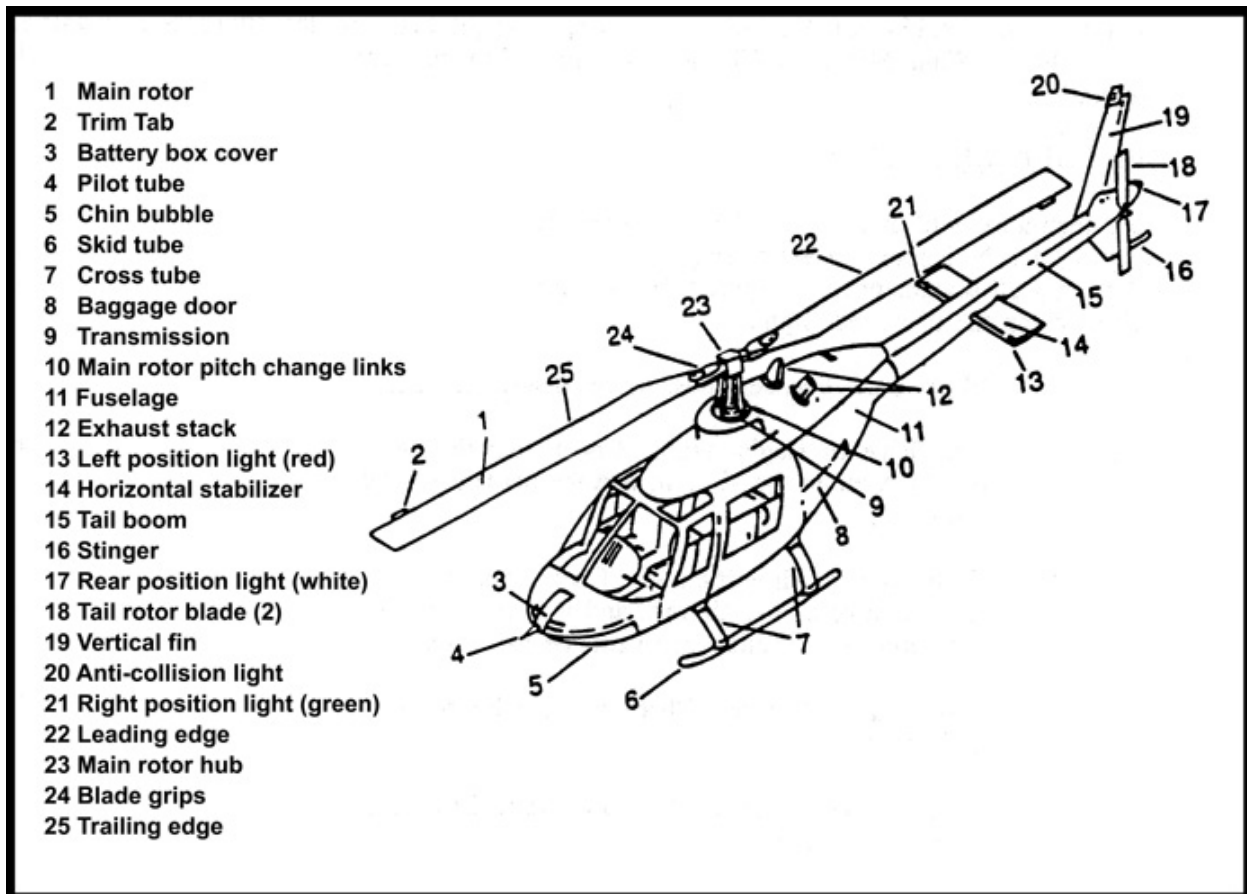

Figure 2-1: Main components of a helicopter

You may consider the sequence of events leading up to the takeoff as falling into three phases:

1. Flight planning,
2. Checking of aircraft documents,
3. Inspection of the aircraft, and the completion of necessary checks and procedures.

FLIGHT PLANNING

During your initial stages of training, your instructor will include the flight planning stage in your pre-flight briefings, but as the course progresses you will participate more fully in this aspect of preparation for flight. This will include the checking of weather reports and forecasts to extract information appropriate to the intended flight and the destination. Selecting the route, the checking of NOTAMs, preparing a flight log, and the filing of a Transport Canada Flight Plan or Flight Itinerary are also components of flight planning.

AIRCRAFT DOCUMENTS

Your instructor will show you all the documents, which must be on board the helicopter on every flight. It is the responsibility of the pilot-in-command to ensure that all documentation required for an aircraft and its crew is on board and/or current and valid for the proposed flight.

1. Flight crew licences must be on board the aircraft during any flight time.
2. Radiotelephone Operator's Restricted Certificate (Aeronautical) has to be carried by the pilot-in-command for use of radio transmitting equipment installed in the aircraft.
3. Certificate of Registration. Check that the nationality and registration marks are the same as the aircraft, and the name and address of the owner are properly inscribed.
4. Certificate of Airworthiness. Check that the nationality and registration marks are the same as the aircraft, and it is in force. Airworthiness is determined by checking that required maintenance has been completed.
5. Aircraft Journey Log Book. Check that it is the correct one and that the appropriate airworthiness entries and certifications have been made. Your instructor will explain under what circumstances this can be left at base.
6. Aircraft flight manual.

Logbook entries are the responsibility of the pilot-in-command who ensures they have been entered in the correct manner to record the events of the flight. Each period between a takeoff and a landing is generally considered a flight requiring a separate log entry.

Your instructor will explain exceptions to this rule, the significance of each document, and how to check each for validity.

Before any flight, the pilot-in-command of an aircraft must ensure that:

1. The aircraft documents required by the Canadian Aviation Regulations to be on board the helicopter are valid and/or properly certified.
2. The helicopter's weight and C of G are within allowable limits with the proposed fuel, occupants, and baggage.

WEIGHT AND BALANCE

The maximum weight limitations are set by the structural capabilities of the helicopter, an allowance being made for the extra forces encountered in turbulence and extremes in control movements.

The centre of gravity is defined as a location where all of the aircraft's weight is considered to be concentrated. Improper balance of a helicopter's load can result in serious control problems. The centre of gravity has quite a limited range of movement. The range of movement of the cyclic control system sets this limit (Fig 2-2).

THE INFLUENCES OF C OF G IN FLIGHT

CG AFT LIMIT (TAIL-LOW)

When the CG is aft, the cyclic is in the forward position. With a tail-low attitude, you need even greater forward displacement of the cyclic while hovering into the wind. If the helicopter exceeds aft CG limits, hovering is not possible. Takeoff and landing in the strong headwind conditions may be critical, because you need greater forward cyclic to hover as well as levelling off after a flare on an autorotation approach.

CG FORWARD LIMIT (NOSE-LOW)

When the CG is forward, the cyclic is in the aft of the neutral position. With a nose-low attitude, you need excessive rearward displacement of the cyclic control to maintain a hover in a no-wind condition. You should not continue flight in this condition, since you could rapidly run out of rearward cyclic control as you consume fuel. In the event of engine failure and the resulting autorotation, you may not have enough cyclic control to flare properly for the landing.

LATERAL OFF-BALANCE

The cyclic will be displaced opposite to the position of the load. This is more noticeable if litters are being used. For slope operations, care must be taken and you must prevent the static/dynamic roll over situations.

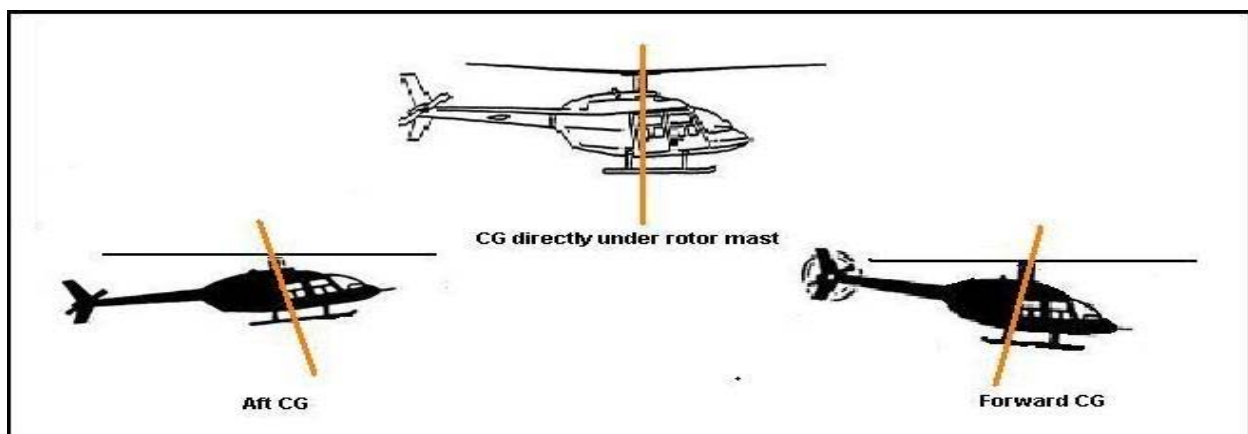

Figure 2-2 Centre of gravity

INSPECTION OF THE AIRCRAFT

It is the responsibility of the pilot-in-command to ensure that an aircraft is safe and fit in all respects for the intended flight. The pre-flight external inspection determines, from the pilot's point of view, that the aircraft is serviceable and that it has sufficient fuel and oil for the intended flight. Your pre-flight inspection should follow a set pattern and sequence. In this way, no items will be forgotten and your sequence will be similar no matter what type of helicopter you fly in the future. Most manufacturers recommend that you begin at the nose, on the right hand side to finish at the point you started. (Fig 2-3). Having completed the external inspection in this fashion you are ready to enter the cockpit. A recommended method of conducting this inspection is found in most helicopter flight manuals.

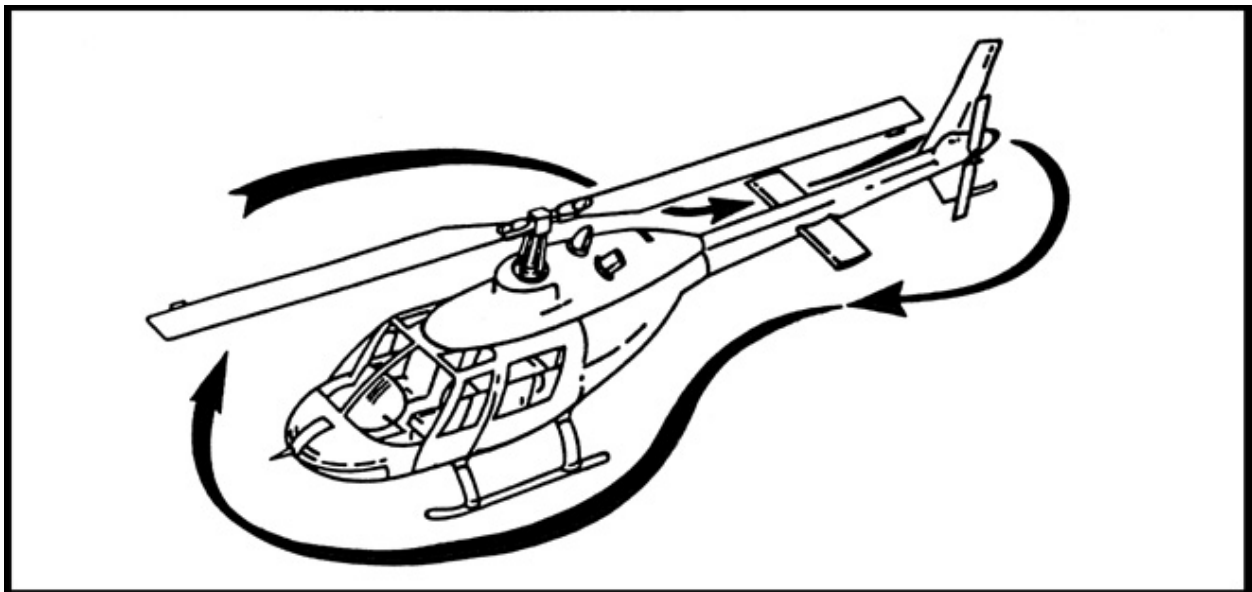

Figure 2-3: Pre-Flight Inspection

While walking out to the helicopter you should take note of the strength and direction of the wind, and the presence of any other aircraft, or obstacles, which may affect the starting procedures or the subsequent takeoff.

Your instructor will teach you the correct procedures for briefing your passengers at this stage.

Where possible, the helicopter should be positioned into wind, clear of any obstructions to main and tail rotor blades, with a fire extinguisher available. It is discourteous and may be hazardous to start a helicopter close to buildings or vehicles, as damage may be caused by the rotor downwash as the helicopter lifts into a hover. Light aircraft parked nearby may suffer substantial damage to their control surfaces.

Your instructor will demonstrate a pre-flight inspection and explain what you should look for to determine the airworthiness of the helicopter. If during this inspection you discover an un-serviceability, or have any doubts about the helicopter's airworthiness, then it should not be flown. All schools have a system of reporting defects. It could well be just to inform your own instructor, but do not be afraid to express your doubts to an engineer.

Before starting the engine, a thorough cockpit and “pre-start” check utilising a checklist shall be performed. Completion of these checks using the checklist is very important, and should be conducted in accordance with the recommended procedures contained in the helicopter flight manual. This pre-flight check will ensure that components are not damaged through incorrect starting procedures. Using the appropriate checklist, all further checks, such as starting, warm-up and run-up, if applicable, should likewise be performed in accordance with the manufacturer’s recommendations.

Following the flight you must once again, using a checklist, follow the recommended procedure for engine cool down, and shutdown. Your instructor will demonstrate the correct starting and shutdown procedures during this exercise. As your course progresses you will learn to perform these procedures on your own, using the checklists that should be provided by your school.

EXERCISE 3 - EFFECTS OF CONTROLS

In this exercise you will learn the range of attitudes through which the helicopter will normally be operated and how the controls are used to achieve and maintain the desired flight attitudes. The skills learned in this exercise form the basis for all future helicopter air exercises.

Now that flight training has begun in earnest, start observing this rule: look around. For safety in flight, keep alert for other aircraft. Look out continually. Realise that there are blind spots behind and beneath your helicopter, and never assume that others have seen you. Be especially alert during nose-up attitudes of the helicopter when the blind spot enlarges due to a decrease in forward visibility.

A pilot must be constantly on the lookout for other aircraft and must keep up a continuing search of the sky. It is commonly believed that the eye sees everything in its field with equal clarity. This is not so. Fix your gaze about 5 degrees to one side of this page, and you will no longer be able to read the printed material. Studies have revealed that the eye perceives very poorly when it is in motion. Wide sweeping eye excursions are almost futile and may be a hazard, since they give the impression that large areas of sky have been examined. A series of short, regularly spaced eye movements is recommended for maximum efficiency in searching the sky.

ADJUSTING THE CONTROLS

Your instructor will demonstrate the correct adjustment of the flight controls in preparation for flight, and the correct use of the control frictions. Ensure that the pedals are adjusted so that you are sitting in a comfortable position, or you may find yourself becoming fatigued very quickly.

CYCLIC STICK

Moving the cyclic stick will tilt the rotor disc and cause the helicopter to either pitch or roll, or a combination of the two, effecting motion in the direction the cyclic is moved. Remembering that the total lift reaction is always perpendicular to the rotor disc, when the disc is tilted from the lift (vertical) component, the thrust (horizontal) component will cause the helicopter to move in the direction of rotor tilt. (See Figure 3-1). After the helicopter has been started your instructor will demonstrate how the disc reacts to cyclic control movements. Observe that the disc tilts in a direction corresponding to the direction in which you have moved the cyclic.

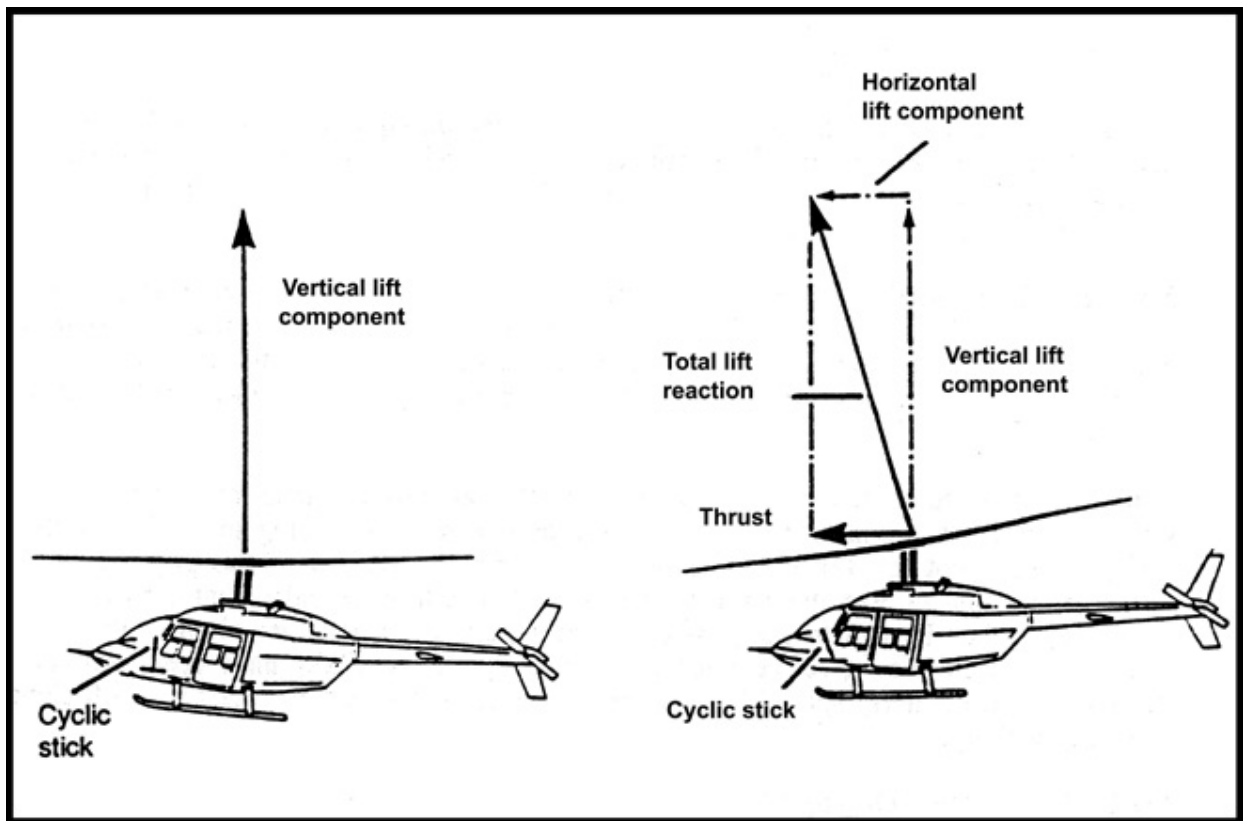

Figure 3-1: Total Lift Reaction

Notice that the total lift reaction is unchanged in magnitude, but the cyclic movement has changed the direction of that force, thus also affecting the attitude and airspeed of the helicopter.

Your instructor will demonstrate the effects of cyclic stick movement to maintain straight and level flight, as this is the basis for all attitude changes. To begin with, you should note the helicopter attitude by reference to the horizon, and your instructor will also point out the instrument indications in response to cyclic inputs. The cyclic stick controls the aircraft attitude and therefore the airspeed, which in turn affects altitude.

Fore and aft cyclic movement is used to achieve and maintain the desired attitude to select the airspeed. The amount and rate of attitude change varies with the amount and rate of cyclic movement. Lateral movements of the cyclic will produce and control rolling motion to establish and maintain desired angles of bank, or to restore the helicopter to a level attitude. Once again the amount and rate of roll varies with the amount and rate of cyclic movement.

Always move the cyclic smoothly and by small amounts. Be aware that abrupt control movements can reduce the life of components, and may even damage them.

COLLECTIVE LEVER

The collective lever is so named because when the collective is moved, it alters the pitch, or angle of attack, of all main rotor blades by the same amount at the same time. Raising the collective increases all main rotor blade angles of attack, resulting in an increase in the total lift. (Fig 3-2)



Figure 3-2: Collective Pitch

Decreasing collective will of course result in the opposite reaction. The primary effect of moving collective will be a change in height, and the secondary effect is a change in yaw.

THROTTLE

A twist grip throttle is mounted on the forward end of the collective. It is used to set the engine and rotor RPM to the normal operating range on piston engine helicopters. Your instructor will demonstrate that in addition to increasing RPM, applying throttle will also cause the manifold pressure to increase, and the helicopter to yaw to the right. Reducing throttle, while causing a decrease in RPM and manifold pressure, will again cause yaw, this time to the left. Your instructor will also demonstrate proper coordination of throttle, and collective movements, to maintain both manifold pressures, engine and rotor RPM in the correct operating ranges.

On most light turbine helicopters, the throttle is used to bring the engine up into the governed range, where precise adjustments of the engine and rotor RPM are made through the engine governor “beep” switch. Once set correctly, RPM will remain relatively constant regardless of collective movement. It is worth mentioning that some helicopters do not have a collective mounted throttle; some have the throttle on the floor, others on a roof console.

TAIL ROTOR PEDALS

The purpose of the pedal controlled tail rotor is to counteract the torque effect of the main rotor, to control the heading of the helicopter during hovering flight, and to initiate turns while in the hover. It is not, however, used to control the heading while in cruise flight, but only to compensate for torque. This puts the helicopter in longitudinal trim so as to maintain co-ordinated flight (Figure 3-3 refers). Some helicopters have a 'ball' to assist you to keep in co-ordinated flight. This is a simple spirit level device, if the ball is deflected to the right, apply right pedal until the ball centres and vice versa.

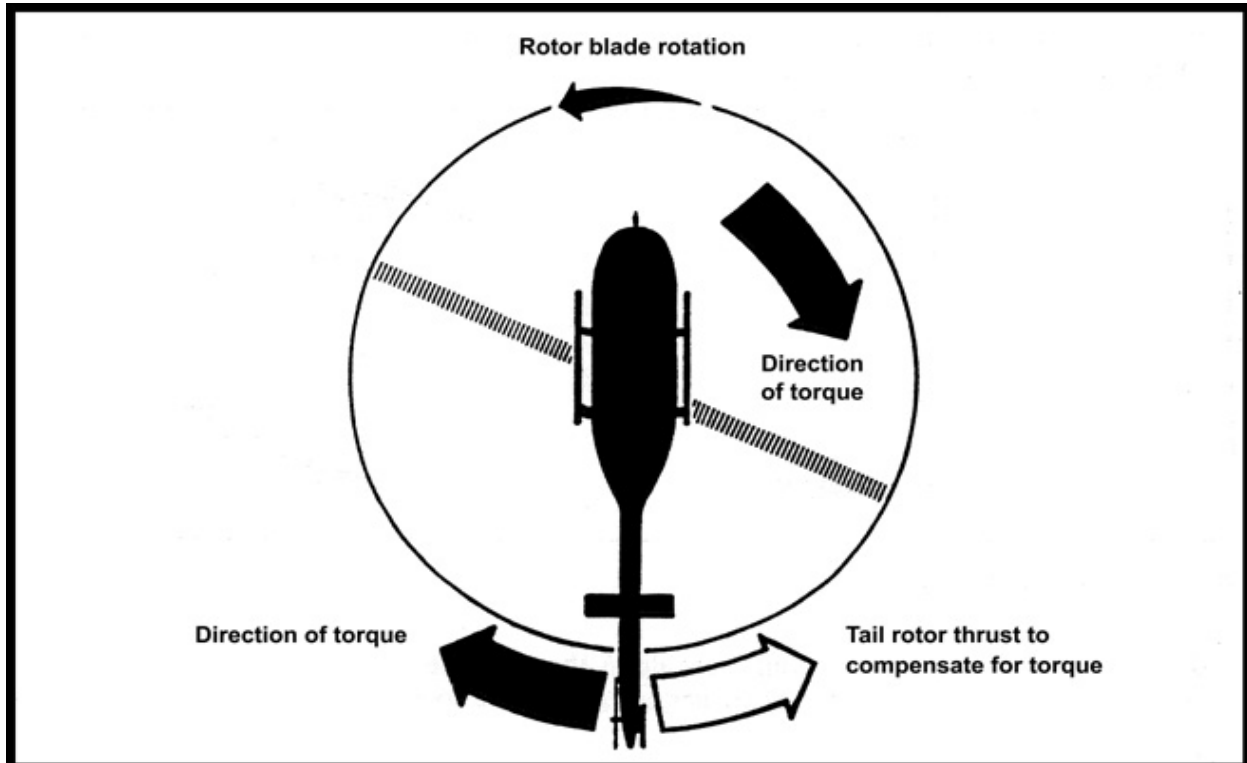

Figure 3-3: Torque Effect

Movement of the pedals will effect a change in the collective pitch of the tail rotor blades. The result of pressure on one pedal will be a yaw in the corresponding direction, i.e.; pressure on the left pedal will cause the nose to yaw left, and vice versa. An increase in pitch will require an increase in power, a decrease in pitch a decrease in power. On North American helicopters the left pedal is the "power" pedal. In other words when you apply left pedal you will require more power.

Your instructor will demonstrate to you that the need for pedal application must be anticipated every time you change power. In fact, any change in collective or cyclic position will require you to adjust the pedals in order to maintain co-ordinated flight.

ANCILLARY CONTROLS

These controls, while not actually used to control the helicopter in flight, are nevertheless vital to the safe and comfortable operation of the helicopter. Depending on helicopter type, ancillary controls may include: carburettor heat, mixture control, engine anti-icing, windshield defogging, rotor brake and heater. Your instructor will demonstrate the correct use of the particular ancillary controls that equip the type of helicopter on which you will be training.

CARBURETTOR HEAT CONTROL AND MIXTURE CONTROL

CARBURETTOR HEAT CONTROL

Carburettor Icing. Under certain moist atmospheric conditions, with air temperatures ranging anywhere from -13 degrees Celsius to +38 degrees Celsius, (Fig 3-4) it is possible for ice to form in the induction system (Fig 3-5).

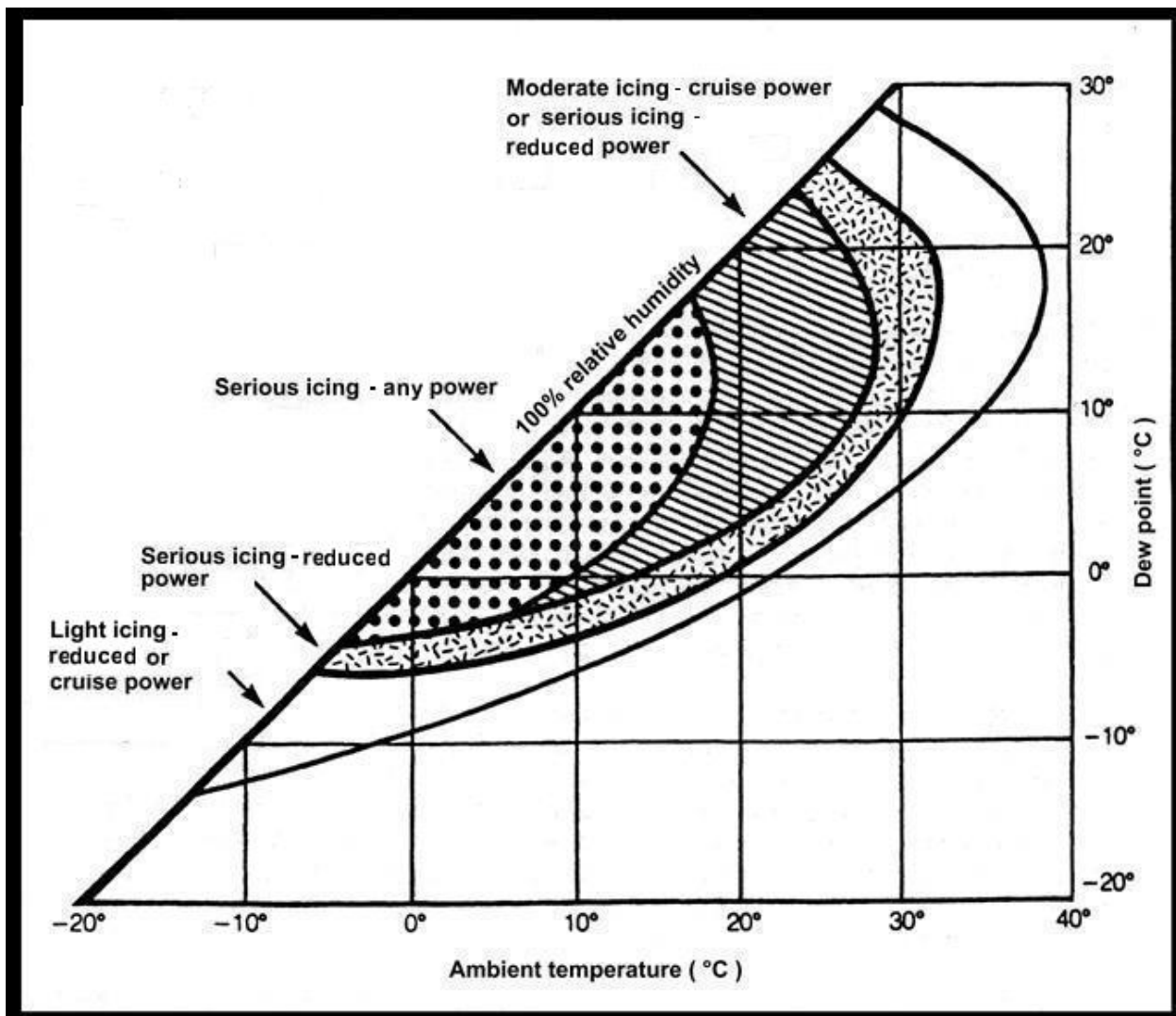

Figure 3-4: Carburettor Icing Graph

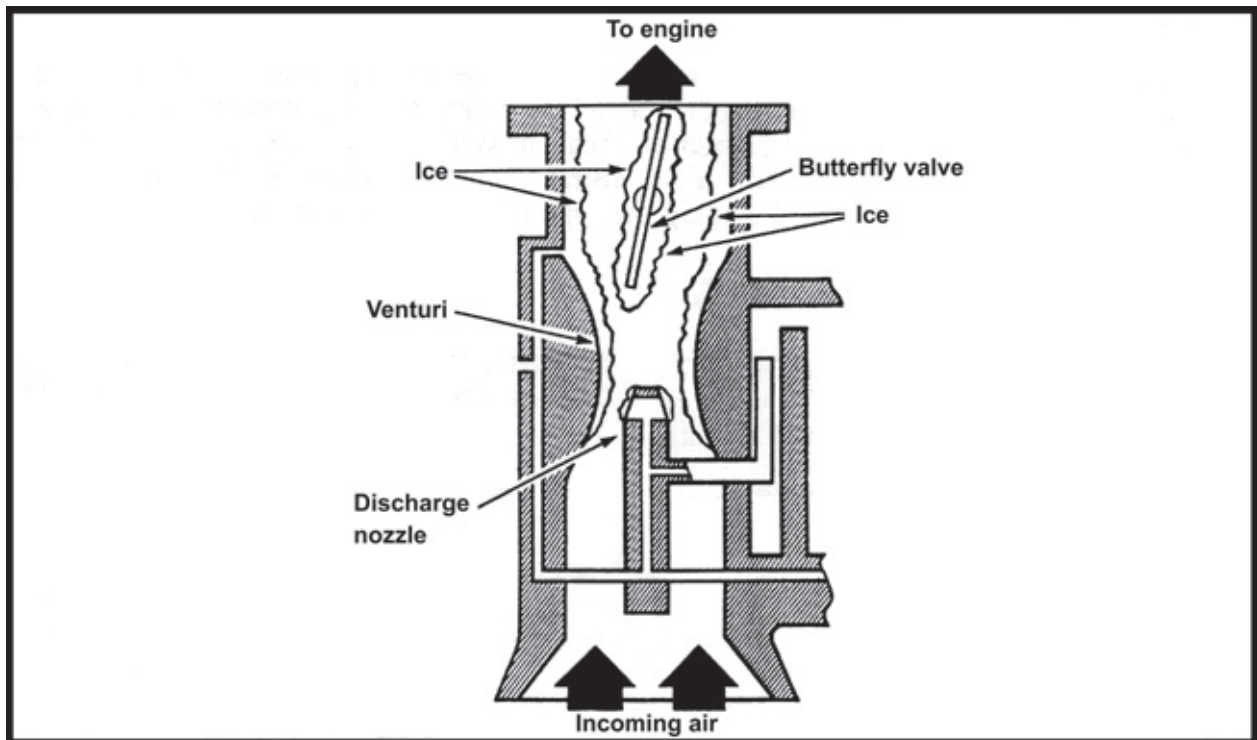

Figure 3-5: Carburettor Icing

The rapid cooling in the induction system using a float type carburettor is caused by the absorption of heat from the air during vaporisation of the fuel. It is also due in part to the high expansion of air through the carburettor venturi. As a result of the latter two influences, the temperature in the venturi may drop as much as 21 degrees Celsius below the temperature of the incoming air. If this air contains a large amount of moisture, the cooling process can cause ice to form. This may build up to such an extent that a drop in power output results, and if not corrected may cause complete engine stoppage. Indications of icing to the pilot are a loss of manifold pressure together with engine roughness. To prevent the formation of carburettor ice piston engine helicopters not using fuel injection are equipped with a controllable system for preheating the air before it enters the carburettor. They are also equipped with a gauge, which aids in the prevention of carburettor ice.

Carburettor Heat. Normally you can anticipate possible icing by checking the carburettor heat gauge and use carburettor heat before the ice forms. However, should ice begin to form use the "full heat" position long enough to be sure of eliminating the ice. Using full heat will initially cause a loss of power and possible engine roughness. Heated air directed in the induction system will melt the ice, which goes through the engine as water, causing some of the roughness and more power loss. Despite this temporary roughness and attendant moderate power loss, a pilot is not damaging the engine at a cruise power setting of 75 per cent or less with any amount of heat.

When using carburettor heat, there are related factors to remember. The engine loses an average of 9 per cent of its power when heat is applied. This is due to the reduced volumetric efficiency of heated air and loss of the ram air feature. Carburettor heat also creates a richer mixture, which may cause the engine to run rough, particularly at full heat. Increase power to the former setting until the engine runs smoothly again.

Carburettor icing may be controlled, or avoided, by adopting the following practices:

1. Start the engine with the carburettor heat control in the “cold” position, to avoid damage to the carburettor heat system.
2. When relative humidity is high and the summer ambient temperature is below 27 degrees Celsius, use carburettor heat immediately before takeoff. In general, carburettor heat should not be used while hovering because of increased power requirement.
3. Avoid using carburettor heat during takeoff since it may cause detonation and possible engine damage. An exception to this might be in very low temperature areas, which call for special procedures.
4. Remain alert after takeoff for indications of carburettor icing, especially when visible moisture is present. Remember that the relative humidity approaches 100% close to the base of clouds.
5. When carburettor ice is suspected, immediately apply full heat. Watch for a power loss to indicate the presence of carburettor heat, then an increase in power as ice melts.
6. Carburettor icing can occur with the ambient temperature as high as +38 degrees Celsius and humidity as low as 50 per cent. Remain especially alert with a combination of ambient temperature below +28 degrees Celsius and high relative humidity. The possibility of carburettor ice decreases:
 - a) in the range below 0 degrees Celsius, because of lessened humidity as the temperature decreases,
 - b) at around -10 degrees Celsius because of ice crystals which pass through the indication system harmlessly. It should be remembered that if the intake air does contain ice crystals, carburettor heat might actually cause carburettor icing by melting the crystals, and raising the moisture-laden air to the icing temperature.
7. During low power descents, when carburettor icing is present or suspected, apply full carburettor heat and adjust collective, so that enough engine heat is produced to prevent or disperse ice. This is a general rule for many helicopters. Consult the flight manual for the procedures in a specific helicopter type.

There is a misconception that it does not matter, to the efficiency of the engine, whether the carburettor heat is on or off. If this were true, engine manufacturers would design their engines so that heated air was constantly directed through the carburettor air intake system to completely eradicate the problem of carburettor icing. But they don't because the application of carburettor heat in standard atmospheric conditions will:

1. Reduce the maximum power output of the engine, and
2. Increase fuel consumption.

As the ambient temperature decreases, the effect of carburettor heat on the efficiency of the engine also decreases. Light helicopter engines, operated at extremely low (winter) ambient temperatures, may require the warming influence of carburettor heat to ensure adequate response to throttle application.

MIXTURE CONTROL

Most mixture adjustments are required during changes of altitude or during operations at high altitude. As an aircraft gains altitude, the surrounding air becomes less dense. At altitude, the engine draws a lesser weight of air into its cylinders than it does on the ground. If the weight of the fuel drawn into the cylinders remained the same, regardless of altitude, the mixture would become too rich at altitude.

To maintain the correct fuel/air mixture, you must be able to adjust the amount of fuel that is mixed with the incoming air. This is the function of the mixture control. This adjustment, often referred to as “leaning the mixture”, varies from one aircraft to another. Refer to the Approved Rotorcraft Flight Manual (RFM) to determine specific procedures for your helicopter. Note that most manufactures do not recommend leaning helicopters in flight. Generally, the accepted procedure for leaning the mixture is to move the mixture control slowly toward the “lean” position until maximum RPM is obtained with a fixed power setting. Then, move the mixture control toward “rich” until a decrease in RPM is just perceptible. This produces optimum power for the throttle setting, with a slightly rich mixture to prevent overheating, since sustained operations with the mixture too lean can damage the engine: high engine temperatures can cause excessive engine wear or even failure. The best way to avoid this type of situation is to monitor the engine temperature gauges regularly and follow the manufacturer’s guidelines for maintaining the proper mixture.

WINDSHIELD DEFOGGING

Although the windshield defogging system is not classed as an ancillary control, a phase of its operation is included in this exercise.

The windshield of a helicopter should at all times be kept clear and free of anything that will interfere with forward visibility, not only for control purposes, but also to see outside obstructions and other air traffic clearly. Under no circumstances attempt a takeoff with a fogged or partially fogged windshield. The windshield defogging system will generally keep the windshield clear of interior fogging when the helicopter is in flight. However, while hovering or waiting for takeoff, windshield fogging may occur. On these occasions, opening the vents or windows to improve interior air circulation may control fogging.

ENGINE ANTI-ICING

Most light turbine helicopters are equipped with an engine anti-icing system operated by engine bleed air. This system is controlled by an electrically operated valve, and directs hot bleed air to the intake of the compressor, to prevent ice accumulation on the front frame. This system does not have a de-ice capability and should be activated whenever the temperature is 4 degrees Celsius or less in visible moisture to prevent ice accumulation. Details regarding the correct operation of the system used on your particular helicopter will be found in the helicopter flight manual.

NOTE: *Light helicopters are not certified for flight into known or forecast icing conditions.*

HYDRAULIC SYSTEM

All medium and heavy helicopters and some light helicopters are equipped with hydraulically assisted flight controls. If the type you are training on is so equipped you will be taught how the system operates and emergency procedures associated with a failure. Most medium and light helicopters can be flown without hydraulic assistance but the controls become quite heavy. Heavy helicopters cannot be flown without hydraulic assistance so they are equipped with multiple systems for backup.

ROTOR BRAKE

Some light helicopters are equipped with a hydraulically operated rotor brake, which can be used by the pilot to rapidly decelerate the rotor after engine shutdown. The hydraulic system for the rotor brake is most often self-contained and not a part of the helicopter flight control hydraulic system. This type of system will have rotor RPM limits above or below which you should not apply the brake due to the possibility of damaging the drive train. This information will be found in the helicopter flight manual and is normally placarded in the aircraft and clearly marked on the rotor tachometer.

HEATER

Most light helicopters have a cabin heater, which may be one of several different types, including: engine bleed air, muff or "Casey", and combustion heaters. Your instructor will demonstrate the operation of the type of heater that is installed in your helicopter and brief you on the safety precautions regarding its use. Once again the helicopter flight manual will contain information on the operation of the heater.

EXERCISE 4 - AIRSPEED AND POWER CHANGES STRAIGHT AND LEVEL FLIGHT

Now that you have seen the effects of each control movement, you can begin to control airspeed and power and make precise changes. You can also begin to co-ordinate control movements in order to maintain balanced flight as airspeed and power changes take place, with all control movements concentrated on developing a smooth and accurate touch.

During this exercise you will make attitude changes looking at the horizon and then confirm the changes with the instruments. Avoid looking at the instruments for a long period of time.

CHANGING AIRSPEED

Your instructor will demonstrate changing airspeed by moving the cyclic and will point out to you both the resulting visual and instrument indications. To reduce speed from cruise to a specific airspeed for example, from 80 mph to 60 mph, ease the cyclic aft to select the attitude, hold the attitude, and finally adjust the attitude for accuracy. You will notice that the speed begins to decrease and the altitude increase. Concentrate for the moment on the airspeed, anticipate before you reach 60 mph, and adjust the cyclic to maintain that airspeed. Throughout these manoeuvres ensure that you maintain co-ordinated flight by preventing yaw with the tail rotor pedals.

To accelerate to specific airspeed ease the cyclic forward to select the attitude, hold the attitude, and then adjust for accuracy. This will increase the airspeed and the altitude will decrease. Pause to let the airspeed stabilize, anticipate the desired airspeed, and then adjust cyclic as necessary to maintain that airspeed. Once again prevent yaw through the use of the tail rotor pedals.

Your instructor will have you practise this several times. Attempt to make cyclic changes small and smooth, avoiding large or abrupt control movements.

POWER CHANGES

Your instructor will describe the relationship between collective and throttle movement as it applies to the helicopter on which you are training. You will note that any change in power causes the helicopter to yaw as a result of the changing torque. The greater is the change in power, the greater the torque effect. You must anticipate this torque reaction whenever changing power and make the appropriate pedal adjustment to maintain coordinated flight.

If training on a helicopter powered by a piston engine your instructor will explain and demonstrate the method of changing manifold pressure while maintaining a constant RPM. To increase the manifold pressure, you must raise the collective. This will increase the pitch on the main rotor blades. It will also cause a decrease in RPM due to increased drag. To prevent this undesired decrease in RPM, always lead with throttle. This action will now result in an increase in manifold pressure while maintaining RPM. Remember that these power changes will cause the helicopter to yaw unless you simultaneously apply corrections to the appropriate tail rotor pedal. On North American helicopters, an increase in power will require left pedal input, the 'power pedal', and a decrease in power, a right pedal input. On most European helicopters the right pedal is the power pedal.

To reduce the manifold pressure the opposite will apply. You will lower the collective. This reduction of blade pitch, with the resulting reduction in drag, will cause the RPM to increase. To prevent this increase you must reduce the throttle setting. This in turn will cause a decrease in manifold pressure, while maintaining RPM. Once again you must anticipate the need for an adjustment of the tail rotor pedals to prevent unwanted yaw.

Your instructor will demonstrate that to increase RPM you must increase the throttle and also reduce collective to maintain a constant manifold pressure. To reduce the RPM you will close the throttle slightly and raise the collective to maintain a constant manifold pressure.

Collective pitch is the primary control for manifold pressure while the throttle primarily controls RPM. But since one influences the other you must analyze both the dual tachometer to determine the RPM, and the manifold pressure gauge to determine the power, to decide which control to apply and by how much to get the expected results. For example: if the RPM were low and the manifold pressure low, you would increase the throttle, maintaining the collective setting. The result would be an increase in both RPM and manifold pressure.

The control movements on turbine and on some piston-engined helicopters (RH 22 / 44) are simplified in so far as the governor maintains the RPM. The movements of the collective and pedals are identical to a piston engine helicopter.

STRAIGHT AND LEVEL FLIGHT

We may define straight and level flight as flight at a constant altitude, on a constant heading, with a constant airspeed in co-ordinated flight. Small, smooth, coordinated control movements achieve this condition.

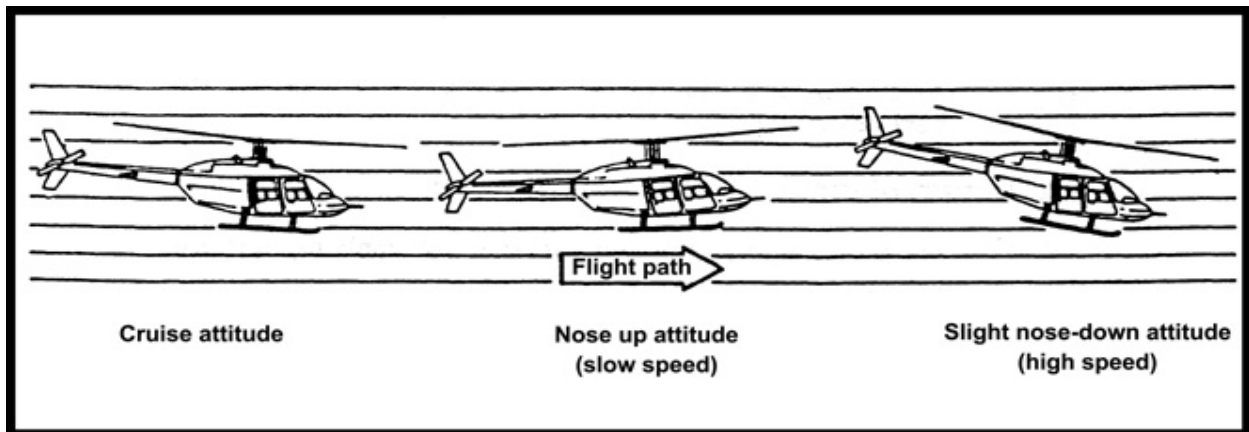

Figure 4-1: Attitudes In Level Flight

As you have seen, once the main rotor has been tilted, the fuselage will tend to parallel that tilt as the helicopter C of G aligns itself with the line of total lift reaction. Your instructor will point out to you the visual cues representative of straight and level flight at cruise airspeed and various other speeds. You should note the position of the disc, in relation to the horizon, as this is one of the important cues in cruise flight. Note also, the power settings used for cruise speed.

You will soon realize that airspeed varies with the attitude of the helicopter, and since the movement of the cyclic controls the attitude, we can say that the cyclic controls airspeed. Moving the cyclic aft will raise the nose of the helicopter and decrease the airspeed. Moving it forward lowers the nose and increases the airspeed. To maintain forward flight, the disc must be tilted forward to obtain the necessary horizontal thrust component; a nose-low attitude will result as the fuselage aligns itself with the drive axis and the airspeed increases. The lower the nose, the greater the power required maintaining level flight, and the greater the resulting airspeed. Conversely, the greater the power setting the lower the nose must be to maintain level flight.

In straight and level flight, increasing the collective while maintaining a constant airspeed with cyclic will cause the helicopter to climb. The opposite is also true. Decreasing the collective while maintaining airspeed with cyclic will result in a descent. Remember that these collective changes will require you to make pedal adjustments to maintain the helicopter in co-ordinated flight. To increase the airspeed in forward flight, you must apply forward cyclic, and raise the collective to prevent the helicopter from descending. To decrease the airspeed, apply aft cyclic, and decrease the collective to prevent the helicopter from climbing. We can examine a reduction in airspeed step by step:

1. select a slightly nose-high attitude by moving the cyclic aft;
2. reduce power to prevent the helicopter from climbing by lowering collective, and correlating throttle if appropriate to the helicopter type;
3. prevent yaw through use of the tail rotor pedals;
4. pause, allowing the airspeed to stabilize; and
5. adjust collective and cyclic as necessary to maintain the new desired speed.

Increasing the airspeed can be analyzed in the same way:

1. select a slightly nose-low attitude by applying forward cyclic;
2. increase power to prevent the helicopter from sinking by raising collective, correlating throttle if appropriate to the helicopter type;
3. prevent yaw through use of the tail rotor pedals;
4. pause, allowing the airspeed to stabilize; and
5. adjust collective and cyclic as necessary to maintain the new desired airspeed.

You may find that the cyclic is quite sensitive, but there will in fact be a slight delay between your input and the main rotor disc reaction, and thereafter the movement of the fuselage. You will learn to anticipate the required control movements to achieve certain desired airspeeds so as to avoid over-controlling. Making all your control inputs as smooth and precise as possible will assist in avoiding this pitfall.

NOTE: *In certain types of piston helicopter whenever the collective is raised or lowered the pilot must correlate the rpm with throttle. From Exercise 4 onward, although it still applies, the above statement has been omitted to save repetition.*

EXERCISE 5 - CLIMBS AND DESCENTS

Entering a climb or a descent will involve changes in attitude, airspeed, altitude, forward visibility and power settings. Your instructor will review with you the recommended climb and descent airspeeds and power settings for your helicopter type. In the case of most helicopters the recommended speeds are specified in the flight manual. Your instructor will emphasize accurate control of the helicopter, as this is vital to success in future air exercises.

CLIMBS

The best rate of climb speed is the airspeed that will afford the greatest gain in height in a given time. If it is important to reach a given altitude in the shortest possible time, this is the airspeed to use. The helicopter can be climbed at any airspeed within its operating limits, but the best rate of climb is obtained at the airspeed where power required for flight is at a minimum, and power available is near the maximum. Refer to the accompanying chart (Fig 5-1).

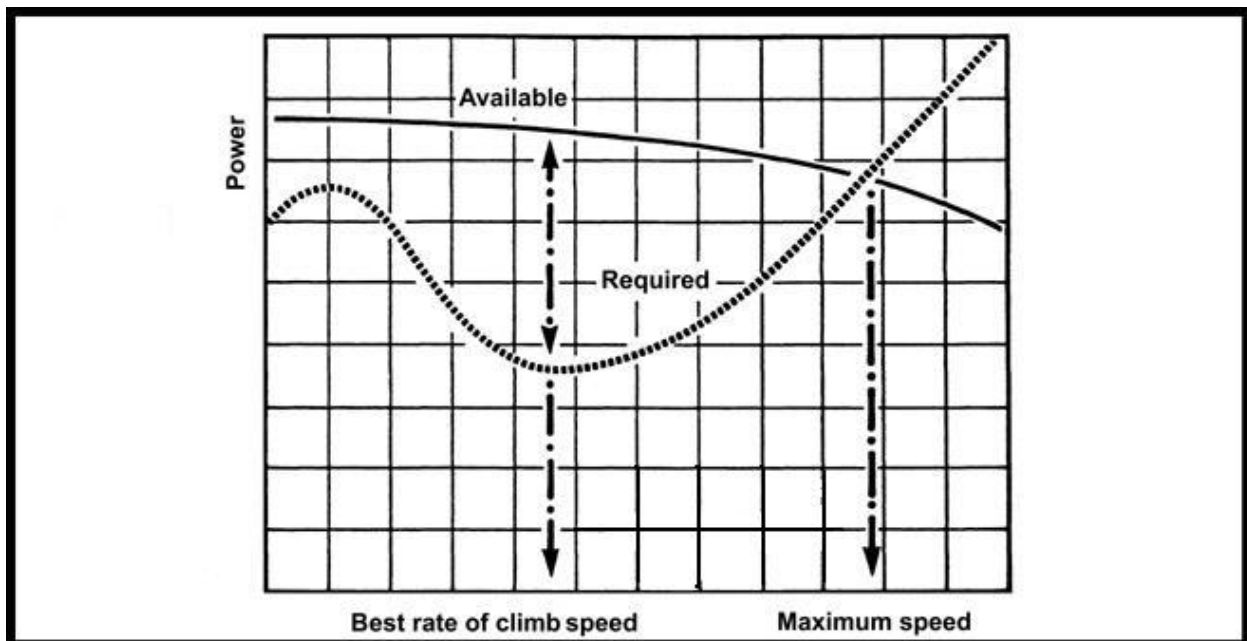

Figure 5-1: Power Required/Available Curves

Prior to entering the climb, good airmanship dictates that you ensure that there is no traffic ahead and above. Remember that it may be difficult for an aircraft above to see you.

To enter a climb from cruise flight;

1. ease back on the cyclic to select the attitude for the recommended climb speed;
2. increase collective to the desired power setting. This action tends to cause the nose to pitch up;
3. prevent yaw with pedals throughout; and
4. adjust the airspeed as necessary with cyclic.

While in the climb monitor the engine temperatures and pressures, and maintain a constant lookout for other aircraft.

To level off from the climb:

1. anticipate the desired altitude by 10% of the rate of climb;
2. select the attitude for cruise flight by applying forward cyclic;
3. allow the airspeed to increase;
4. as the speed approaches that desired, reduce power to cruise setting;
5. prevent yaw with the pedals throughout; and
6. adjust the cyclic to maintain the desired cruise speed.

DESCENTS

Descents are commenced with a reduction in power.

Before commencing a descent it is important to conduct a good lookout to ensure that the area ahead and below is clear of other traffic as your forward visibility will be somewhat reduced in the descending attitude.

To proceed from cruise flight to a descent:

1. lower the collective to the desired power setting and prevent yaw through the use of pedals;
2. select the attitude that will give you the desired descent speed, by easing back the cyclic; and
3. as the helicopter begins to descend, adjust the cyclic to maintain the desired speed.

While in the descent, remember to scan your engine instruments to ensure that all temperatures and pressures are within limits, and keep a good lookout for other aircraft.

To level off from the descent to cruise flight:

1. anticipate the desired altitude by 10% of the rate of descent;
2. raise the collective to the cruise power setting and prevent yaw through the use of pedals;
3. select the attitude for cruise flight with cyclic; and
4. adjust the cyclic to maintain cruise speed.

It may also be necessary at times to enter a climb directly from a descent. In many light helicopters the airspeeds for both manoeuvres will be similar and therefore the attitude change, if any, will be small. Prior to proceeding from a descent to a climb, once again ensure that the area ahead and above is clear of other aircraft. When your lookout has confirmed that the area is clear:

1. smoothly raise the collective to the climb power setting, prevent yaw with pedals; and
2. select the desired climb speed or maintain the airspeed with cyclic.

An easy guide to remember the climb and level from the climb is:

A. - Attitude - cyclic
P. - Power - collective
T. - Trim - adjust controls for balanced flight.

An easy guide to remember the descent and level from the descent is:

P. - Power – collective
A.- Attitude – cyclic
T.- Trim - adjust controls for balanced flight.

EXERCISE 6 - TURNS

The turn is a basic manoeuvre used to change the heading of a helicopter. An accurate level turn may be described as a change of direction, maintaining a desired angle of bank, altitude and airspeed with no slip or skid. This is also the description of a co-ordinated turn.

To turn the helicopter, co-ordinate the cyclic, pedals and collective until a desired bank attitude is attained. The object of applying bank during a turn is to incline the lift so that, in addition to supporting the helicopter, it can provide the necessary centripetal force towards the centre of the turn to oppose centrifugal force, which is endeavouring to pull the helicopter away from the centre of the turn.

In a level turn, lift must be sufficient both to support the helicopter and to provide the inward force. Therefore, it must be greater than during straight and level flight. This additional lift can be acquired by increasing power or by sacrificing some airspeed to maintain your altitude.

For training purposes, turns are divided into three classes:

1. gentle turns, involving angles of bank up to 15 degrees;
2. medium turns, involving angles of bank from 15 to 30 degrees; and
3. steep turns, involving angles of bank over 30 degrees.

In addition to level turns there are:

1. climbing turns - normally, climbing turns are gentle turns; and
2. descending turns - descending turns may be gentle, medium, or steep.

Here are some basic facts you should understand:

1. at a given airspeed, the greater the angle of bank;
 - a) the greater the rate of turn;
 - b) the smaller the radius of turn; and
 - c) the greater the load factor.
2. the higher the airspeed at a given angle of bank:
 - a) the lower the rate of turn; and
 - b) the larger the radius of turn.
3. to achieve a turn of the smallest radius and greatest rate for a given angle of bank, fly at the lowest possible airspeed commensurate with safety.

LOAD FACTOR

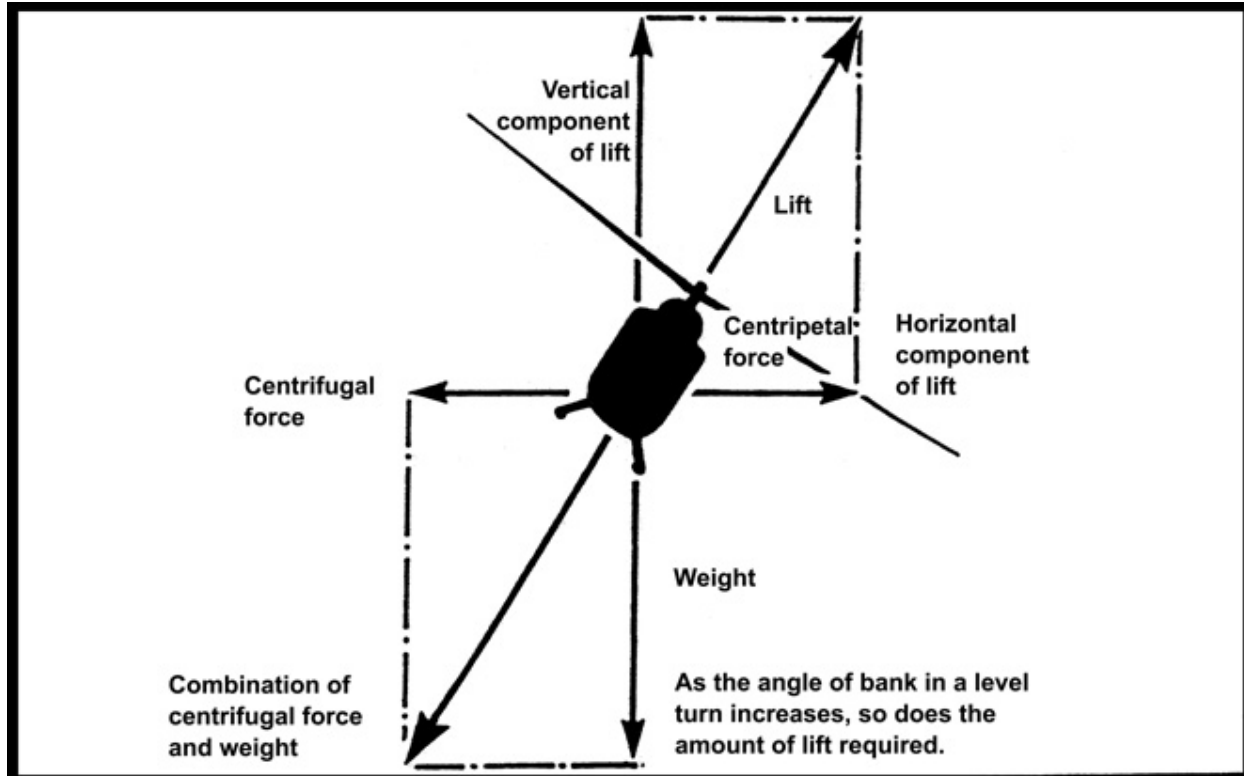

Figure 6-1: Load Factor in a turn

The resultant of weight and centrifugal force during turns produces an increased load factor on the helicopter. See Figure 6-1. Load factor may be described as the total load imposed on the helicopter, divided by the weight of the helicopter, and is expressed in G units. Load factor during a turn will vary with the angle of bank. Airspeed during the turn does not affect load factor, because for a given bank angle the rate of turn decreases with increased airspeed, resulting in no change of centrifugal force. Note that for a 60 degrees bank turn, the load factor for any helicopter is 2 G regardless of its airspeed (Figure 6-2 refers). This means that a 3000 lb helicopter in a 60 degrees bank turn will, in effect, exert 6000 lbs of force on the helicopter structure. Bank angles of up to 30 degrees will produce only moderate increases in load factor that are acceptable under most flight conditions that you will encounter. The load factor rises at an increasing rate at bank angles over 30 degrees, and may produce unacceptable disk load depending upon the helicopter gross weight and the prevailing flight conditions.

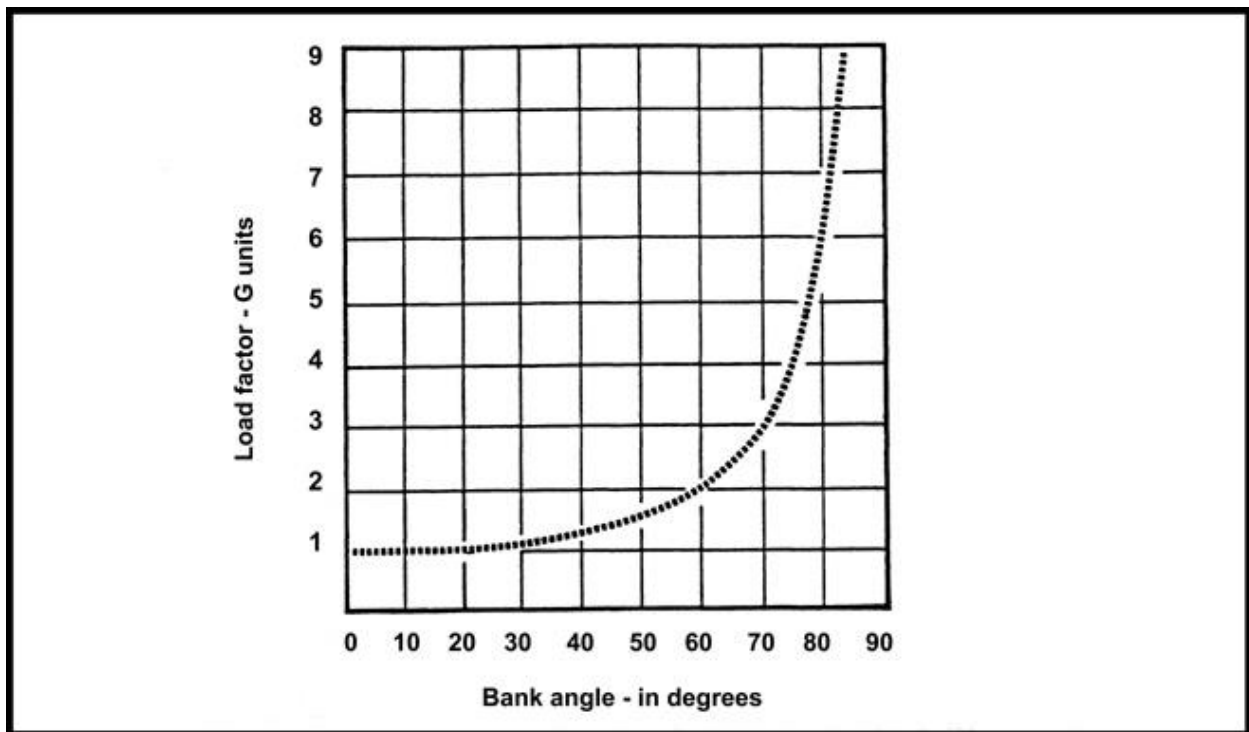

Figure 6-2: Load factors produced at varying angles of bank

In turbulent air, severe vertical gusts can cause a sudden increase in angle of attack, resulting in increased rotor blade loads that are resisted by the inertia of the helicopter. All helicopters have a maximum permissible load limit that must not be exceeded. As a responsible pilot you should be aware of the limitations of your particular helicopter, and avoid situations that may cause the load factor to approach the maximum. Practically what this means is to avoid doing turns over 30 degrees when you are heavily loaded, especially in gusty or turbulent winds.

The importance of look out, searching the sky for other aircraft before and during a turn, cannot be over-emphasized. Before entering a turn, look around carefully in both directions, above and below. A casual glance is not good enough. During the turn continue to look out especially in the direction of the turn. When recovering from the turn, look around again, in both directions, above and below. To maintain a good lookout, and manage the helicopter at the same time requires the pilot's constant attention.

Posture is important in all helicopter manoeuvres, and especially so in turns. Sit comfortably upright, do not lean away from the centre of the turn, nor should you make a conscious effort to keep your body stiffly vertical. Relax and ride with the turn. Stiffening up or continually changing sitting position affects visual references, and may cause handling of the controls to become tense and erratic.

An accurate level turn entry requires that the helicopter be flying straight and level as accurately as possible, prior to entering the turn. Any error made before entering the turn is likely to be exaggerated as the turn develops. The same principle applies to turns while descending or climbing.

In making an accurate turn, the trained pilot co-ordinates the movement of all three controls so that the entry, the sustained turn, and recovery is made in one apparently simultaneous movement. Cyclic controls bank and pitch attitude, the collective controls altitude and the pedals prevent yaw.

To execute a turn from straight and level flight:

1. make sure the helicopter is in accurate straight and level flight;
2. look out for other aircraft;
3. roll the helicopter gently to the desired bank attitude with lateral cyclic, maintain this attitude, and at the same time;
4. use appropriate pedal pressure to control any tendency for the helicopter to yaw;
5. use cyclic to maintain the correct attitude in relation to the horizon; and
6. maintain the lookout.

In a gentle turn, the position of the nose in relation to the horizon, which is the visual reference for pitch attitude, will remain relatively the same as in straight and level flight. However, as the angle of bank is increased, the attitude of the disc must be altered by backward pressure on the cyclic. This is to compensate for the added load factor imposed by centrifugal force as the turn steepens. The loss in airspeed, or the need for an increase in collective to maintain airspeed, becomes more apparent as the angle of bank increases.

As the helicopter settles into an accurate turn in co-ordinated flight:

1. the nose will move steadily around the horizon, neither rising nor falling;
2. the airspeed will be constant;
3. the turn indicator will show a constant rate of turn;
4. the ball will be centred in its glass tube;
5. the altimeter will be steady, and
6. you should repeatedly check the attitude instruments and maintain a good lookout.

One common fault when entering turns is excessive use of the pedals. This fault can be corrected quickly or completely prevented, if you remember right from the outset not to apply pedal unless it is necessary to control yaw. Normally you may need only a small pedal input into the turn.

To recover from a turn onto a pre-selected heading:

1. look out for other aircraft;
2. anticipate the desired heading by approximately 10 degrees;
3. roll the helicopter to level flight with lateral cyclic, and at the same time;
4. use appropriate pedal pressure to control yaw;
5. select correct attitude with cyclic; and
6. maintain the new heading and look out.

Climbing and descending turns are executed like level turns except that instead of maintaining a constant altitude, a constant climb or descent is maintained. The control inputs to enter, maintain, and recover from the turn are the basically the same as in level turns. Initially, climbing and descending turns will be entered from normal straight climbs and descents and the recovery made back to straight climbing or descending flight, to enable you to experience and readily observe the difference in pitch attitude necessary to maintain the desired airspeed. As you gain proficiency, these turns will be entered directly from straight and level flight, and recovery made directly back to straight and level flight.

STANDARD RATE TURNS

The standard rate turn is a turn at the rate of 3 degrees per second. The rate at which a helicopter turns is determined by airspeed and angle of bank. At a given airspeed a specific angle of bank will provide a certain rate of turn. A simple way to estimate the angle of bank required for a standard rate turn at a given airspeed is to take 10% of the airspeed (mph) and add 5 to the quotient or add 7 to the quotient if the airspeed is in nautical miles (kt). For example, at 100 mph, $(10 + 5) = 15$ degrees of bank; at 80 kt, $(8+7)= 15$ degrees of bank.

During a turn, instrument indications are as follows:

TURN AND BANK INDICATOR. The needle will deflect in the direction of the turn and will indicate the rate at which the helicopter is turning. In a co-ordinated turn the ball will be centred in its curved glass tube. If the ball is off-centre to the inside of the turn, the helicopter is slipping into the centre of the turn. If the ball is off-centre to the outside of the turn, the helicopter is skidding out from the turn.

ATTITUDE INDICATOR. The horizon bar will remain parallel to the real horizon, and the miniature aircraft in relation to the horizon bar will bank in the same direction as the helicopter. This instrument indicates the angle of bank and the attitude of the helicopter in the pitching plane. The nose of the miniature aircraft in relation to its artificial horizon corresponds to the pitch attitude of the nose of the helicopter in relation to the real horizon.

HEADING INDICATOR. Immediately as a turn begins, this instrument begins rotating to indicate the successive new headings of the helicopter during the turn. When the turn stops, it stops. To decrease the numerical values on the face of the instrument turn left; to increase values turn right. A memory aid is "left for less".

AIRSPEED INDICATOR. The instrument that does not perceptibly react until well into a co-ordinated turn is the airspeed indicator. Since the load factor increases as a result of the turn, additional lift must be obtained by tilting the rotor to the rear. In a gentle turn the decrease is barely noticeable, even in a well-executed medium turn the airspeed may be only slightly lower. If the nose is allowed to pitch up too high there will be a decrease in airspeed; conversely, if the nose is allowed to pitch down too low, the airspeed indicator will rapidly indicate an increase in speed.

ALTIMETER. In a co-ordinated level turn, the altimeter needle would remain stationary at the selected altitude. If the nose is held too high, there will be an increase in altitude. If the nose is allowed to drop too low, a decrease in altitude will be indicated.

EXERCISE 7 - AUTOROTATIONS 1 (UPPER AIR)

An autorotation may be defined as the condition of flight where the rotor is driven by aerodynamic forces, with no power being delivered by the engine. Autorotational flight is a basic and essential emergency procedure at which every helicopter pilot must be proficient. Although modern helicopter engines and other major components are extremely reliable, pilots will ensure that they are capable of flying the helicopter under other than normal situations, including engine failure. During autorotation the helicopter is still flying despite the fact that the engine is not delivering motive power to the rotors. It remains fully manoeuvrable albeit in descending flight. Remember also that the airflow is now upward through the disc rather than downward as in powered flight. Prior to conducting this exercise, your instructor will review with you the manufacturer's recommended airspeeds and rotor RPM for minimum rate of descent in autorotation. These speeds can be found in the aircraft flight manual.

This exercise will be your introduction to autorotations. In it you will be concentrating on the entry procedure, establishing a descent at the airspeed for the minimum rate of descent, and how to conduct an overshoot to the climb from the autorotational descent.

CHECKS

Good airmanship requires that, prior to carrying out autorotational descents, you must perform "pre-entry" checks, to include:

1. **pre-landing check.** It is important to ensure that all engine instrument indications are normal since you will be retarding the throttle to idle. Check you are still strapped in and there are no loose articles in the cabin;
2. **look out.** Confirm that the immediate vicinity is clear of other aircraft and pay particular attention to your descent path ahead and below;
3. **select a suitable precautionary landing area.** In the event that you are unable to re-engage the engine a landing would become necessary; and
4. **verbal warning.** A warning of your intentions to the crew, in this case, your instructor, should preface all practice autorotations. The phrase "Practice engine failure" clearly describes the manoeuvre that you are about to conduct.

A memory aid for the checks is as follows:

H - Height - sufficient for exercise;

A - Area - good for landing if required;

S - Security - straps, no loose articles;

E - Engine - Temperatures and pressures; and

L - Lookout - Good look around especially below and check the wind velocity.

Once you have completed the pre-entry checks, you may now set up the helicopter for the entry to autorotation. Select an altitude that will provide sufficient height so that you will not be rushed, and that will give you plenty of time to experience the flying characteristics of the helicopter in autorotation. For the purpose of this exercise, establish the helicopter straight and level prior to the point where you will lower the collective; the airspeed should be at normal cruise. While it is not always possible to perform this manoeuvre into wind, during the early stages of autorotational training you should ensure that you are flying into the wind, and, of course, that the area below is clear.

NOTE: *The policy of most schools is that they do **NOT** let students perform any autorotational exercise when solo.*

ENTRY

To enter autorotational descent first lower the collective fully; to ensure that the rotor RPM does not exceed the manufacturers' limits; smoothly roll off the throttle. It is important to make these movements smooth, so that you can anticipate the requirement for aft cyclic to prevent any nose down pitching moment, and at the same time, for a pedal adjustment to keep straight. The rotor RPM and engine RPM needles should be split at this point.

The helicopter will now begin to descend. Select an attitude with cyclic to decrease the airspeed from cruise to the manufacturer's minimum rate of descent speed. You will see that just as in powered flight, the cyclic controls the heading and the airspeed. The collective controls rotor RPM in autorotation, raise it to reduce RRPM, lower it to increase RRPM. You must also maintain the helicopter in coordinated flight with the pedals. Flying with the ball out of centre is aerodynamically inefficient and will adversely affect the airspeed and the glide distance.

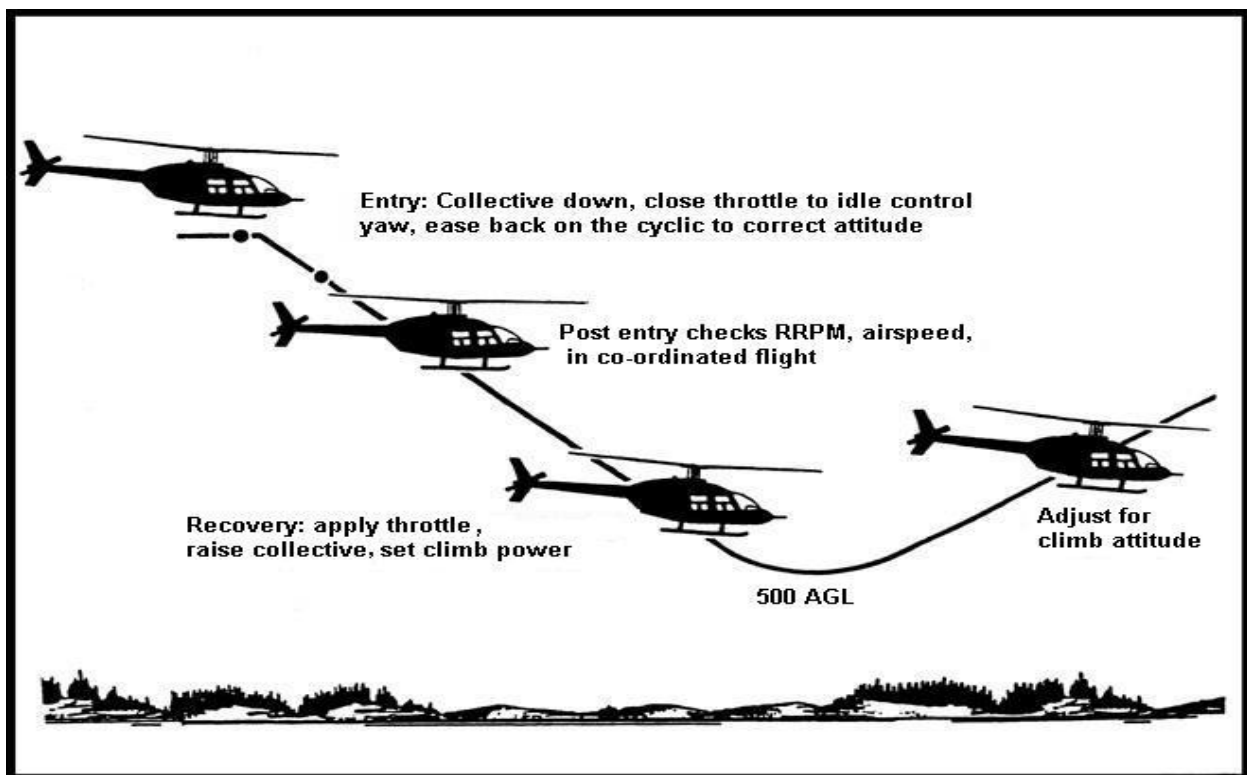

Figure 7-1: Autorotation Entry To Overshoot

TURNING

Your instructor will have you carry out some turning manoeuvres. Particularly note that both the RRPM and the rate of descent increase, and that it may be necessary to raise the collective slightly to prevent a possible rotor overspeed. Later on you will learn how to use these two facts to vary your range in autorotations depending on the existing conditions. In any case you will want to roll off any bank, as soon as practical, to reduce the rate of descent and to prepare for the flare and landing. However, in this exercise you will be practising the overshoot while later lessons will deal with the autorotative flare and landing. During the descent you must check the temperatures and pressures are in the normal operating range and that the engine is still operating and will be available for you to commence your overshoot.

OVERSHOOTING

To make an overshoot from the autorotational descent, smoothly increase the throttle to rejoin the needles within the correct operating range. Be prepared to raise the collective as necessary to prevent any tendency for the rotor to overspeed. Once the needles are matched, raise the collective to set climb power and at the same time adjust the cyclic to achieve the best rate of climb. Anticipate the requirement for pedal to maintain the helicopter in co-ordinated flight throughout the transition from autorotational descent to powered flight. Once you have established a stabilized climb perform a post-takeoff check, ensuring all temperatures and pressures are in the normal operating range. This is important because you have been operating the engine at idle while conducting your autorotations.

Your instructor will demonstrate straight-ahead and turning autorotations. You will have the opportunity to practise entries, descents, and overshoots for these types of autorotations. While it is important to react quickly in the event of an engine failure, or other emergency requiring an autorotation, at this stage of your training the emphasis should be on smoothness and accuracy.

EXERCISE 8 - HOVERING

While carrying out previous exercises, you have undoubtedly observed your instructor perform various hovering manoeuvres. Prior to starting this exercise your instructor will review the following ground school points:

1. ground effect (Fig 8-1); and
2. flight manual performance charts for in-ground effect and out-of-ground effect hover.

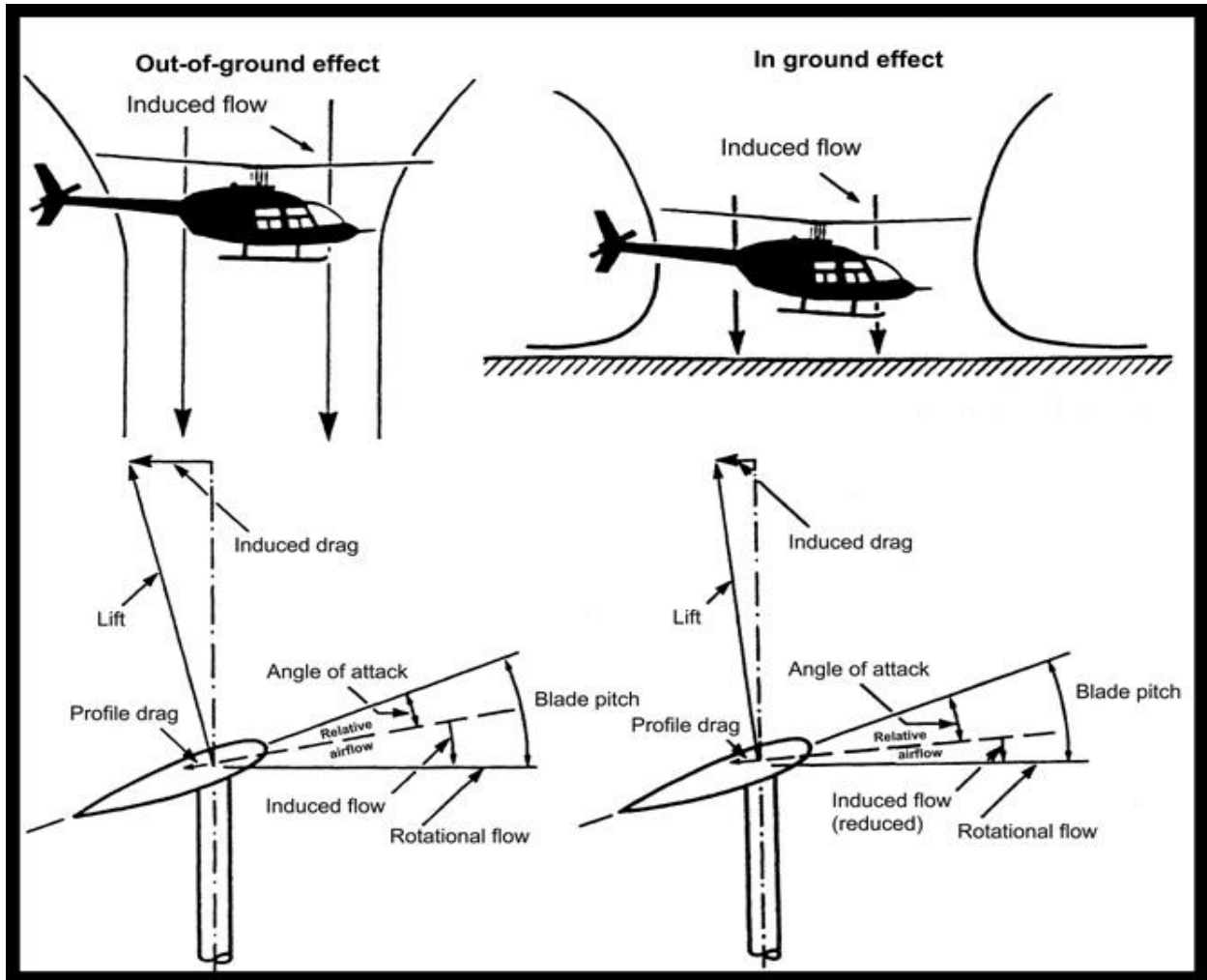

Figure 8-1: Ground Effect

You may remember from ground school that the helicopter requires considerable power to hover. Therefore, it is important that you ensure that there is sufficient power available and that you monitor engine temperatures and pressure throughout all hovering manoeuvres.

The importance of lookout has been stressed in previous exercises. Lookout is extremely important when hovering. You will be flying near the ground so you must keep a sharp lookout to avoid accidentally flying into any obstacles.

A large, flat, open field, free of obstacles, should be selected for all hovering practice. Ensure that the surface is firm, and there is no loose material such as sand, snow, cut grass, or leaves, which the rotor wash may blow up and which might be ingested by the engine.

Light single-engine helicopters generally hover with the skids 3 to 5 feet above ground. This height will ensure that the skids are well clear of the ground and any low obstacles, and will also allow you to land safely should you ever have an engine failure. Take note that a normal hover at 3 to 5 feet will require less power than a hover at 10 feet.

EFFECTS OF CONTROLS

Hovering is defined as maintaining a constant height and heading over a given position on the ground. In a previous lesson you learned the effects of controls in cruise flight. These effects are very similar in the hover.

THE CYCLIC

In a hover, the cyclic is used to maintain a fixed position over a spot on the ground. As a recall, the cyclic controls disc attitude. A change of disc attitude will be followed by a change in fuselage attitude and, in hovering flight; this will cause the helicopter to move horizontally across the ground. For example, moving the cyclic forward or aft will cause the nose to drop or rise and the helicopter will move forward or backward. Similarly, moving the control to the left or right will cause the helicopter to move over the ground to the left or right.

In most types of helicopters there is a slight time lag between cyclic movement and aircraft response.

To cease horizontal motion and to regain a steady hover requires two cyclic movements; one to stop the movement, and a second to stabilize the helicopter in the hovering attitude. For example, if you note the helicopter is moving rearward the following cyclic movements will be required; the cyclic would be moved very slightly forward to stop the rearward movement, and then centralized in a position that maintains the helicopter in a steady hover.

The cyclic in the hover is more sensitive than in forward flight. A very small cyclic control movement will result in a very large helicopter movement. Your instructor will demonstrate this sensitivity of the cyclic in hovering flight.

North American helicopters usually hover with a left skid low attitude. This is caused by Tail Rotor Roll, which will be reviewed by your instructor (Fig 8-2).

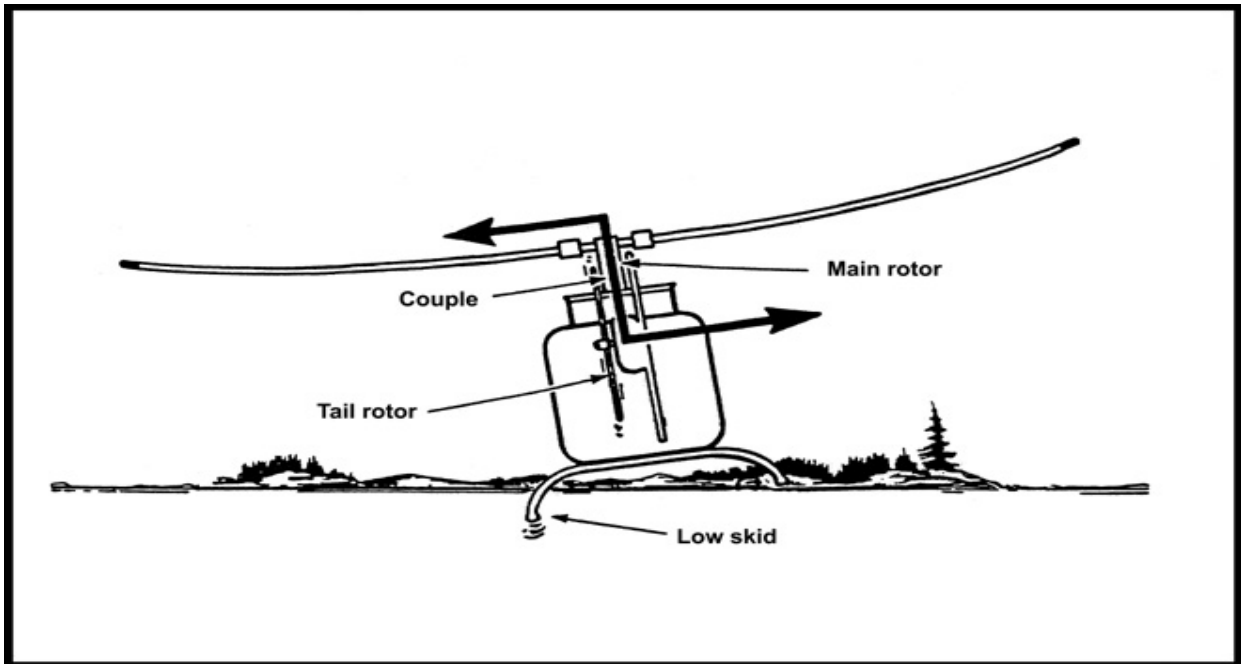

Figure 8-2: Tail Rotor Roll

THE COLLECTIVE

In the hover the collective is used in the same manner as in forward flight. The collective controls the height of the hovering helicopter above the ground. Raising the collective will result in an increase in helicopter hover height and a decrease in hover height will result if the collective is lowered.

Secondary effects of controls will also be noticed in the hover. Raising the collective will result in an increase in torque and this will cause the helicopter to yaw to the right. A yaw in the opposite direction will occur if the collective is lowered. In addition, if you are flying some piston engine helicopters, the throttle may have to be adjusted to maintain RPM as the collective is raised or lowered.

THE PEDALS

During hovering flight the anti-torque pedals are used to maintain or change the helicopter heading. In the hover, the effect of torque is more noticeable than in forward flight. Therefore, the nose of the helicopter will tend to yaw more in the hover, and this has to be countered with opposite pedal pressure. To turn left in the hover, left pedal is applied, and the reverse is true for a right turn.

NOTE: *In a piston engine helicopter, the throttle may have to be increased slightly as left pedal is applied, and decreased as right pedal is applied.*

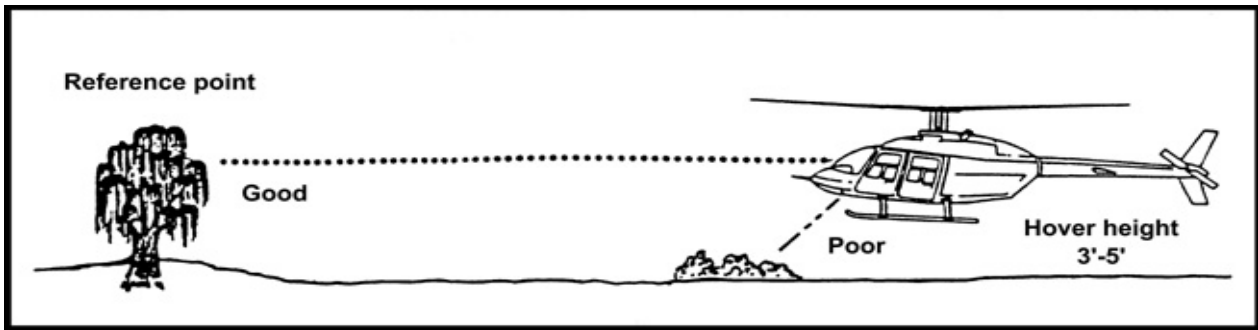

Figure 8-3 Hover reference points

VISUAL CUES

In a hover any change in attitude, if not corrected, will cause the helicopter to move. You must recognize any changes in attitude and make the necessary control corrections before the helicopter moves. Initially, it may be difficult to recognize these changes. As in upper air flying, it may be easier to first use the horizon as a reference, and then as you become more proficient focus your eyes on a reference closer to the helicopter (approximately 50 feet).

SUMMARY

The cyclic is used to control the disc attitude, and therefore the helicopter position over the ground. Height is controlled with collective, and the pedals are used to maintain directional control. In a piston-engine helicopter, the throttle may have to be adjusted as pedals or collective are moved.

NOTE: *The secret to mastering the skill of hovering a helicopter is to use very small, smooth control movements and lots of practice.*

EXERCISE 9 - TAKEOFF AND LANDING

In this exercise you will learn how to take off to and land from the hover. It is important for reasons of safety of flight that you should be able to perform this manoeuvre accurately, as any lateral drift could cause a rolling moment if ground contact is made, possibly leading to dynamic rollover. Similarly rearward movement is undesirable, as you cannot see behind you and the tail rotor could be severely damaged should contact be made with an obstacle.

Before takeoff, the pre-take-off check should be completed, and you must look out to check the surroundings.

After every takeoff, a hover check must be completed.

Prior to landing, the area must be checked to ensure it is free of obstacles and the landing surface is suitable.

If possible make your takeoffs and landings into wind.

TAKEOFF TO THE HOVER

The first step prior to take off is to complete the pre-take off checklist. This includes a lookout to ensure the area is clear.

The effects of controls for takeoff and landing are the same as for hovering. They are used as follows:

1. The cyclic is used to maintain position over the ground during the takeoff. Before starting the takeoff, the cyclic is centralized, and then adjusted as required to ascend vertically and prevent the helicopter from drifting. Cyclic position during takeoff will vary with aircraft type, wind direction, and weight and balance. For accurate control it is important that the cyclic inputs be very smooth and small.
2. The collective is used to lift off and climb from the ground to the normal hover height of 3 to 5 feet. The collective should be raised slowly so the other controls can be adjusted, as the helicopter becomes "light on the skids"; this will ensure that an accurate takeoff is accomplished. The right skid will leave the ground first, so you will have to ease the cyclic to the right to compensate for this.
3. For takeoff, the pedals are used to control the heading of the helicopter. Prior to take off the pedals are centralized. As torque is increased pedal will have to be applied to maintain heading. The amount of pedal required will vary with the wind direction and power.
4. Throttle may have to be adjusted in some piston engine helicopter to maintain RPM throughout the takeoff.

It is important that your eyes be focussed outside on normal hover references. Glance quickly in at the console to monitor engine instruments.

HOVER CHECK

Immediately after the aircraft is in the low hover (approximately 6 inches) a “hover check” is completed, then proceed to normal hover height. The check may vary with helicopter type, but must include the following items:

1. ensure the centre of gravity is in limits, by observing cyclic stick position;
2. note the power required to hover, and the power available for flight; and
3. check that control response is normal.

THE LANDING

A normal landing is initiated from a 3 to 5 foot hover with the helicopter facing into the wind if possible.

The controls are used as follows:

1. cyclic to maintain position over the ground;
2. collective to control rate of descent; and
3. pedals to control helicopter heading.

It is important that you start the landing from a stable hover. From the hover, start a slow rate of descent with collective. As the helicopter approaches the ground, you will have to lower the collective slightly more to compensate for increased ground effect. Throughout the descent, heading and hover position are maintained with pedals and cyclic. For safety reasons, it is important that the helicopter does not touch down with sideward or rearward drift to avoid dynamic rollover. As the helicopter skids touch the ground, continue to slowly lower the collective to flat pitch, and then centralize the cyclic and pedals. Remember that the left skid will touch the ground first for North American produced helicopters and vice versa for French helicopters.

If you have problems maintaining control during the landing, smoothly climb back to a normal hover, then stabilize the hover prior to initiating another landing.

EXERCISE 10 - HOVERING EXERCISES

In this exercise you will learn how to perform the following manoeuvres:

1. turns at the hover; and
2. hover-taxiing.

Manoeuvring close to the ground is very much part of the helicopter environment and you will find that these manoeuvres are carried out as a matter of course.

During the exercise, bear in mind the following airmanship points to include that you:

1. ensure the manoeuvring area is flat and free of any obstacles that could present a hazard to the tail rotor;
2. monitor the engine instruments to ensure that no limitations are exceeded; and
3. anticipate the effect of wind.

PEDAL TURNS AT THE HOVER (TURNS AROUND THE MAST)

Begin your pedal turns from a stable hover, preferably with the helicopter facing into wind. Look out to ensure the surrounding area through which the tail rotor will pass is clear of obstacles that could present a hazard. Start the turn by applying pedal to rotate the helicopter in the desired direction: to turn left apply left pedal, to turn right apply right pedal. Control the rate of the turn with pedal; that is: less left pedal to reduce the rate of a left turn, and vice versa. The amount of pedal required will vary with the strength of the wind. To stop the turn, apply opposite pedal, and then stabilize using pedals as required maintaining the heading. In strong winds weathercocking will cause the rate of turn to increase as the nose passes 180 degrees to the wind. Throughout the turn the cyclic is used to maintain position over the ground as you learned in previous hovering exercises. If there is a wind, the helicopter will tend to drift downwind; therefore you will have to displace the cyclic into the wind to counter this tendency during the turn. The stronger the wind the more cyclic is required.

Collective is used to maintain height in the turn. In strong winds, more frequent power's changes will be required to maintain height.

In some piston engine helicopters the throttle may have to be adjusted to maintain the correct operating RPM as you manipulate the pedals and collective during the turn.

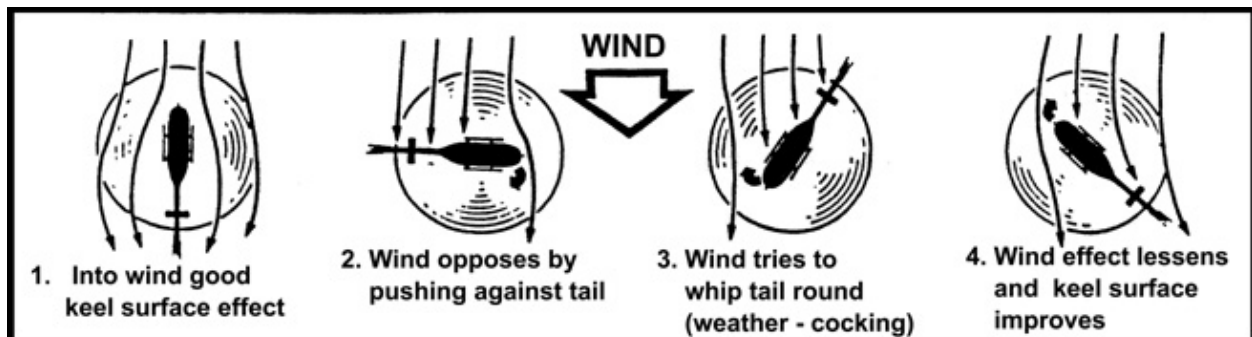

Figure 10-1: 360° degree Hovering Turn

It is important that you anticipate the effect of the wind, as the helicopter will tend to align itself with the wind direction. This “weather-cocking” effect is caused by the wind pushing against the vertical fin and body in the same fashion as a weather vane. This will cause a variation in the amount of pedal required as the turn progresses through a full circle, and is most noticeable when the helicopter is at 90 degrees to the wind direction (Fig 10-1).

The continuous use of high power in this exercise means that a careful watch should be kept on the engine temperatures and pressures. Prolonged hovering out of wind, specifically downwind should be avoided because of carbon monoxide poisoning. Check the helicopter flight manual for any such limitations.

In strong gusty wind conditions a turn away from the into-wind position should be opposite to torque reaction, i.e.: to the left in a North American helicopter. In this way you will ensure that there is sufficient tail rotor control available. Should control limits be reached at this stage, a safe turn back into wind can be accomplished.

HOVER-TAXIING

Light single engine helicopters are hover-taxied at the normal hover height of 3 to 5 feet skid height. For safety considerations it is desirable to hover-taxi at a slow speed; approximately a normal walking pace. This is important as:

1. a walking pace will allow the pilot to maintain precise control and will avoid operating the helicopter near translation; and
2. the helicopter attitude will be horizontal, or nearly so. Therefore in the event of an engine failure no attitude change will be required for a safe touchdown.

To begin taxiing ease the cyclic slightly forward, and as the helicopter begins to move, adjust the cyclic to maintain a walking pace. The pedals are used to maintain an accurate heading. In crosswind conditions, a combination of pedals and cyclic will be required to keep the helicopter moving in a straight line across the ground (Fig 10-2). The skids should be tracking parallel to the direction of movement. Collective is used to maintain a constant height throughout the manoeuvre. When taxiing downwind, it is important that you control the ground speed to maintain the walking pace.

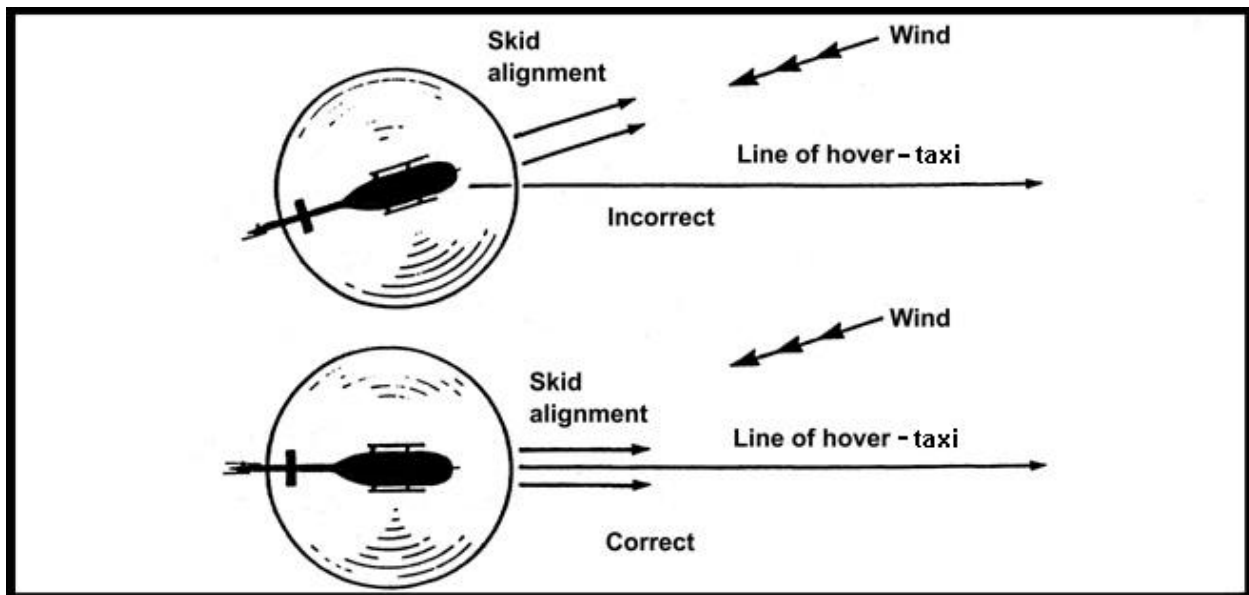

Figure 10-2: Fuselage alignment with direction of hover-taxi

To stop forward movement, ease the cyclic slightly aft. It will be necessary to anticipate where you wish to stop because of the lag between cyclic input and helicopter response. This is due to the inertia of the helicopter itself. Make the required cyclic movement small; there is no need to flare the helicopter.

All cyclic movements should be small and smooth; avoid rapid and excessive aft applications of cyclic to ensure that you do not put the tail rotor in jeopardy.

If you are flying a piston engine helicopter, the throttle may have to be adjusted to maintain the correct RPM as the collective and pedals are manipulated.

EXERCISE 11 - ENGINE FAILURE

ENGINE FAILURE AT THE HOVER/HOVER-TAXI

Although modern helicopter engines are extremely reliable, there is always the possibility of a failure, however remote. As a helicopter pilot, you must train for this possibility, and in this exercise will learn how to deal with an engine failure while operating your helicopter in the hover or the hover-taxi. The operational helicopter pilot spends a considerable amount of his working flying time in the hover environment, performing a variety of tasks, and he must therefore be competent to handle this type of emergency safely and efficiently.

You should not refer to this manoeuvre as an autorotation. When the engine fails at the hover there is insufficient height to successfully enter autorotative flight. Were you to lower the collective lever, the helicopter would sink rapidly to the ground and would likely suffer damage. If the engine should fail in the hover, the rotor does not immediately cease to rotate, but will gradually slow down due to drag. However, it still possesses a considerable amount of energy and inertia at the moment of engine failure that can be used to cushion the helicopter onto the ground.

HOVERING ENGINE FAILURE

In the hover, when an engine failure occurs, the helicopter will instantly yaw to the left as engine torque is removed (counter-clockwise rotating rotor). Apply right pedal immediately to correct yaw. It will also drift to the left as the tail rotor thrust is diminished. You will remember that you compensate for tail rotor thrust in the hover, by holding a small amount of left cyclic, to prevent the helicopter drifting to the right. When the tail rotor thrust is removed then the left cyclic will cause a drift to the left. Should you be hovering into a wind, the helicopter will also tend to drift to the rear as the main rotor thrust is reduced. Lastly, the helicopter begins to sink due to the reduction in lift produced by the main rotor.

The pilot must compensate for the above reactions prior to touchdown, as it is possible for a rollover to occur if drift, or yaw, is present during the landing. Collective should be increased as required to cushion the touchdown.

HOVER-TAXI ENGINE FAILURE

Should an engine failure occur while you are in the hover-taxi, the helicopter reactions will be the same except, of course, for the existing forward speed. It is most important that aft cyclic is not applied in an effort to arrest forward movement, as there is a real danger of striking the tail rotor as the helicopter settles to the ground. Touchdown with some forward speed is quite acceptable, and in most cases the helicopter is run forwards onto the ground.

Your instructor will demonstrate the sequence of events to you and the desired pilot reaction:

1. verbal warning; it is good airmanship to precede the practice emergency with the announcement "practice engine failure";
2. close the throttle;
3. counteract the yaw and any tendency to drift with opposite pedal and cyclic; and
4. as it sinks, cushion the helicopter onto the ground by increasing the collective.

NOTE: *Ensure that the skids are parallel to the direction of travel for the touchdown to avoid the possibility of a rollover.*

5. after touchdown, hold the controls until the helicopter has come to a complete stop, then lower the collective pitch to the full down position and move the cyclic and pedals to the neutral position.

EXERCISE 12 - TRANSITIONS

This exercise is the basis of many others and the skill learned will be used in almost every flight you make from now on in your career. Your instructor will review:

1. flapback;
2. translational lift;
3. dissymmetry of lift; and
4. the height/velocity diagram for your helicopter type.

The manoeuvres that are employed to accelerate the helicopter from the hover to forward flight, and decelerate it from forward flight to the hover, are known as transitions. In fact all accelerations or decelerations of the helicopter in any direction as a result of cyclic change are transitions.

During this exercise, you concentrate on performing smooth and accurate transitions. The ability to perform accurate transitions is important in the working environment of the helicopter pilot.

Remember to carry out a careful lookout during this exercise and to perform a clearing turn prior to each takeoff. Do this by turning 90 degrees right or left and observing that the approach area is clear of other aircraft.

TRANSITION TO THE CLIMB

Begin the transition to the climb from a steady into-wind hover at normal hover height (Fig 12-1):

1. make the clearing turn to ensure that both approach and departure paths are clear;
2. ease the cyclic forward to initiate forward movement, and as you have tilted the disc thereby decreasing the vertical component of lift;
3. increase collective sufficiently to maintain your height and to prevent the helicopter from sinking;
4. apply additional forward cyclic to prevent the occurrence of flapback as a result of lift dissymmetry;
5. as effective translational lift is achieved, the helicopter begins to climb, smoothly apply climb power and set the best rate of climb speed's attitude; and
6. prevent yaw throughout the manoeuvre with pedals.

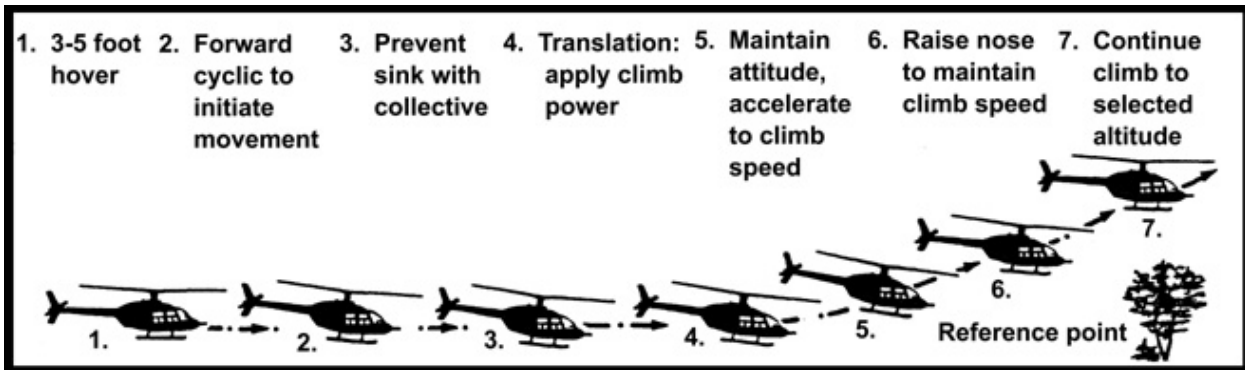

Figure 12-1: Transition to Forward Flight

As effective translational lift is achieved the nose will tend to rise and the helicopter will want to climb. Remember to stay within the take-off corridor of the Height/Velocity diagram. Forward cyclic may be required to prevent the helicopter from climbing into the “Avoid” curve. In winds of approximately 15 mph or more, flapback will not be encountered as the helicopter is already experiencing translational lift (Fig 12-2).

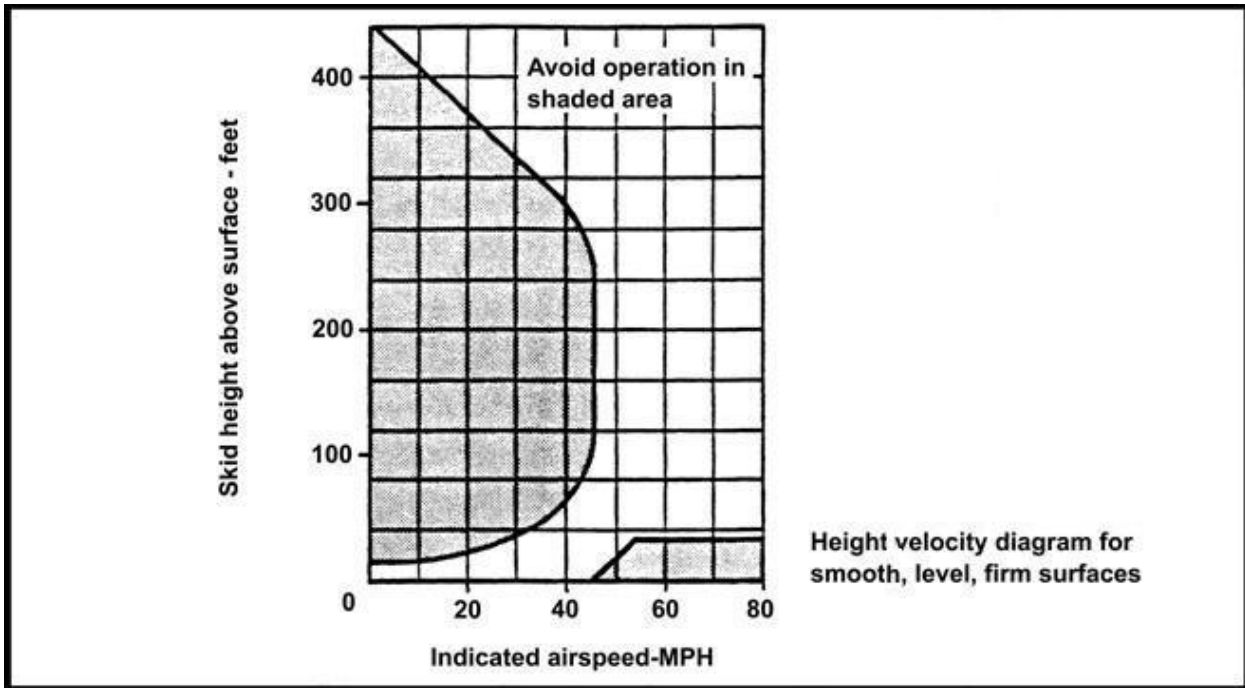

Figure 12-2: Height/Velocity diagram showing “Avoid” areas for a typical light, single-engine helicopter

During this exercise, your instructor will demonstrate the effects of flapback if it is not compensated for with additional forward cyclic during the transition.

TRANSITION FROM STRAIGHT AND LEVEL FLIGHT TO HOVER

This transition is the standard type of approach to a hover or to a landing that will be utilised throughout your training and your career. (Fig 12-3)

The manoeuvre requires that you combine two separate actions in a co-ordinated procedure to achieve:

1. height reduction; and
2. speed reduction.

HEIGHT REDUCTION

The height of the helicopter has to be reduced from the approach altitude, (this may be circuit height, cruise altitude or whatever altitude you are flying at), to hover height above ground. Ideally this is a constant angle, straight-line type of approach, which can be made with little change of attitude and gradual changes in power.

SPEED REDUCTION

The approach speed must be progressively reduced to zero groundspeed as you arrive at the hover. Since different approach angles or wind conditions will cause the airspeed to vary, refer to groundspeed, and not airspeed as indicated on your instruments. A good guide for approaching the touchdown point is to fly so that the helicopter appears to be moving across the ground at a walking pace. If you are able to maintain this visual perspective, your groundspeed will be constantly reducing throughout the transition to the hover.

To begin the transition to the hover, after ensuring the approach path and the landing zone are clear of other traffic, set the helicopter up straight and level, into wind, at a specific height and airspeed. For training purposes a minimum of 300 feet is desirable, with speed appropriate to type:

1. select a suitable approach angle, although it is difficult to visualize initially, an angle of 6 to 8 degrees can be considered a standard approach;
2. initiate the approach by reducing collective, keep straight with pedal, apply aft cyclic to begin a reduction in the airspeed and to maintain a level attitude; the helicopter will begin to descend;
3. use the collective to maintain the desired approach angle. Use the cyclic to maintain the apparent groundspeed at a walking pace;
4. as you approach the ground and speed is reducing through approximately 15 to 20 mph, anticipate the need for an increase in collective as translational lift is lost; this requirement will not be as great if there is a strong wind. As you raise the collective, the nose will pitch up, correct with cyclic;
5. bring the helicopter to the hover over the selected spot, avoid flaring to reduce the groundspeed to zero; if you have been constantly reducing both height and speed during the transition, a flare should not be necessary; and
6. prevent yaw or drift, as you establish your hover, through the use of pedal and cyclic as appropriate.

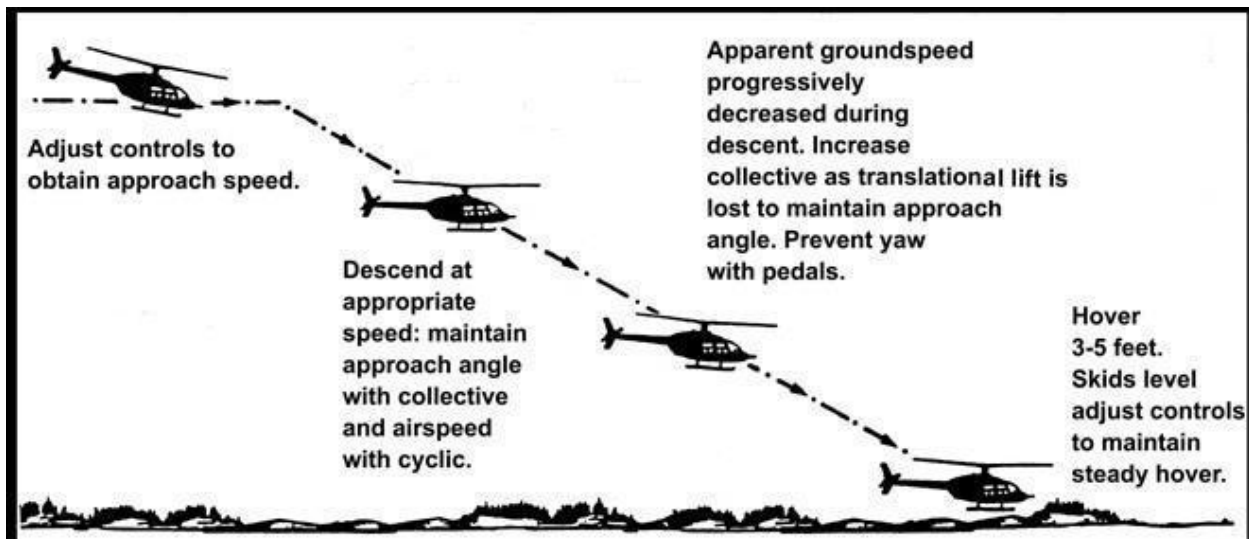

Figure 12-3: Transition to Hover

OVERSHOOTING FROM THE TRANSITION TO THE HOVER

On occasion, it may be necessary to carry out an overshoot from the transition to the hover; this is also a valuable co-ordination exercise. To perform this manoeuvre:

1. after checking the traffic, increase collective to set climb power;
2. at the same time, adjust the attitude to the climb with forward cyclic. Depending on your type of helicopter and its approach speed, there may be no difference between the approach and the climb speeds, and therefore little or no required attitude change; and
3. prevent yaw with pedals.

EXERCISE 13 - AUTOROTATIONS 2 (LANDINGS)

In Exercise 7, you learned how to enter autorotative flight and establish the descent at the minimum rate of descent speed for your helicopter type. You also learned that the helicopter is fully manoeuvrable in autorotation and that turns can be made just as in powered flight. In this exercise, you will learn how to carry out the landing from an autorotational descent in a safe and effective manner.

In addition, you will learn how to perform a “power recovery” in the event that the “full-on” landing may be unsafe due to aircraft performance, inappropriate landing area, a lack of suitable wind or a high-density altitude. The power recovery may be performed to either the hover, or the hover-taxi and is a good coordination exercise and should be practised when it is not possible to perform full-on autorotations. “Power recovery” autorotation is not a substitute for the full-on autorotation. It is essential to practise full-on autorotations to become safe and competent.

In preparation for this exercise, perform the pre-entry H.A.S.E.L. checks that were learned in Exercise 7.

After completing the pre-entry checks, manoeuvre the helicopter to a position, which will allow the safe completion of the full-on autorotation. When in position, smoothly lower the collective and roll the throttle to idle. Adjust the cyclic to acquire the minimum rate of descent speed and remember to compensate both for the yawing and the nose-down pitching moments that occur when the collective and throttle are reduced. During the descent, further adjustment to the cyclic and the collective may be necessary to maintain both the desired speed and the Rotor RPM within limits.

At approximately 50 to 100 feet, depending on the type, a flare is initiated. The purpose of this manoeuvre is threefold: to reduce forward speed, rate of descent, and increase Rotor RPM. Commence the flare by applying aft cyclic, keeping straight with pedals. Your instructor will demonstrate to you the effects of applying too much aft cyclic; this will usually result in a climb. Conversely, little flare will not reduce efficiently the forward speed and the rate of descent. In this case, the landing speed will be much greater than desirable, giving the possibility of damaging the helicopter during a fast ground run or the possibility of the helicopter striking its tail.

The flare should be maintained until the forward speed is reduced to that desired for the landing, and the helicopter’s height has decreased to between 10 and 25 feet, depending on the type. At this point the helicopter is levelled in preparation for the touchdown. Note that it is a level attitude we must achieve, as landing with a nose, or tail-low attitude would cause damage to the helicopter, as a rocking motion will be set up upon touchdown. A nose-low attitude caused by too much forward cyclic will cause the helicopter to accelerate again, resulting in a faster touchdown speed and a longer ground run. Ensure that the skids are aligned with the direction of travel so that you do not land with any lateral motion. In other words, keep it straight with pedal.

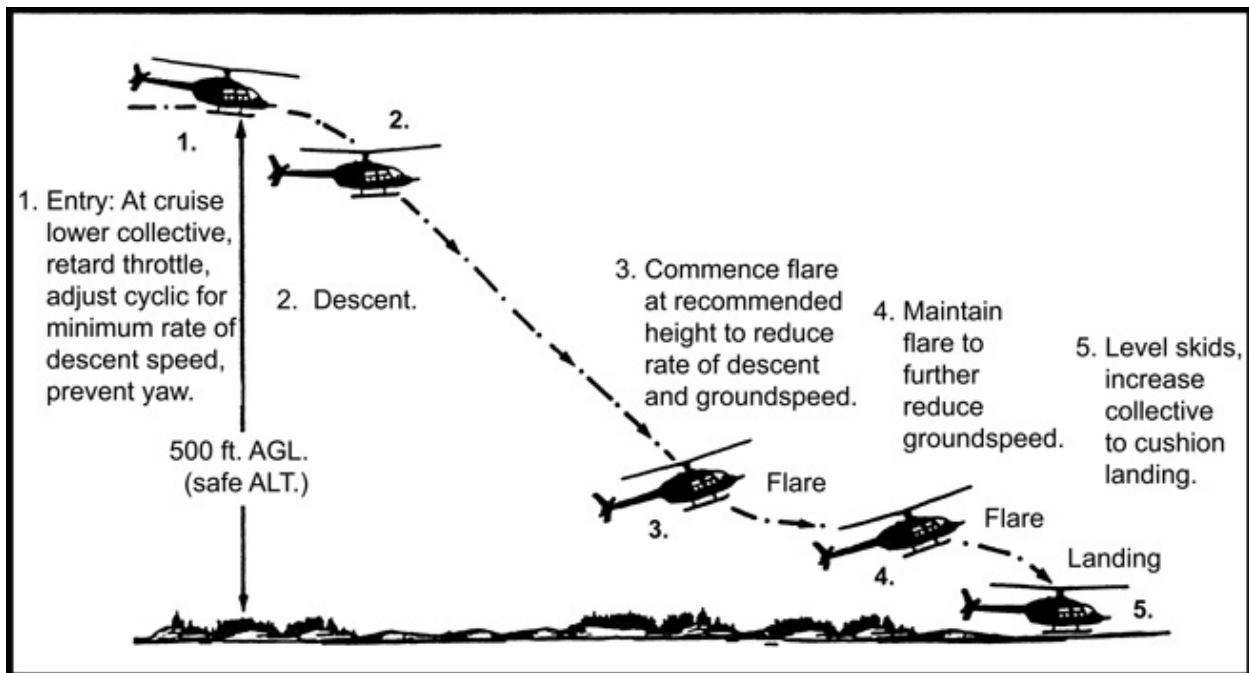

Figure 13-1: The straight-ahead autorotation

The helicopter will now begin to descend vertically. Apply collective pitch as necessary to arrest the descent, and to cushion the helicopter on to the ground. Maintain the heading with pedals, and do not lower the collective until after all forward motion has ceased. You must also maintain the cyclic in a neutral, or slightly forward, position to preclude the development of a rocking motion if running on. Once you have come to a stop, lower collective fully, neutralize the pedals, and carry out a check of the instruments prior to increasing throttle in preparation for the takeoff.

POWER RECOVERY

As previously discussed, there may be occasions when it will not be prudent to conduct full-on autorotations, but you may wish to practice the techniques by performing an autorotational descent to a power recovery.

Enter autorotation as for a full-on, then, at a safe height, increase the throttle to rejoin the needles and bring the RPM into the correct operating range. This increase in power will cause the helicopter to yaw, anticipate this and apply pedal to prevent it. Initiate the flare at the appropriate height just as you did for the full-on autorotation. Maintain the heading with pedals and the flared attitude with cyclic; at the appropriate height, level the helicopter. Collective pitch must now be increased to check any tendency to sink and to achieve a steady hover, or hover-taxi, as the case may be. Throughout the manoeuvre prevent yaw with pedals. You may now carry out a normal transition to a climb. It is important that your throttle and collective movements be smooth and coordinated as it is possible to exceed Engine and/or Rotor limitations during this manoeuvre. Prior to moving on to the next exercise, or manoeuvre, ensure that you complete a check of the engine instruments.

EXERCISE 14 - EMERGENCIES

While modern helicopters are extremely reliable, emergencies requiring prompt pilot action occasionally do occur. Therefore, pilots must have a thorough understanding of the helicopter systems, and must repeatedly practice the handling of in-flight emergencies under simulated conditions, so that they are prepared to successfully handle a real emergency should one occur.

In this air exercise your instructor will acquaint you with the particular emergency procedures as they apply to your type of helicopter. These may include:

1. engine fire during start;
2. engine fire in flight;
3. engine fire during shutdown;
4. hydraulic failure;
5. fuel control or governor failure;
6. engine failure in flight;
7. tail rotor control failure;
8. smoke in the cockpit; and
9. transmission malfunction.

There are also a number of caution advisory lights in most modern helicopters which, when illuminated, give the pilot warning of a malfunction. The pilot's reaction will vary according to the type of helicopter and the particular malfunction, but should generally include a precautionary landing. Indeed it is prudent and shows good airmanship to make a precautionary landing whenever unusual instrument indications are noticed, or when vibrations, noises or control forces that are out of the ordinary occur. Even if the helicopter appears to be operating normally in all other respects, it makes good sense to land and investigate.

Once having made the decision to carry out an emergency or a precautionary landing, these actions should be followed:

1. identify the emergency or malfunction and, where possible, confirm the emergency through other instruments;
2. reduce power and airspeed if appropriate. This will depend on the type of emergency or malfunction that occurs, should it be a transmission chip light, you would not want to reduce power completely, but rather make a power on approach to a landing;
3. select a suitable landing area. In the event of a malfunction, you obviously should not attempt to land the helicopter in an area where obstructions might cause damage. If you did that, you might succeed in making something minor into an emergency of rather larger proportions. On the other hand, an engine fire in flight is of a degree of urgency that would make almost any type of area acceptable;
4. transmit a "PAN" or a "MAYDAY" call as appropriate. Even though you may be out of radio contact, you should transmit this call blind as there is a good chance that a high flying aircraft will hear you. This could considerably reduce the time you spend on the ground should it not be possible to continue your flight; and
5. land. Attempt to make this as normal a landing as possible depending on the urgency of the situation. Land into wind if possible. Avoid the desire to rush the landing procedure.

Throughout your training, you will continue to practise simulated emergencies and malfunctions until your reactions to them become instinctive.

EXERCISE 15 - THE CIRCUIT

This exercise is to learn how to fly an accurate circuit practising all the manoeuvres that you have previously been taught. Your instructor will emphasize the need for precise airspeeds, altitudes, and headings when flying this exercise.

The circuit is of less importance in helicopter operations than in fixed wing flying. Nevertheless, it is valuable training exercise that consolidates all previous air exercises into one convenient package. Through practise of the circuit you will develop accuracy in all aspects of your flying.

Circuit patterns may vary in shape depending on local conditions and training requirements; your instructor will describe, and demonstrate, the one most appropriate to the helicopter type and the school location. The examples described here are referred to as a “racetrack” and a “square” probably the most commonly used helicopter training circuits (Fig 15-1 and 15-2).

Unless noted, Canadian Aviation Regulations require all circuits to be left hand, but often ATC will request a right hand circuit for separation from fixed wing circuits. Since it is likely that you will be flying your circuits in proximity to other aircraft, lookout is very important. Ensure that you perform a clearing turn prior to each transition to forward flight, and that you maintain a good lookout while flying the circuit itself. Although your instructor will emphasize accuracy, do not sacrifice a good lookout because you are concentrating on the instruments in an effort to achieve that accuracy.

Radio communications in the circuit will be performed as per tower instructions or per uncontrolled aerodrome procedures.

FLYING THE CIRCUIT

Choose an area for circuits that allows an into-wind takeoff and an approach path that is clear of obstacles. Before taking off, take note of the following:

1. take-off heading. The reciprocal of this heading will be the downwind heading. Drift corrections will not normally be required if the take-off heading is into the wind;
2. departure references. A readily visible ground reference such as a tree or building in the distance allows you to maintain the desired heading without concentrating on the instruments. Do not over fly buildings even if you use them for a reference; and
3. whether the circuit is to be right or left hand, depending on the circumstances.

RACETRACK PATTERN

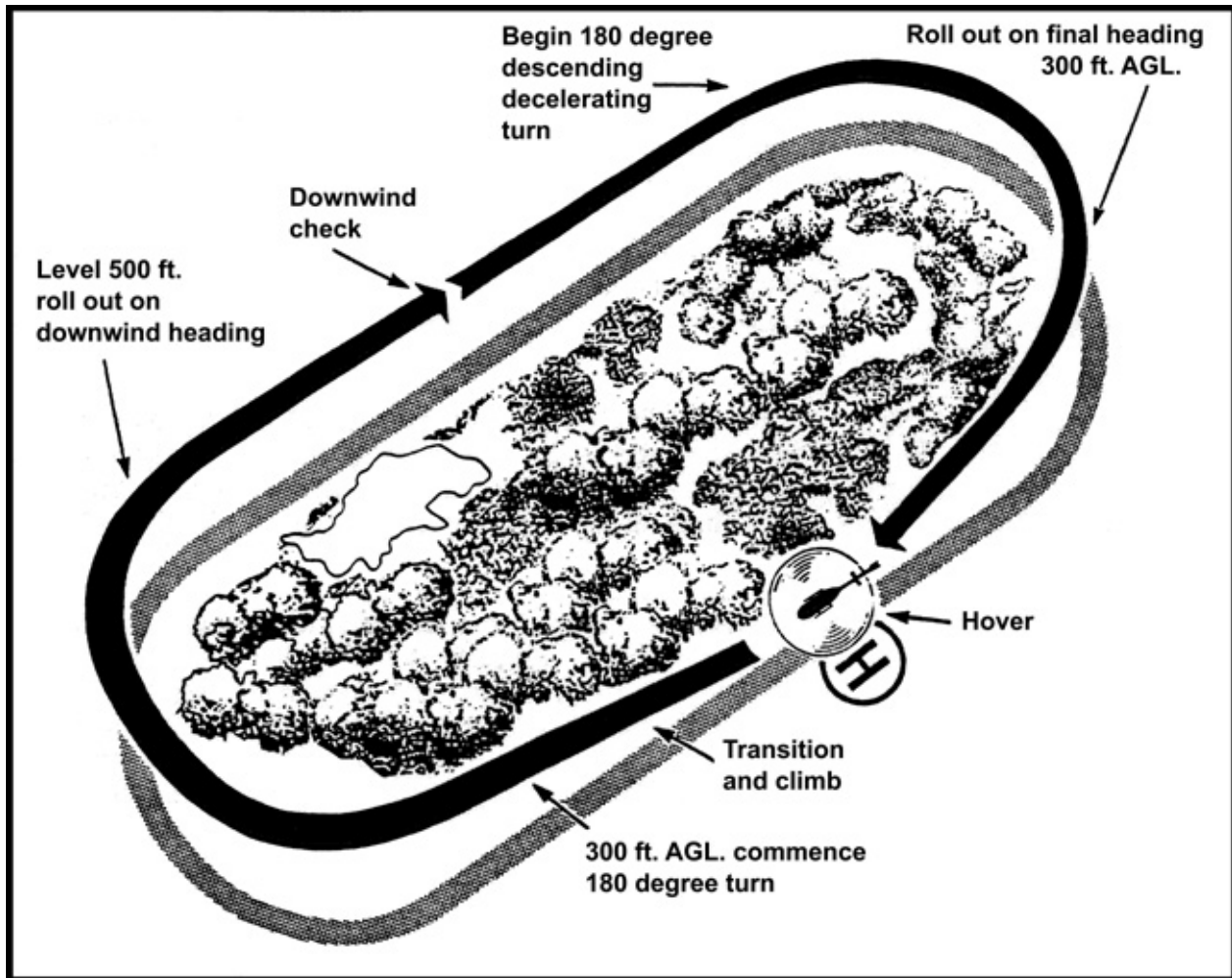

Figure 15-1: Typical Helicopter "Race Track" circuit

Lift the helicopter into the hover and perform a clearing turn, commence a standard transition, and:

1. at 300 feet begin a climbing 180° turn and roll out on the downwind leg at 500 feet AGL. The angle of bank should not exceed 30° and in fact should be varied according to the existing wind conditions, so that the downwind leg is approximately one-half mile from the take-off departure leg and parallel to it;
2. on the downwind leg, perform a pre-landing check. When you are flying circuits a radio call should be made on the downwind leg to advise the ATS, if you are at a controlled airfield, and other traffic of your intentions as to a landing or an overshoot; and
3. when the helicopter is at approximately 45° past the touchdown point, roll into a 180° descending decelerating turn to the final approach path to set yourself up at 300 feet AGL and 60 mph, approximately one-half mile back from the landing point. (The speed will of course vary according to type, but will generally approximate the best rate of climb speed).

SQUARE PATTERN

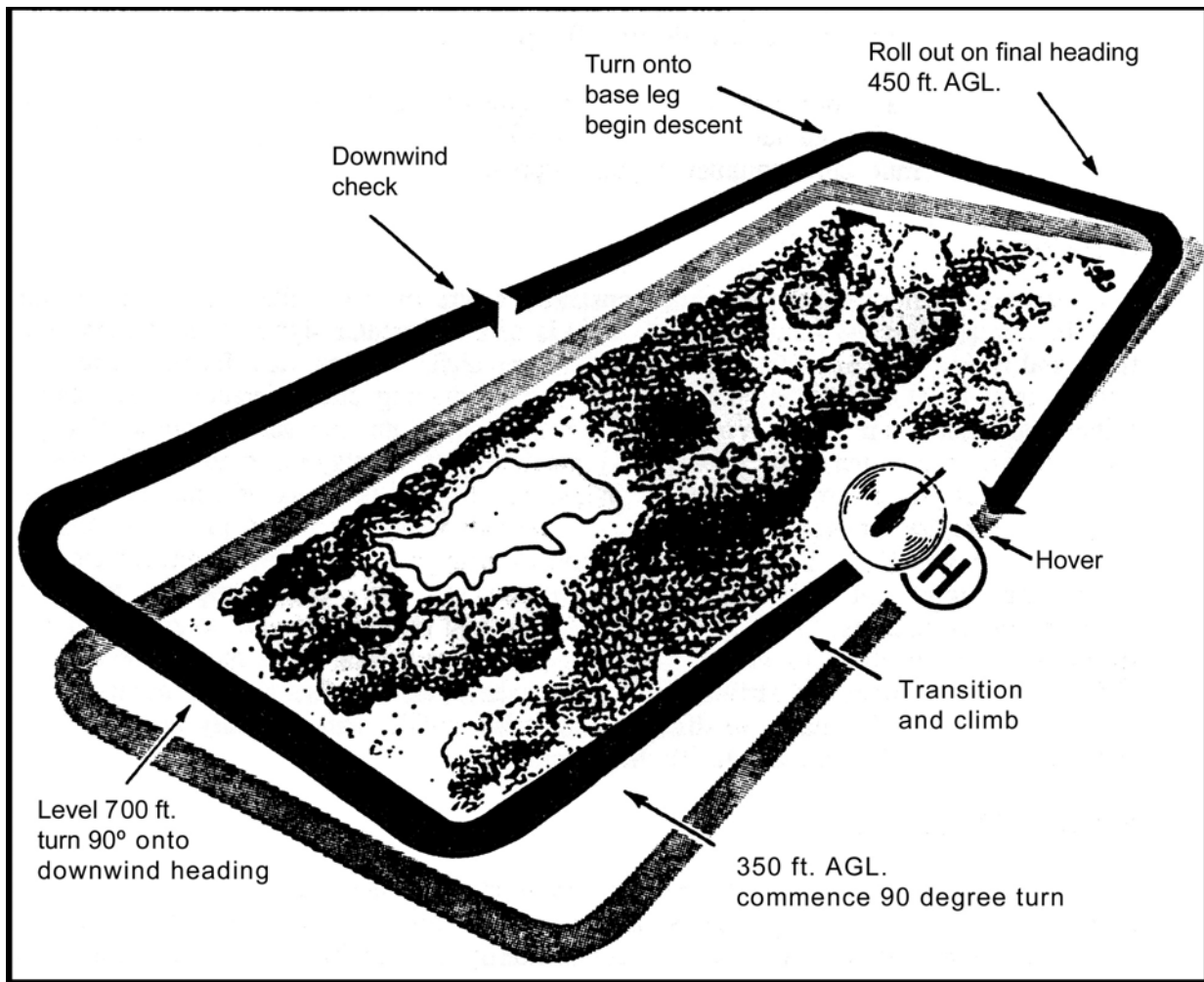

Figure 15-2: Typical Helicopter "square" Circuit

The square circuit varies slightly from school to school as far as heights to fly but the basic pattern is the same. The example below is just one variation.

Lift the helicopter into the hover and perform a clearing turn, commence a standard transition, and:

1. begin a 90 degree climbing turn at 350 feet AGL and roll out still climbing on to the crosswind leg. Level off at 700 feet AGL,
2. turn on to the downwind leg and perform a pre-landing check when abeam the intended touchdown point,
3. when the helicopter is 45 degrees past the touchdown point, lower collective to begin a descent and turn 90 degrees on to the base leg. At the same time, set the attitude for 60 mph, and
4. start your turn on to the final approach at 450 feet AGL, roll out when lined up with your take-off path at 300 feet and 60 mph, approximately one half-mile from the landing point.

SPACING

It is extremely important that you be constantly aware of the position of other aircrafts that may be operating at the same location. This is of even greater significance if there are fixed and rotary wing aircraft operating at the same airfield. You must fly your circuit taking into account other helicopters that may also be conducting circuit practice, and maintain a suitable distance from them. You may have to change your touchdown spot so that you do not interfere with their operations. Remember that displaying courtesy is also good airmanship. If you are operating at an airfield where there is a mix of both fixed and rotary wing, the exercise of good judgement and consideration for other pilots becomes most important. It will likely be necessary for you to arrange your circuit to remain clear of the fixed wing circuit, but seek approval from the ATS to fly a circuit opposite to that being flown by the aeroplanes. This may also mean that you may not be able to arrange the circuit so that you are directly into wind for the takeoff and approach. You may not encounter this difficulty at an uncontrolled airfield, but in any event, you will find that the ability to arrange your circuit so that it causes no disruption to other traffic, will not only be appreciated by other pilots, but will result in safe flight operations.

WAKE TURBULENCE

Numerous aircraft incidents and accidents occur at the busier airports as a result of wake turbulence, despite the many studies on the subject and the increased publicity among the pilot community. While these occurrences primarily involve light aeroplanes, the helicopter is also vulnerable if the pilot selects a flight path that intrudes upon the turbulence generated by airflow from the trailing edge of an aerofoil.

The vortex generated by an airfoil is proportional to the lift generated by the airfoil, its size, and angle of attack. The ratio of aircraft weight to aerofoil size also has a bearing on the vortex produced. A heavy aircraft with a small wing (and therefore a high wing loading) will produce intense vortices, while the longer and broader the aerofoil, the greater the area affected by the vortices.

This same principle applies to helicopters. Helicopter rotors trail the same twin vortices as a fixed wing aircraft, and the greater the helicopter's weight, the more intense will be its wake turbulence.

Speed affects the vortices inversely; that is: an aircraft flying at a slow speed will produce more intense vortices than when it is at cruise. We would therefore expect to encounter the most intense wake turbulence when aircraft are landing or taking off, although an S61 flying at 20 kts will also produce intense vortices while not necessarily landing or taking off.

These vortices tend to descend below the path of the aircraft producing them and spread apart. A wind, of course, will affect the vortices causing them to drift downwind, dissipating slowly in calm winds, and dissipating more rapidly in strong winds. It should be noted, however, that the movements of the vortices are not predictable with any degree of certainty.

To avoid encountering wake turbulence, the helicopter pilot should select approach or departure paths that are above the departure path of other, larger aircraft. Also, he should avoid selecting any flight path that would cause him to intersect the arrival or departure path of any aircraft capable of creating strong vortices, and particularly avoid below the flight path of other aircraft.

AIR TRAFFIC SERVICES (ATS)

Control zones have been designated around certain aerodromes to keep IFR aircraft within controlled airspace during approaches and to facilitate the control of VFR and IFR traffic. Control zones within which a radar control service is provided normally have a 7-mile radius. Others have a 5-mile radius, with the exception of a few which have a 3-mile radius. Control zones are capped at 3000 feet above airport elevation unless otherwise specified.

VFR aircraft require a clearance from an air traffic control unit or to establish contact with an ATS to enter a control zone. This clearance or instruction, however, does not relieve the pilot of responsibility for avoiding other aircraft, maintaining appropriate terrain and obstruction clearance, and remaining in VFR weather conditions. It is also a requirement that the aircraft be equipped with radio communication equipment capable of two-way communication with the appropriate air traffic control unit. In certain instances, NORDO operations may be authorized. You should consult your A.I.M Canada for details.

When you intend to conduct flight training exercises within a control zone, the ATS will likely ask that you:

1. remain on the frequency;
2. advise them of your intentions.

If you intend to depart the control zone, you should advise the ATS of your intentions, and they in turn will advise you when to leave the frequency.

Many control zones have established reporting points that VFR traffic may use to identify their position when transmitting to the ATS.

Your instructor will explain the procedure for using Mandatory Frequencies (MF) and Aerodrome Traffic Frequencies (ATF). At uncontrolled aerodromes, although there will not be an operating control tower, a Flight Service Station may be in place. The FSS does not exercise control over air traffic but only acts in an advisory capacity, providing information on winds, runway in use, known traffic, weather, etc. Some airfields will not be equipped with either a tower or a FSS, but will only have a "Unicom" frequency that may or may not be monitored. At uncontrolled aerodromes, pilots must use the appropriated frequency to transmit position reports and broadcast their intentions while operating in the zone.

FIRST SOLO

The first solo is a landmark in your flying career. You will never forget it and it is quite normal to look forward to it, but do not exaggerate its importance. It is not so much when you solo, but rather what you know and what you can do correctly at this stage of training that is important. Soloing is merely another step in the orderly process of training, bringing you to the stage where learning really begins.

Before being permitted to take your first solo flight, you will have to demonstrate to your instructor that you are able to:

1. take off and land reasonably smoothly and consistently vertically, with no yaw, sideways or rearwards drift. The hover should be steady and well controlled;
2. carry out a transition preceded by a clearing turn as a normal airmanship manoeuvre. Airspeeds and power settings should be well controlled and smooth;
3. fly a consistently safe and accurate circuit, and be able to correct any inaccuracies without assistance from your instructor;
4. fly a safe approach and be able to correct any large deviations from the selected approach angle. Reduce the forward speed smoothly and progressively. The approach should consistently terminate with a hover over the selected spot at the recommended hover height; and
5. be able to handle any emergency which may occur during the circuit.

As pilot-in-command you are responsible for the operation and safety of the helicopter during its flight time on solo flight. However, for this first solo your instructor will ensure that suitable conditions exist and precautions are taken. For example:

1. sufficient fuel, be sure the helicopter has sufficient fuel for the intended solo flight, with adequate reserve for possible delays;
2. light, sufficient daylight must remain for successful completion of the anticipated flight, allowing a liberal margin for possible additional circuits or delays due to other traffic;
3. weather, the first solo flight should not be considered unless suitable weather conditions exist, and are forecast to continue;
4. other traffic, at airports where unusually heavy activity exists at certain times of the day, it may be advisable to avoid a first solo at such time; and
5. fatigue, after a lengthy session of dual instruction, you may be so fatigued that it is inadvisable to consider a first solo flight, even though you may be performing satisfactorily.

Ensure that you securely fasten the seat belt and shoulder harness, if fitted, of the empty seat, so that there is no chance of the belts interfering with the collective or cyclic.

On a solo flight, you will notice that the lateral CG shifts somewhat and that the takeoff and transition will appear to be more rapid as the helicopter will be significantly lighter. This was the most noticeable feature of the first solo flight.

For a given power setting, you will find that the helicopter will climb much more rapidly and that a somewhat greater collective reduction is necessary to initiate a descent.

New manoeuvres and procedures will be added as progress permits, and further solo flights planned at intervals throughout your training. Specific practice on previously learned procedures, as well as new, will be included in these solo flights. When authorized and briefed to do specific manoeuvres, it is important that you practise this specific work diligently in order to develop safe flying skills. The objective of any solo flight must be to attain greater precision, co-ordination and judgement.

EXERCISE 16 - SIDEWAYS AND REARWARDS FLIGHT

One of the unique abilities of the helicopter is that of being capable of moving over the ground in a sideways or backwards fashion. For the pilot, the ability to fly the helicopter in this manner is fundamental to exploiting its manoeuvrability to the maximum.

If conditions allow, it is always preferable to hover-taxi forward rather than sideways or to the rear. It is obvious that your visibility is much better when facing forward than if you were moving in another direction and you will therefore be better able to identify and avoid obstacles that may intrude into the flight path. You will also be better able to handle an engine failure when the helicopter is moving forward with the skids tracking across the ground parallel to the direction of movement. It is important, during any hovering manoeuvres, to maintain a proper hover height. A number of manufacturers recommend 3 to 5 feet skid height. Helicopters with low inertia blades should generally be hovered at a lower skid height. In any case, the height should not be so low that the skids are in danger of contacting the ground or small obstacles, since a rollover may result if the helicopter is in motion.

When hover-taxiing your helicopter, maintain a speed that is about the same as a normal walking pace. Any faster and you may begin to encounter effective translational lift; control of the height will then be somewhat difficult as the helicopter will want to climb. Should this occur when taxiing sideways or to the rear, it is possible to exceed the manufacturers airspeed limitations for those directions. Fast taxiing to the side or rear will require judicious use of pedals to counter any weathercocking tendency. Remember that flapback can occur in any direction, not just in forward flight, and the pilot will have to overcome it in the usual manner when hovering to the rear or to the side.

SIDEWAYS FLIGHT

To commence sideways flight from the hover, proceed as follows (Fig 16-1):

1. pick two reference points, one to the front the other to the side to help you maintain the correct ground track. Perform a 90 degree clearing turn to look out, checking the area for any obstacles or other traffic;
2. apply a small amount of cyclic in the desired direction to begin the helicopter moving;
3. maintain the hover height with collective, preventing sink as the disc tilts;

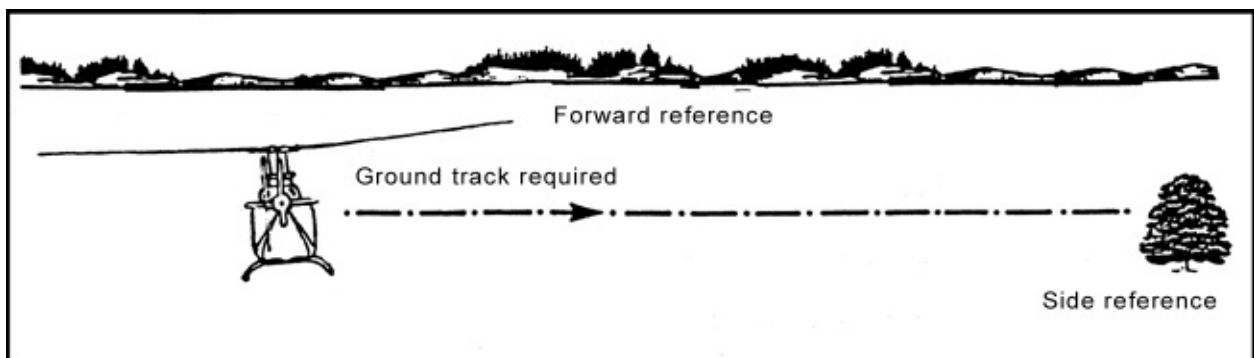

Figure 16-1: Sideways Flight

4. apply pedals as necessary to maintain heading and prevent yaw or weathercocking;
5. adjust the cyclic as required to overcome flapback and to keep the helicopter moving at a smooth, constant rate; and
6. alternate between looking forward to ensure the helicopter remains on the original heading and in the direction of movement for any obstructions.

To bring the helicopter back to a hover:

1. smoothly apply cyclic, opposite to the direction of movement, to select the hover attitude;
2. maintain a constant height with collective and the original heading with the pedals, pause; and
3. as the sideways motion ceases, adjust the cyclic to establish a steady hover and maintain the original heading.

REARWARD FLIGHT

Before commencing rearward flight, do a clearing turn of 90° or 180° to ensure that there are no obstacles in the proposed flight path, and to identify the point at which you will cease your rearward flight. Once you are satisfied that the area is clear, return to your original heading and after picking your reference points:

1. increase your hover height by 1 to 2 feet, to compensate for the fact that while moving to the rear, the helicopter's attitude will be tail low. This extra height will ensure adequate tail rotor clearance;
2. apply aft cyclic to begin rearward movement. Anticipate flapback with a further cyclic application to achieve a smooth constant rate of movement;
3. maintain height with collective and direction with pedals; do not attempt to look to the rear as this will only cause you to lose sense of the desired direction of flight; scan to the front and to the side to ensure that direction is correctly maintained.

To return the helicopter to the hover:

1. smoothly apply forward cyclic to select the hover attitude, pause;
2. as the helicopter comes to a stop, adjust the cyclic to hold the helicopter in a steady hover;
3. hold the heading throughout with pedals; and
4. once all motion has ceased, lower the collective slightly to re-establish normal hover height.

In the operational environment, there is seldom the need for lengthy rearwards hovering-taxi and if for some reason you must do so, it is good airmanship to periodically stop and do another clearing turn to check that the area is clear of obstructions. Be aware that in both turbine and reciprocating engine helicopters, exhaust fumes can enter the cockpit under certain wind conditions while hovering to the rear.

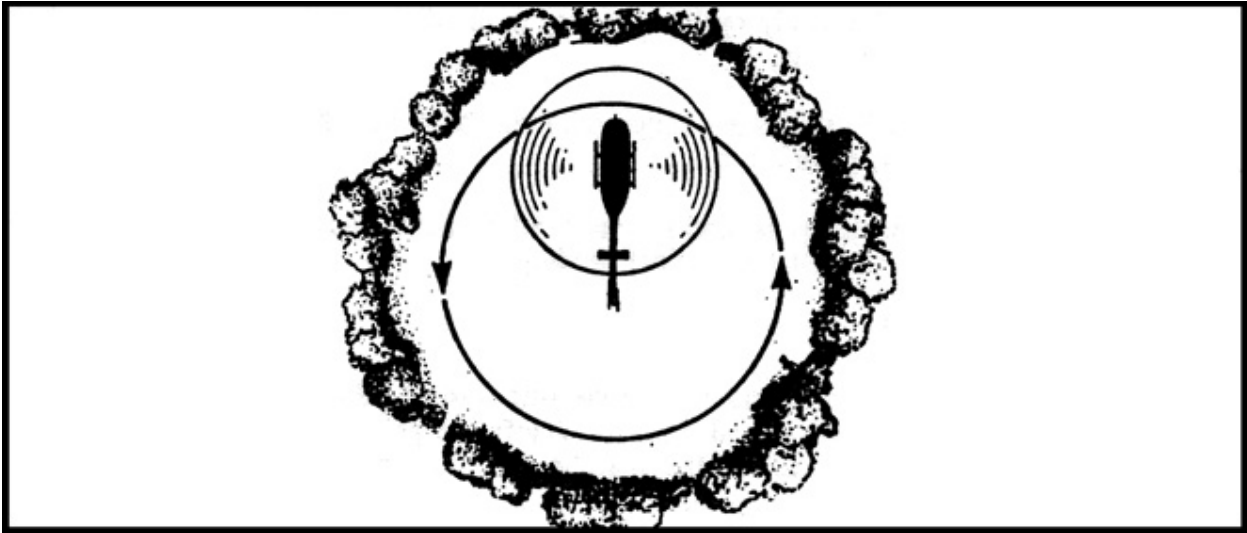

Figure 16-2: Turn around the tail

TURNS AROUND THE TAIL

This is a useful manoeuvre from an operational standpoint (Fig 16-2) and you will find that it is often used when required to re-position the helicopter within a confined area. The techniques are similar to those, which you employed in sideways hovering (See figure 16-1).

To commence this manoeuvre, look first in the direction that you intend to turn, ensuring that the area is clear of obstacles that could pose a hazard to the helicopter. While doing this, try to imagine that the cockpit of your helicopter is sitting astride the circumference of a circle with the tail of the helicopter at the centre of that circle. Unlike a turn around the mast, where in still wind the turn can be completed with pedal alone, you must now co-ordinate both the pedals and the cyclic to move the helicopter around the imaginary circle. Use the pedals to keep the tail over the centre while maintaining a slow walking pace laterally with the cyclic. Collective is used to maintain the normal hover height. Be aware that in any wind conditions the cyclic must be displaced into the wind.

TURNS AROUND THE NOSE

(Fig 16-3) This variation on the hovering-turn, you will also find extremely useful in the operational sense. To practice the manoeuvre, identify a spot on the ground close to nose of the helicopter; 10 to 15 feet will suffice. Avoid selecting a spot close in, as you will find, as in basic hovering, that it will be difficult to accurately control your height. Look in the direction you intend to move the helicopter to ensure the entire area is free of obstacles. The manoeuvre itself is similar to the turn around the tail, except the tail now sits astride the circumference of the imaginary circle.

Use the pedals to keep the nose pointed at the selected spot while effecting lateral movement with the cyclic. Maintain the correct hover height with the collective. Keep the movement slow and smooth as rushing turning manoeuvres will result in overcontrolling and you may exceed manufacturer's limitations.

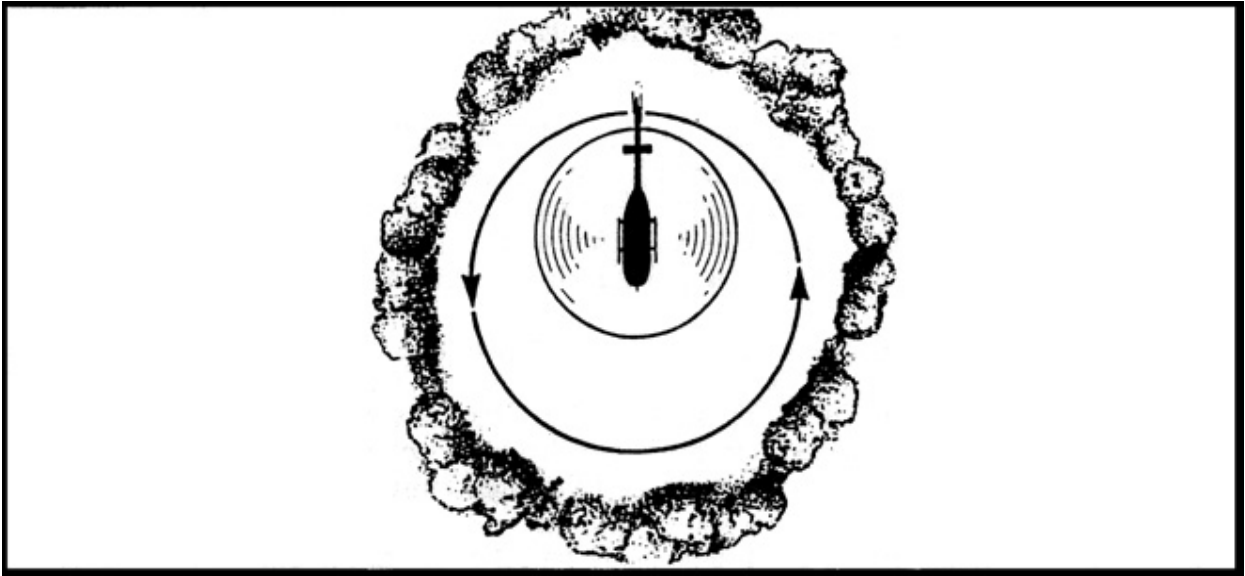

Figure 16-3: Turn around the nose

EXERCISE 17 - STEEP TURNS

Steep turns are a means of turning the helicopter in a relatively small area. The practice of these manoeuvres is excellent in developing the coordination of all three flight controls and the power control. It is important that you acquire the ability to execute them accurately and smoothly. Your instructor will demonstrate them in different operational flying situations.

Up to a limited angle of bank a steep turn may be executed without increasing power. However, in order to maintain a constant altitude, the airspeed must be sacrificed as a result of the increased aft cyclic pressure required to maintain that altitude. Remember that the greater is the angle of bank, the greater the amount of lift is required to maintain a constant altitude, therefore, additional lift is provided by an increase of power.

A steep turn is entered like any other turn but, as the angle of bank is increased beyond approximately 30°, you must increase collective in order to maintain height and airspeed. It requires simultaneous co-ordination of all three controls. Because of the rapid change of direction, the lookout for other aircraft before doing a steep turn is even more important than for other turns.

To enter a steep turn, first look out, then apply lateral cyclic in the direction of the desired turn and:

1. as the bank increases, move the cyclic aft to maintain the correct fuselage attitude relative to the horizon. (By so doing you have increased the aft tilt of the disc which, unless compensated for, will cause the airspeed to decrease);
2. to maintain the set airspeed, increase collective as necessary as the bank angle increases beyond 30°;
3. once the desired bank angle has been achieved, keep it constant with lateral cyclic.
4. maintain balanced flight (ball centred) throughout the manoeuvre with tail rotor pedals; and
5. maintain a good lookout.

To recover from a steep turn, proceed exactly as you would for any other turn, except that, as you roll off the bank, the collective should be reduced simultaneously with the return to straight and level flight. You must also relax cyclic backpressure to ensure that the helicopter does not climb as you roll out of the turn. Remember that these movements should be coordinated and smooth.

Should you find that the nose of the helicopter is tending to pitch down while in the steep turn, do not attempt to correct by applying cyclic backpressure alone since this will only serve to tighten the turn. Use lateral cyclic to reduce the angle of bank slightly, then correct the attitude with coordinated aft cyclic. Another frequent error is the application of too much aft cyclic before it is required when rolling into the steep turn, causing altitude control to be erratic.

EXERCISE 18 - AUTOROTATIONS 3 (RANGE VARIATIONS)

In preparation for this exercise, you should review the two previous air exercises on autorotations, Exercises 7 and 13.

In the preceding autorotational exercises, you found that to achieve the minimum rate of descent in most helicopters, you fly the autorotations at the manufacturer's recommended airspeed. However, under emergency conditions, this airspeed will not necessarily result in your reaching your chosen landing spot. In fact, under actual emergency conditions, it will often be necessary to vary the airspeed, change the direction of flight, or employ some other combination of airspeed and turns in order to reach the spot. For example, should the landing spot be a small clearing in a wooded area, considerable manoeuvring may be necessary if you are to effect a safe landing. For this reason, you should take advantage of the helicopter's capabilities in autorotative flight.

AIRMANSHIP

Prior to conducting an exercise of autorotations, it is recommended to roll off the throttle once while the helicopter is on the ground. This will confirm that the clutch or freewheeling unit is operating correctly, and that the engine is not going to quit. Always choose a large, level area for the full on with plenty of safety margin.

In the air, a confirmation of the selected area should be followed by the HASEL check.

Prior to conducting this exercise, your instructor will review with you the speeds, rotor RPM, and VNE according to your helicopter type. The maximum range speed will also vary depending on the helicopter types. (Refer to Figure 18-1).

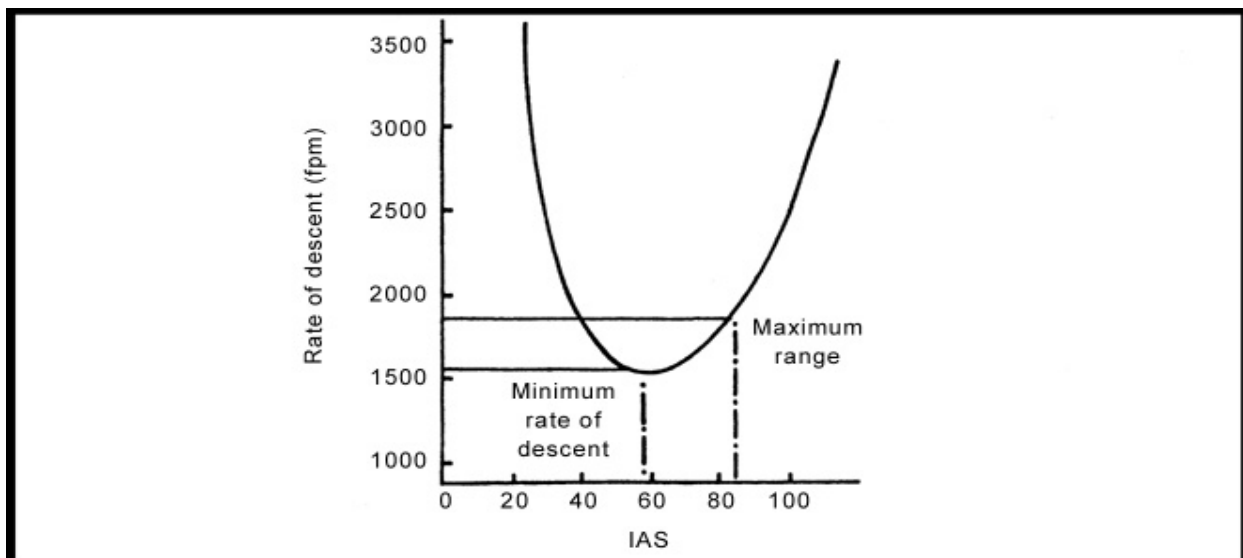

Figure 18-1: Rate of descent vs. forward speed in autorotation

EXTENDING THE RANGE

Many helicopter manufacturers specify a maximum autorotation range speed in their flight manuals (Fig 18-2). It is this speed that you should reference when performing this exercise. There is certainly no purpose in exceeding that speed, as after that point, no increased range will result. Indeed rate of descent will increase range will decrease.

You will also note that, although the rate of descent is higher, the distance covered over the ground is appreciably greater.

To enter and practise a range autorotation, after completing the checks, proceed as follows:

1. from cruise speed into wind, give the verbal warning "Practice engine failure", lower collective while smoothly rolling off throttle to idle;
2. at the same time, adjust cyclic to set the airspeed for maximum range and maintain balance with pedals;
3. check the RRPM frequently, particularly in turns, and make any collective adjustments to maintain the RRPM within limits;
4. maintain the range speed throughout until the spot can be made, then reduce the speed to the minimum rate of descent speed. This will reduce both forward speed and the rate of descent; and
5. Flare, level and land the helicopter as previously taught.

Try to return to the minimum rate of descent speed as early as possible (by 200 feet AGL). Should you hold the maximum range speed down to flare height, you would find that the flare would have to be maintained longer in order to reduce the ground speed to acceptable level for the touchdown.

MAXIMUM RANGE AUTOROTATION

By reducing RRPM using collective the range can be further extended, but the rotor tachometer has to be closely monitored (Fig 18-2). In this instance, it is even more important to return to normal autorotation limits as soon as the landing spot is assured.

REDUCING THE RANGE

You will learn two methods of reducing the range in autorotation during this exercise:

1. reducing the airspeed; and
2. turning.

1. Reducing the airspeed (Fig 18-2):

The procedures are the same as other autorotations until after the entry, then as the helicopter enters autorotation, apply aft cyclic to reduce airspeed. It is possible to perform an autorotation at zero airspeed, but the rate of descent increases rapidly, and yawing may develop that is difficult to control because of loss of 'keel surface effect'. During low speed autorotations it is permissible to have a negative groundspeed but **NEVER** a negative airspeed, so be sure to maintain some indicated airspeed. Select a reduced airspeed that will enable you to make your selected landing spot. You will practise this manoeuvre with speeds down to 10-15 mph with your instructor.

Notice that the rate of descent, in this type of autorotation, is significantly higher than with one flown at the minimum rate of descent speed. For that reason, it is important to increase the airspeed, to that for minimum rate of descent, as soon as you are assured of reaching the selected touchdown spot. This will have the effect of reducing the rate of descent to that which will allow you to safely flare the helicopter and land. Remember to abide by the height/velocity diagram when performing autorotations. Therefore, ensure that the airspeed is increased to the minimum rate of descent speed in order to remain outside the "Avoid" areas. As a rule of thumb to increase airspeed by 10 mph requires 100 feet of altitude.

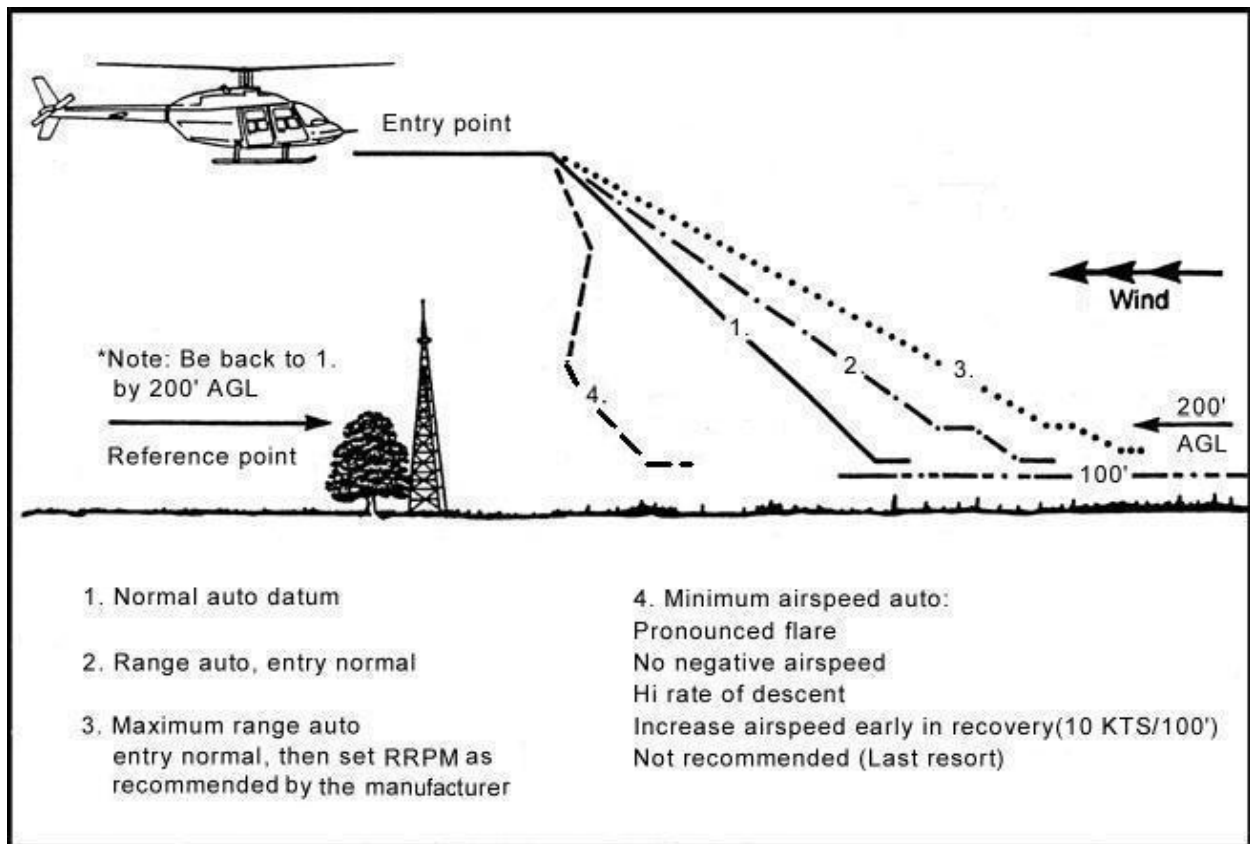

Figure 18-2: Range variations

2. Turning (Fig 18-3):

It is also possible to shorten the range of an autorotation by turning the helicopter. When using turns to reduce the range, bear in mind that the increased disc loading can cause a rapid increase in the RRPM. Monitor the RRPM to ensure that the limits are not exceeded; it may also be necessary to raise the collective slightly to prevent overspeeding the rotor, but reduce it again as soon as possible to conserve RRPM for the landing.

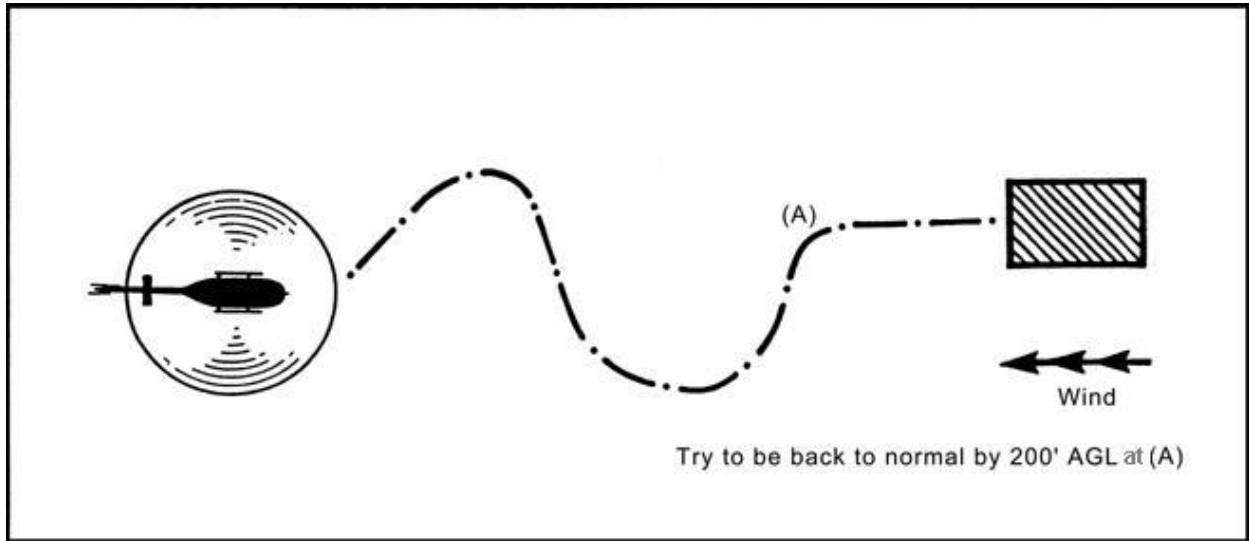

Figure 18-3: Shorten the range by turning

In addition to shortening the range of an autorotation, turning will greatly increase the rate of descent. Consider this fact when judging the distance to the desired touchdown spot, as this will determine what type of manoeuvre will allow safely reaching that spot. Figures 18-4, 18-5 and 18-6 represent different examples of turning autorotations.

Rates of descent in tight-turning autorotations can build up to more than 2500 feet per minute in some types of helicopters.

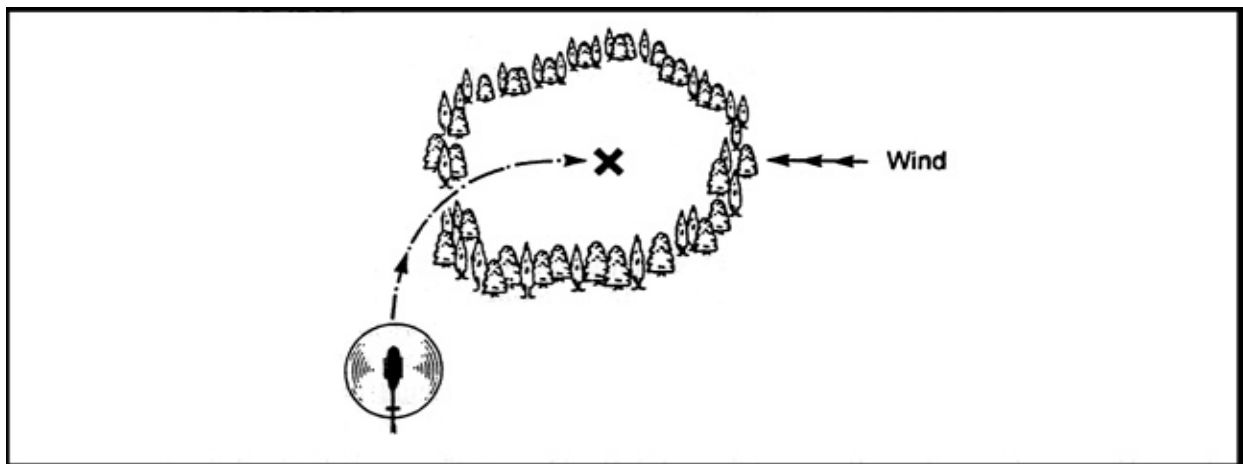

Figure 18-4: the 90-degree turning autorotation

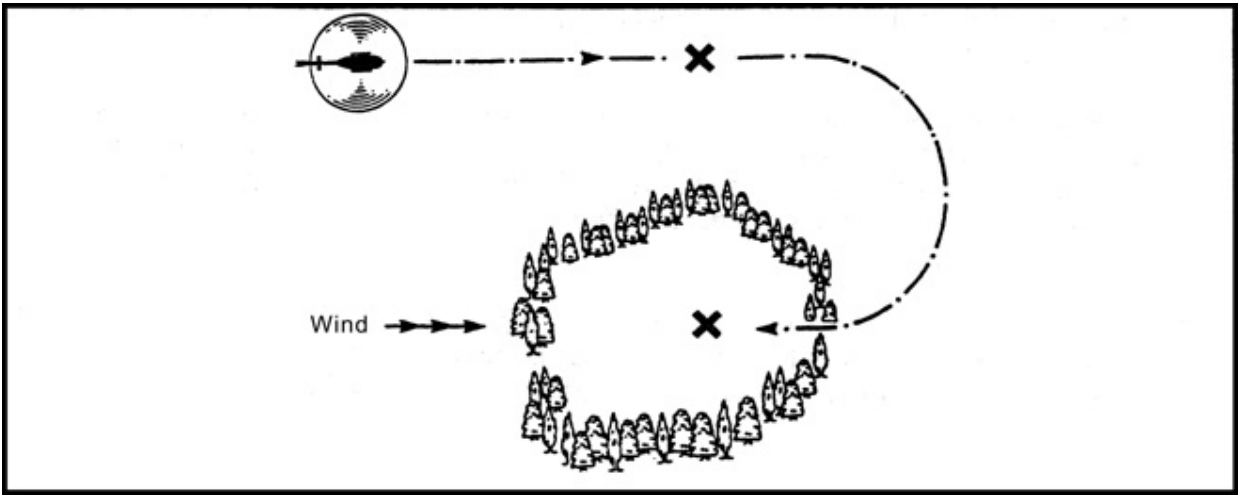

Figure 18-6: the 180-degree turning autorotation

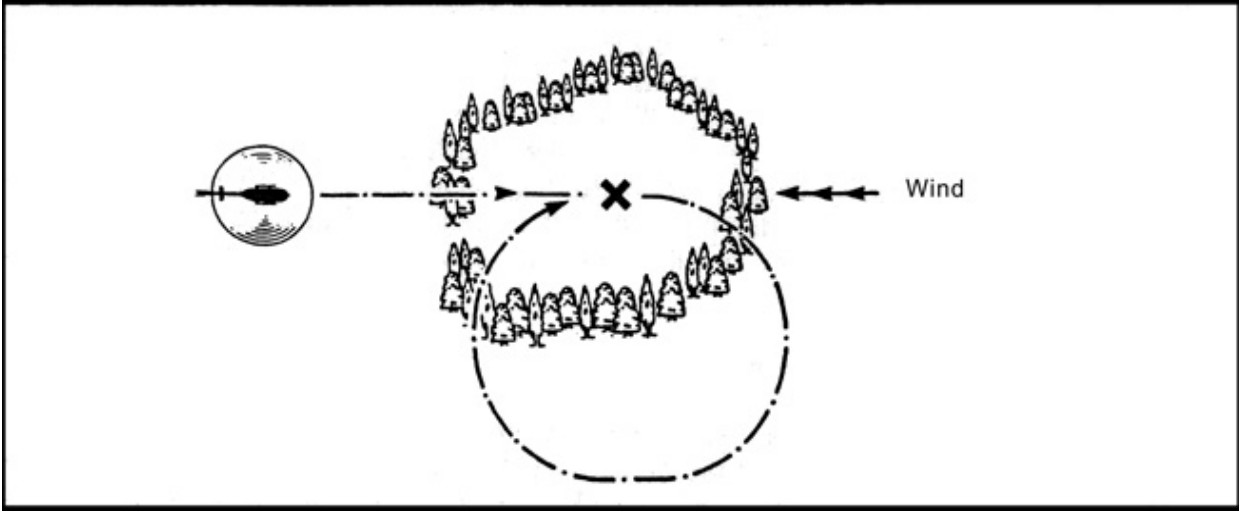

Figure 18-5: the 360-degree turning autorotation

EXERCISE 19 - PRACTICE FORCED APPROACHES

Practice forced approaches, as the name suggests, are the practical application of the autorotation and emergency exercises which your instructor has previously taught you.

During this exercise, you will be shown how to apply these skills to any emergency situations simulated by your instructor. The most common is the surprise engine failure. Your instructor will teach you the actions to be taken should the engine fail. The instructor normally simulated by twisting off the throttle; at that time:

1. enter autorotation by fully lowering the collective, setting the best rate of descent speed with cyclic, and adjust the pedals to control the yaw;
2. select a landing area, obviously the larger and flatter, the better, if possible into the wind;
3. adjust the controls to make the selected area, using the techniques shown in the previous lessons on autorotation to achieve that landing spot (Fig 19-1); and
4. either land, or overshoot using the power recovery technique if in simulated practice.

The points listed above are the minimum actions that must be completed to ensure the best chance for a successful forced landing. There are other actions that should be completed, given that you have sufficient altitude and time to perform them:

1. transmit a MAYDAY call, an example is shown at the end of this exercise;
2. if possible, identify the problem and take appropriate action to rectify it;
3. warn the crew and passengers, ensure they are told to brace themselves; and
4. switch off fuel, battery and generator, prior to attempting the landing.

Quite obviously, there may be other factors, which are going to affect the choice of site, and these will be discussed with you in detail. There are some, which deserve mention, for example; the wind, mountains, built-up areas, heavily forested terrain and water. As you can see there is quite a lot to think about when making your decision.

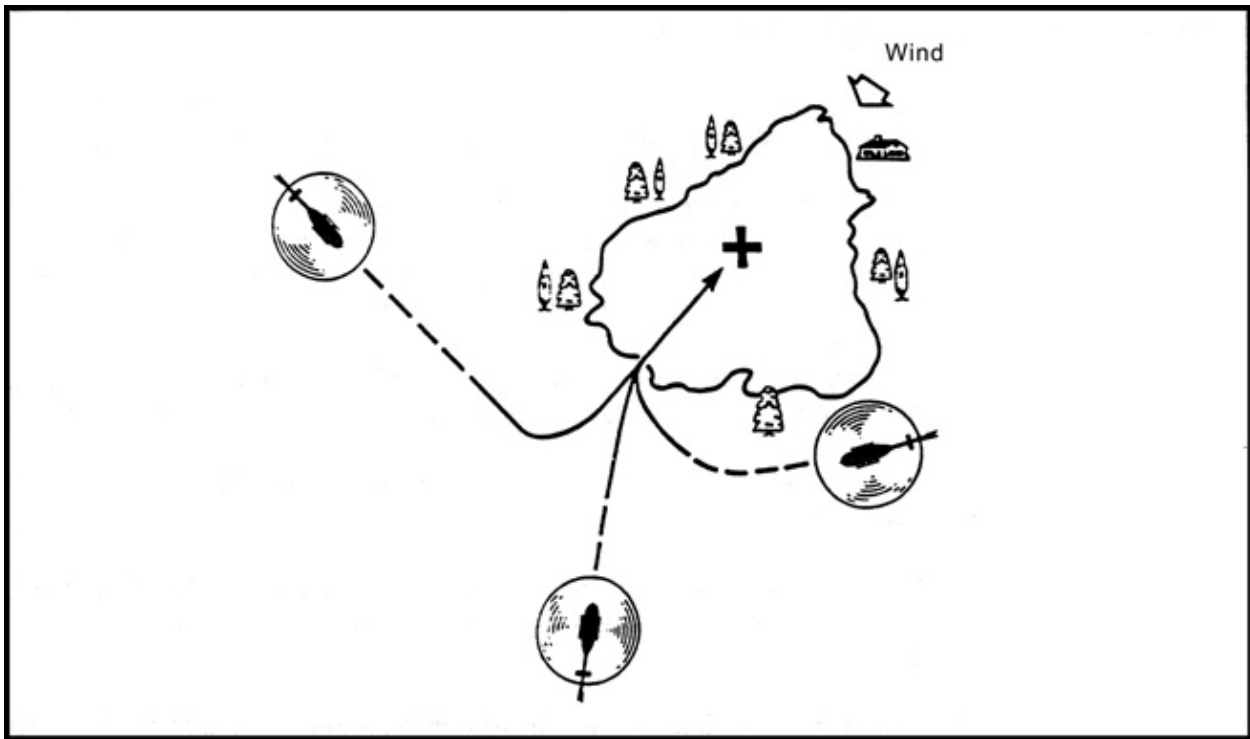

Figure 19-1: Forced Landing Approach

DISTRESS CALL

Each time you conduct a simulated engine failure a simulated MAYDAY call should be made. This will gradually become a reflex action, spoken automatically in the event of a real emergency. If time does not permit a full call, even a partial transmission could make the difference in the response of rescue personnel. Your simulated MAYDAY call should contain the following:

MAYDAY Prefix:	“MAYDAY, MAYDAY, MAYDAY”
Aircraft Identification:	“GABC, GABC, GABC”
Nature of Distress:	“Engine Failure”
Intentions:	“Autorotating to side of lake”
Present Position:	“10 miles north-east of Franz”

Always try to fly as high as the task and common sense allow. This gives much more real estate in which to pick a landing site. Flying low level over obstacles usually results in a forced landing that is difficult to successfully complete.

EXERCISE 20 - PILOT NAVIGATION

One significant advantage that an aircraft has over surface transportation is that it is capable of proceeding more or less directly to its destination at a constant and relatively high speed. To use this capability effectively, however, it is essential to be proficient in cross-country navigation. The first stage of this skill is a combination of practical navigation and map reading called pilot navigation. This involves the capability of piloting an aircraft a reasonable distance over relatively unfamiliar territory with a minimum of apprehension and a maximum of pleasure.

You must demonstrate competence in solo cross-country flight in order to be issued a pilot licence, but this will be preceded by dual instruction on all phases of the exercise. The success or failure of a cross-country flight hinges upon the ability to:

1. plan the flight, taking into account present and anticipated weather, terrain, distance involved, and your level of competence as a pilot;
2. establish and maintain a planned heading and altitude;
3. recognize the effect of drift, and competently estimate new headings to regain and maintain the desired track, or fly direct to your destination;
4. calculate ground speeds accurately and revise your estimated time of arrival (ETA);
5. read charts and identify physical features on the ground, and more specifically, correctly identify predetermined and new check-points; and
6. recognize the need to divert from a planned route and estimate a heading and ETA to an alternate heliport, or landing site, with a minimum of delay or confusion.

The foregoing points are difficult to put into any set order of importance, since changing situations would force a change in that order. For example, when a flight is conducted over terrain or in weather conditions which make map reading extremely difficult, an ability to hold a heading accurately and correctly calculate ETA'S becomes of overriding and vital importance, either in continuing the flight, or diverting to an alternate destination.

PREPARING FOR THE FLIGHT

The success and enjoyment of a navigation flight depends greatly on systematic preparation and planning. There are several factors to consider which may vary with the conditions under which the flight has to be conducted. The weather, terrain, landing sites, and fuel facilities, together with the availability of en route check-points, may influence decisions and we recommend that you carry out itemized preparation, study, and calculations for the flight, in the following order:

1. weather;
2. route selection;
3. NOTAM's and landing site condition reports;
4. aeronautical chart preparation;
5. flight log preparation; and
6. filing of a flight plan or flight itinerary.

WEATHER

Pilot navigation flights must not be conducted unless VFR weather prevails and is forecast to prevail over the selected route. Therefore, you must obtain adequate weather information. They may be obtained by different means and sources. Be sure to check the actual reports against the forecast weather for aerodromes at which you intend to land and along the selected route. Pay particular attention to the winds. The strength of the wind could play a vital part in your flight planning. Weather conditions are always subject to change; therefore, regardless of meteorological forecasts, in preparing for a cross-country flight, plan the possibility of having to divert to an alternate landing site. This may be done by listing all the suitable alternate landing sites along the route in chronological order on the flight log form. They may also be circled on the navigation chart.

CHARTS

The chart used almost exclusively for pilot navigation is the Transverse Mercator Projection, with a scale of 1:500,000. With this scale, 1 inch on the chart represents 500,000 inches on the ground (approximately 8 miles to the inch). Other scales you may encounter are 1:1,000,000 (approximately 16 miles to the inch) and 1:250,000 (approximately 4 miles to the inch). For fine detail, the 1 mile to the inch chart can be used. This chart even shows individual buildings, and is particularly useful for helicopter operations. The 1:500,000 statute mile scale does not exactly correspond to 8 miles to the inch, which is 1:506,880. For short distances the differences may be ignored.

THE ROUTE

Once you have determined that the weather for a flight will be satisfactory, all pertinent factors must be analyzed and a route decided upon. The most direct route may not be the most desirable; it could be largely over water beyond gliding distance from land, or over a prohibited or danger area. Refuelling stops will play a large part in selecting the route as most helicopters only have fuel for relatively short legs.

In selecting routes, try to avoid those, which include extended periods of flight over areas where map reading is difficult. The ability to read maps is a very important part of pilot navigation. The objective is to get there safely. "As quickly as possible" is an aim that can be sacrificed for this objective.

A checkpoint or pinpoint is a prominent feature or group of features along, or close to the route, used to establish the position of the helicopter. They are also used for other purposes such as in-flight calculation of ground speed and revisions to the ETA.

Main highways, rivers, railroads, and lakes afford excellent and readily identifiable checkpoints for pilot navigation. Take full advantage of them and choose a route, if possible, which will encompass most of them. In the event of any situation that requires diverting from the original flight plan, a pilot strengthens his hand considerably when he knows exactly where he is at the time the diversion must be made.

It is important that the aeronautical chart used is up-to-date and not so dog-eared from use that important details are obscured. Many experienced pilots augment aeronautical charts with information from current automobile road maps, since the latter invariably include more up-to-date secondary roads and highway detail. Remember to use road maps only as a secondary source of information, as distance scales and physical land features are not always displayed accurately.

PREPARING THE CHART

Once you have selected the appropriate current aeronautical chart(s) and decided on the route, draw the “required track” lines from the point of setting heading through intermediate points to the destination, and determine the true tracks and distances. The required track lines should be drawn in a way that makes them easily distinguished from printed chart detail and yet does not hide chart features. A highlighter pen can be used to emphasize the track line drawn on the chart.

Determine distances, then examine the route carefully and note the following:

1. elevation of terrain, with particular attention given to hills, peaks, ATSS, hydro lines, and other obstructions;
2. danger and prohibited areas;
3. other aerodromes and/or landing sites; and
4. location, availability, and distances between checkpoints.

To assist in assessing in-flight deviations from track and making corrections, drift lines could be drawn on the chart. These are lines drawn on the chart at 10 degrees each side of the required track line from both the set heading and destination points. They are described in detail later in this text, but can be seen drawn on the chart in Figure 20-1. A preferred set-heading point is an easily identifiable or known landmark, such as a railway or road intersection, a bend in the river, a ATS, a small village or lake, to which the pilot can “eye ball” his way to set heading. Accuracy on setting heading is essential. Setting heading from the downwind leg is not acceptable if the track line originates from the centre of the heliport symbol on the chart, as a half to 1 mile track error could exist from the start.

For rapid distance calculations, the track line drawn on the chart should also be marked into 10 miles intervals (Fig 20-1). Another method is to strike a line across the quarter, mid, and three-quarter waypoints of each track segment. Both these chart-marking systems are to aid mental time, distance, and track error calculations.

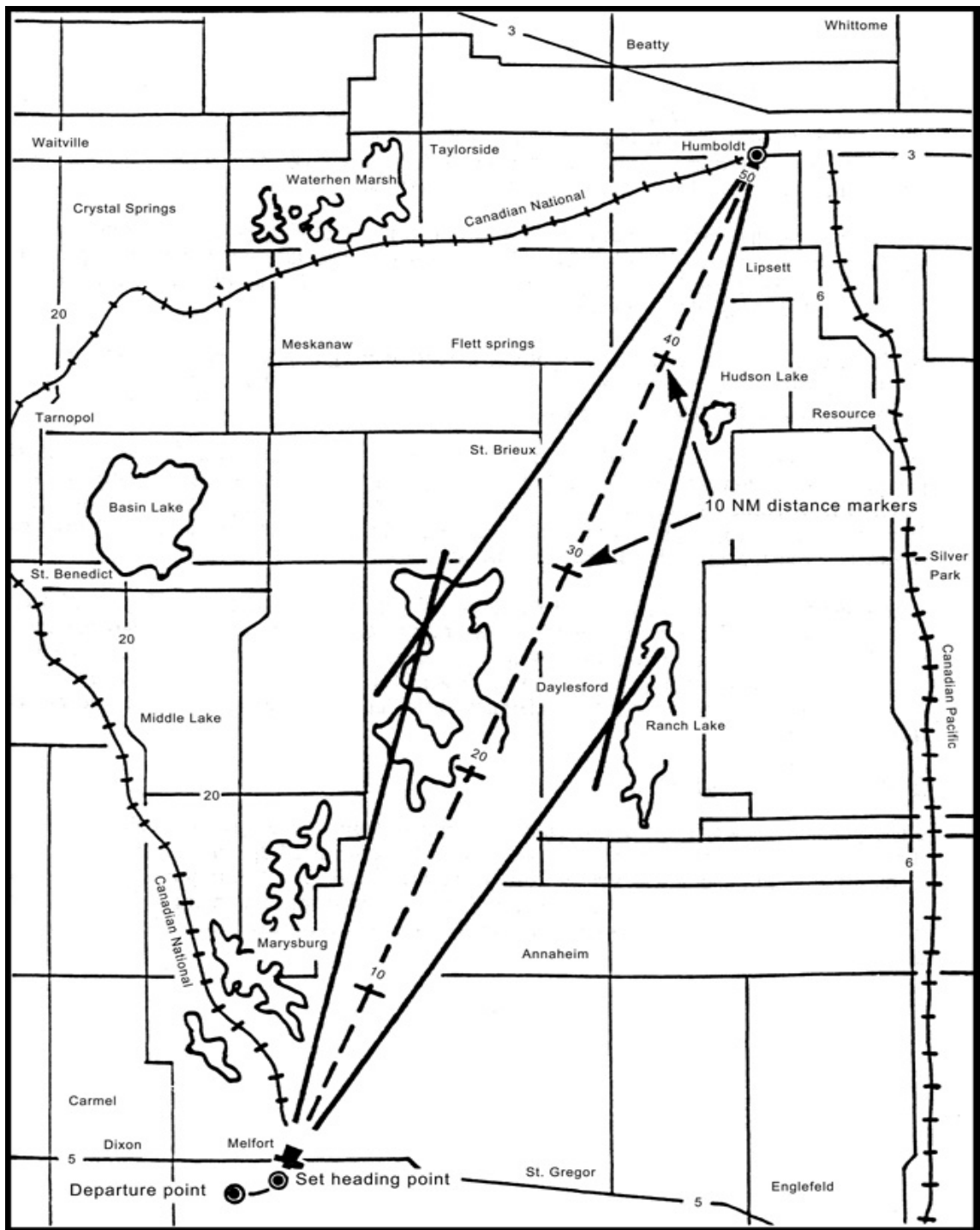

Figure 20-1: Chart preparation using 10-degree lines

THE FLIGHT PLANNING FORM

As information relating to the proposed flight is accumulated, enter it in the appropriate sections of a flight planning form. Figure 20-2a shows how the planned flight from Melfort to Humboldt would be entered. The cruise altitude of 4,500 feet, and true airspeed, track, and wind velocity can be entered, and the remaining figures can be added as they are obtained through measurement or calculation. Other pertinent information, particularly weather and landing details, can be added for current and future use.

FLIGHT PLANNING FORM													(1)	
From	To	Alt.	IAS	TAS	Track (T)	W/V	Hdg. (T)	Distance /speeds in				kts.	✓	
								Var.	Hdg. (m)	G/S	Dist.	mph	Fuel Req'd	
MELFORT - CHECK PT #1			80	-	080			17E	063		3	3		
CHECK PT #1 - HUMBOLDT		4500	90	98	024	290/20	012	17E	355	97	50	31	12	
												34	12	

Weather Forecast YXZ/YPA 50 SCT TO OVC 6-8 RW- OCNL GUSTS 30 3-290/20 + 10	En Route Radio Frequencies and Navigation Aids YPA VOR 113.0 YXE VOR 116.2 THX 118.3	Destination Information YXE 40 SCT OCNL 6 RW- Forecast W/V 275/20 + 25
En Route Stations Reports	35' TOWER 1 MILE N OF HUMBOLDT	HUMBOLDT - 072° RADIAL YXE VOR PHONE YXE FOR NR 306-663-4265 FLIGHT PLAN YXE 306-242-8227

Figure 20-2a: Flight planning form

TRACK LINE MEASUREMENT

One of the properties of a Transverse Mercator Projection is that scale can be considered constant all over the chart. Because of this the meridians of longitude, (the vertical lines), converge at a point above the top of the chart, and for that reason a straight line drawn on the chart meets each meridian at a slightly different angle. To offset these differences, place the protractor at the midpoint of the track line when measuring that angle. This is particularly important when the track line is long and runs parallel to the parallels of latitude.

AIRSPEED CORRECTIONS

True Airspeed (TAS) is used for navigation computations since indicated Airspeed (IAS) varies with temperature, pressure, and altitude. Conversion of IAS to TAS (or vice-versa) can be done very rapidly on your circular navigation computer. Because most helicopter operations are conducted at relatively low altitude, quite often IAS is used, as the differences are minimal.

WIND VELOCITY (W/V)

In aviation terminology, the term wind velocity, usually abbreviated to W/V, implies both the direction of the wind and its speed. Wind velocities normally change with altitude and, in planning a cross-country flight, this must be taken into account when preparing the flight planning form. Many factors affect the selection of the altitude(s) at which a flight will be conducted and W/V is a major one.

NAVIGATION LOG

With the W/V selected for the altitudes to be flown, calculate headings, ground speeds and times and then fill out the navigation log (Fig 20-2b). Itemize all tracks, headings, distances, speeds, times, etc., pertinent to the flight. This provides an organized record and schedule for the flight and minimizes the possibility of forgetting important data and having to compute problems in flight. Fuel requirements should be calculated, and while en route these calculations should be checked against actual consumption to determine if the calculated reserves will be available at the destination. There are various forms of flight planning forms and navigation logs, each designed for a particular purpose. Your flight instructor, who will also assist in their preparation, will supply the training organization forms.

The Navigation Log

The helicopter pilot has little time for log keeping in the air (Fig 20-2b), but the following are some of the items that should be recorded, although this may not be possible in most types of helicopter:

1. each compass heading (use 3 digits - i.e., 037);
2. the time the helicopter sets out on each compass heading;
3. ETA at destination and planned turning points;
4. time over or by check-points and turning points; and
5. new ground speeds and revised ETA.

NAVIGATION LOG		Distances/speeds in					kts. mph	
From	To	Alt.	IAS	Track (T)	W/V	Hdg. (M)	Dist.	D.R. time
MELFORD - CHECK PT. #1		↗	80	135	290/20	→	3	3
CHECK PT. #1 - HUMBOLDT		4T	90	204	290/20		43	30
							46	33
FLIGHT LOG								
Time	Hdg. (C)	Observations					Actual G/S	E.T.A.
1255	118	OFF MELFORD						
1300	195	OVER CHECK PT. #1 S/HEADING					88	1322
1307		2 MILES E. OF ST. BRIEUX (6°R)						
1307	183	A/HDG TO REGAIN TRACK (2 × 6°) = 12°L						
		G/S 14 MILES IN 8 MIN.					101	1322

Figure 20-2b: Navigation Log

FLIGHT PLAN AND FLIGHT ITINERARY

It is mandatory that a flight plan or flight itinerary be filed prior to any flight beyond 25 miles of the departure's point. Among other things, this ensures that the appropriate authorities are alerted should the helicopter become overdue. Air searches can involve considerable time and expense. It is imperative that the pilot closes his flight plan/flight itinerary by notifying the appropriate agency when the intended or alternate destination is reached.

GENERAL TECHNIQUE

In this text, we do not intend to discuss all the details involved in conducting a pilot navigation flight since the training unit will provide appropriate instruction by means of dual navigation exercises. However, the following are some general points applicable to any cross-country flight.

Magnetic Compass

When you read about vagaries of the compass later in this chapter, you will note that this navigation instrument may be unreliable while the aircraft is being turned, banked, accelerated, or decelerated. Therefore, in order to maintain the all-important heading of an aircraft by means of a magnetic compass, the helicopter must be held straight and at a constant airspeed.

Compass Turns

Compass readings are unreliable when the helicopter is turning. Dependent upon individual aircraft design a turn of more than, or a fraction of, 90 degrees can be estimated by using the angle between the nose of the helicopter and the 9 o'clock and 3 o'clock position as a guide. For example, a turn of 100 degrees to the left can be made by turning on to a reference point which lines up with the 8:30 clock code position.

Heading Indicator

This instrument is subject to the precession errors. The heading indicator must be set manually by the pilot to the magnetic compass and reset about every 15 minutes. It is important to set the heading indicator accurately WHILE IN STRAIGHT FLIGHT.

Altimeter

Atmospheric pressure varies from time to time, and place to place; therefore the pilot must reset the altimeter to compensate for these variations. Current altimeter settings may be obtained on request from control ATIS and Flight Service Stations, or by tuning in to Automatic Terminal Information Service (ATIS) broadcasts.

MAP READING

The generally accepted term to describe navigation by means of a chart is map reading, although the publication used is more correctly called a chart than a map. You will begin to gain experience in map reading during earlier air exercises and learn it progressively, first by identifying highways, railroads, or rivers and relating them to other prominent features on the ground such as towns, airports, power lines, etc. Then, as your ability increases, a specific compass heading should be maintained while reading a chart.

Arrange charts so that both the charts and the controls of the helicopter may be easily managed at the same time. A chart should be folded so that the section being used is readily available, with a minimum of refolding or handling in the air. If more than one chart is to be used, they should be pre-arranged in the order in which they will be required. Align the chart so that the required track on the chart will be parallel to, and pointing in the same direction, as the track being flown.

The recommended practice in navigation by map reading is “from watch to chart to ground”, in other words, noting the time, studying the chart, and anticipating what is to be seen on the ground. There are times, however, such as when you are lost, when the reverse procedure is more valuable, i.e., relating features on the ground to features on the chart. A great deal of practice with both methods is required at varying altitudes and on different headings.

Estimating

To become proficient in pilot navigation, you must develop the ability to estimate. This can only be done through practice and more practice. While in flight, estimate the bearing and distance the helicopter is from a heliport, town or check-point, observe the natural signs of surface winds and estimate their direction and strength; estimate the size of objects on the ground and the distance they are from each other. When passing near a spot that you could consider for an emergency landing, estimate its suitability. Look quickly at a chart and estimate the distance that a certain lake is from the helicopter, what heading will be required to fly to it, and how long it will take to get there.

The more you know about the subject of navigation, the easier and more accurate estimating will be.

Tracking Errors and Corrections

Owing to inaccuracies in the forecast wind and in flying the helicopter, errors often occur that require alterations of heading to bring the helicopter to the destination. Before corrections are discussed, the following terms must be defined:

1. Required Track. The proposed path of the helicopter over the ground.
2. Track Made Good. The actual path of the helicopter over the ground.
3. Track Error. The angle between the required track and the track made good, measured in degrees, and always expressed as being left or right of the required track.
4. Opening Angle. The angle between the required track and the track made good.
5. Closing Angle. The angle between the old required track and the new required track to arrive at the destination.

Ten Degree Drift Lines

In Figure 20-1, 10-degree drift lines are shown opening up from the set-heading point and closing down to the destination. These lines enable the pilot to estimate track errors and required heading changes with reasonable accuracy.

Point A in Figure 20-3 indicates a point on the track made good which is 7 degrees to the left of the required track, indicating an opening angle of 7 degrees. The angle can be estimated more accurately by imagining or physically making a mark at the mid-angle of 5 degrees (line B) and establishing the pinpoint in relation to that mark. Closing angles may be determined in the same manner, using the 10-degree drift lines, which converge on the destination. The angle between the required track and a line joining Point C to destination indicates a closing angle of 4 degrees.

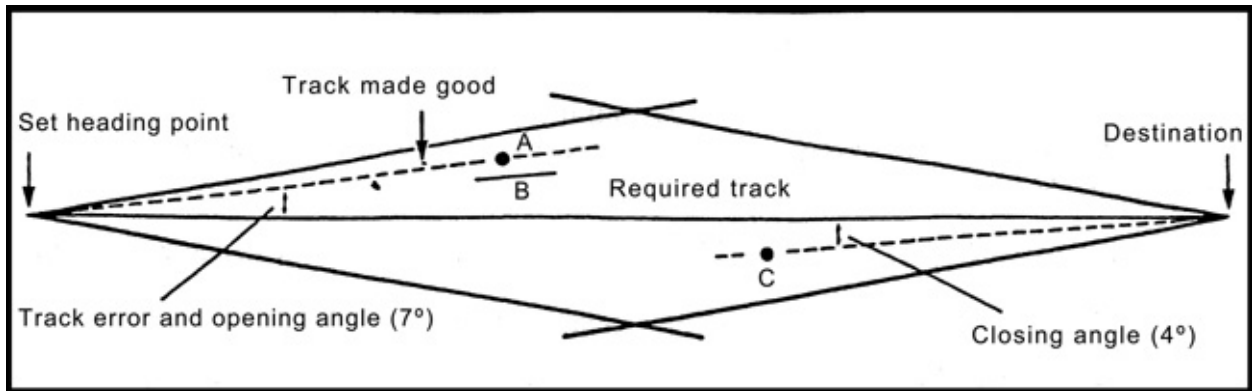

Figure 20-3: Track errors and opening and closing angles

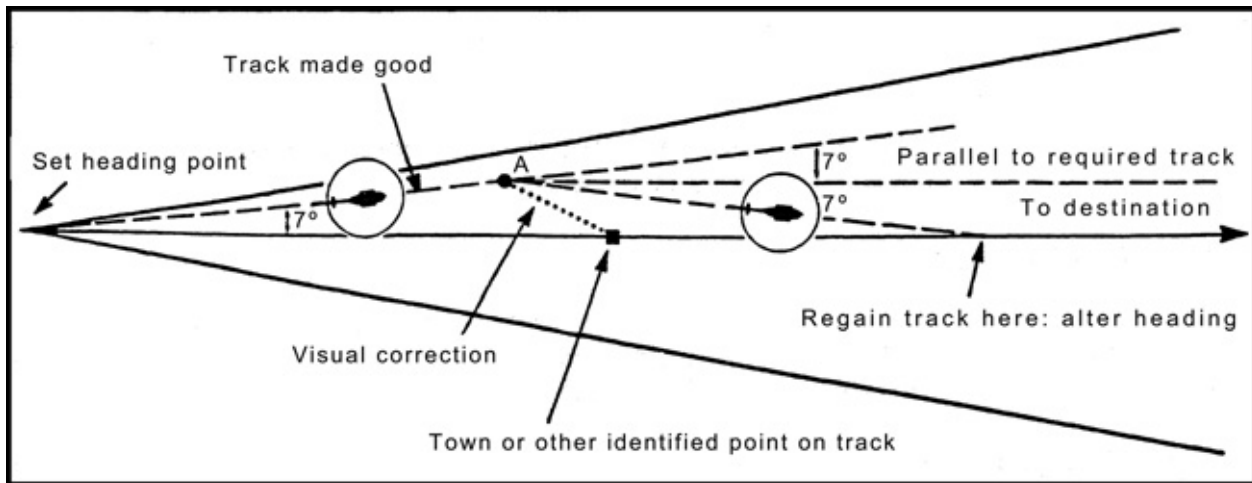

Figure 20-4: Double track error method

Heading Corrections

Once you have established the position of the aircraft accurately, and provided it is not on the required track, decide upon the best course of action. Normally, approximately 10 to 25 miles should be flown before attempting to estimate any track error, because errors over a short distance are magnified considerably. The heading of the aircraft can be changed so as to either return to the required track, or else fly directly to the destination. This will depend on the position of the aircraft. It is usually more desirable to return to the required track since the route study has been concentrated on that area and, in addition, a line already drawn on a chart is much easier to follow.

Provided the helicopter has not passed the halfway point, the double track error method or the visual alteration method can be used. If the helicopter is beyond the halfway point, you can still use the visual alteration method, or alternatively, the opening and closing angle method. Each method will be discussed in detail later in this text but first some basic geometry may help.

The key to understanding how these various methods work lies in the fact that if the helicopter heading is altered in the direction of the required track by a number of degrees equal to the track error or opening angle, the resulting heading will produce a track parallel to the required track. The desirable thing now is to get us back over track so that we can fly that heading. Some orderly method must be followed to take the aircraft from its present position off track to a point on the required track. Once this is accomplished we can then take up and fly the new corrected heading. Alternatively, we have the chance of flying direct from the position off track to the destination.

Using the 10-degree drift lines in Figure 20-4, it can be seen that the track made good is widening from the required track by an angle of 7 degrees. By altering the heading 7 degrees to the right, we now have the heading that produces a track parallel to the required track and is approximately the heading to steer when the required track is regained. (This is not strictly true, because in either method mentioned below the new heading calculated to keep the helicopter over track may not be exactly correct, due to the fact that the direction of the wind relative to the new heading is altered and drift may remain what it was before. Yet for most practical purposes the change of drift caused by such a small alteration in heading can be neglected.)

If you decide to return to the required track, the primary method is the double track error method. Simply double the amount of track error or opening angle, and apply this to the original heading in the direction of the required track: the helicopter will regain track in approximately the same period of time as it took to drift off track, and the required track will be intercepted again at a distance along track equal to twice the distance from the set heading point to the point when the heading change was made (Point A in Fig 20-3). On regaining track it is necessary to subtract half the correction applied to the original heading to obtain the heading to keep the aircraft on the required track.

If a positively identified landmark on the required track can be seen, the visual alteration method can be used. Once again the key fact is the heading change that would produce a track parallel to the required track. After determining the opening angle and applying it to the heading that produced the error, we now have a heading that we can fly once we are back on the required track. By simply flying visually from the present position (A in Fig 20-4) to the positively identified landmark, the new heading can now be flown and the helicopter should remain on the required track.

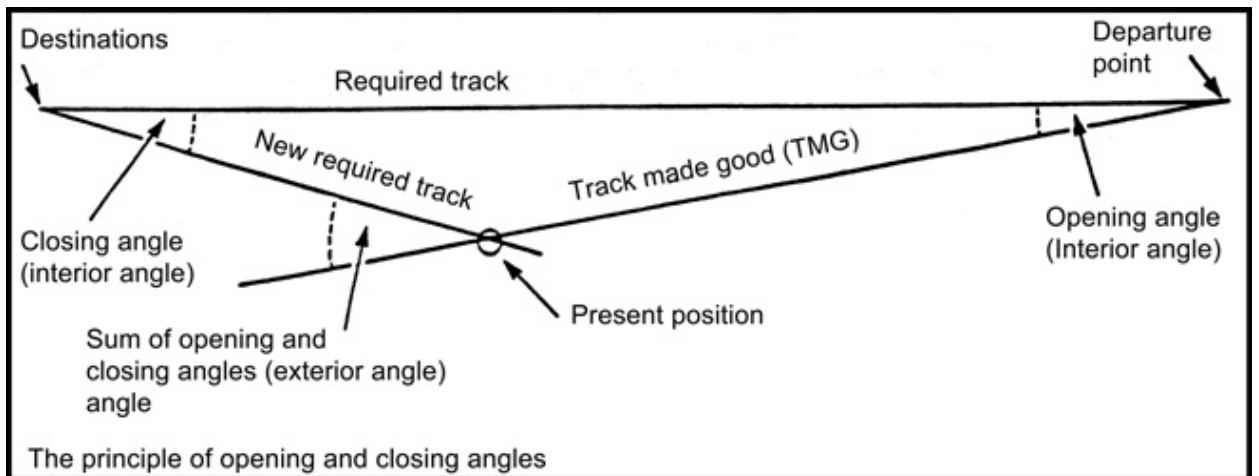
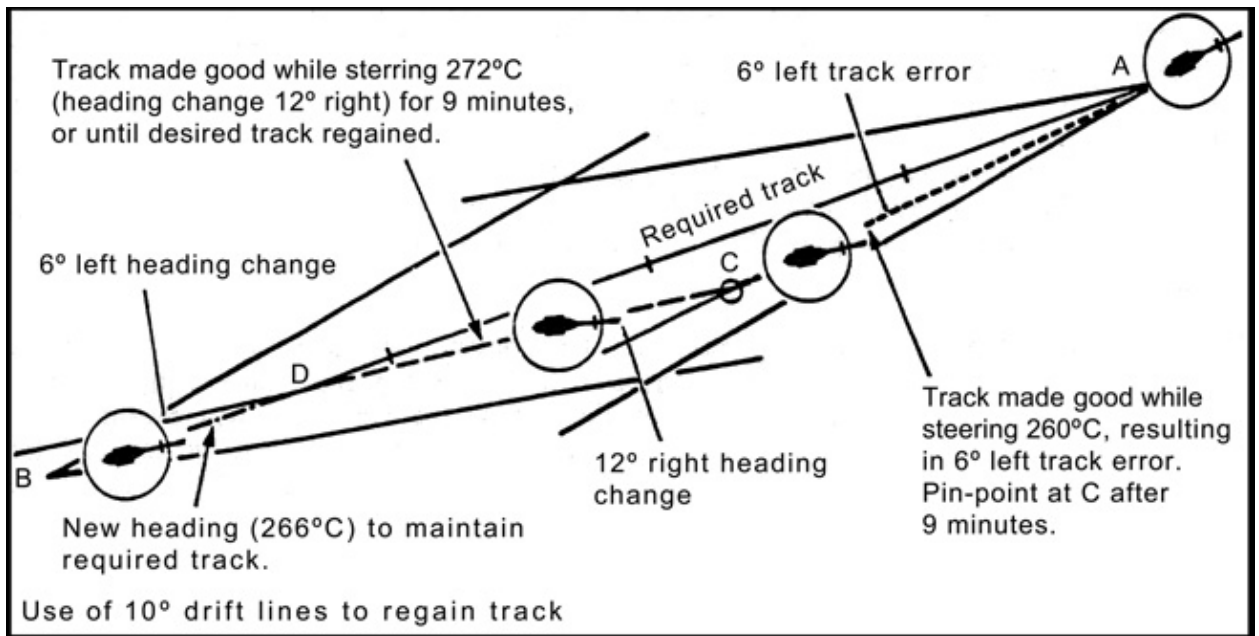
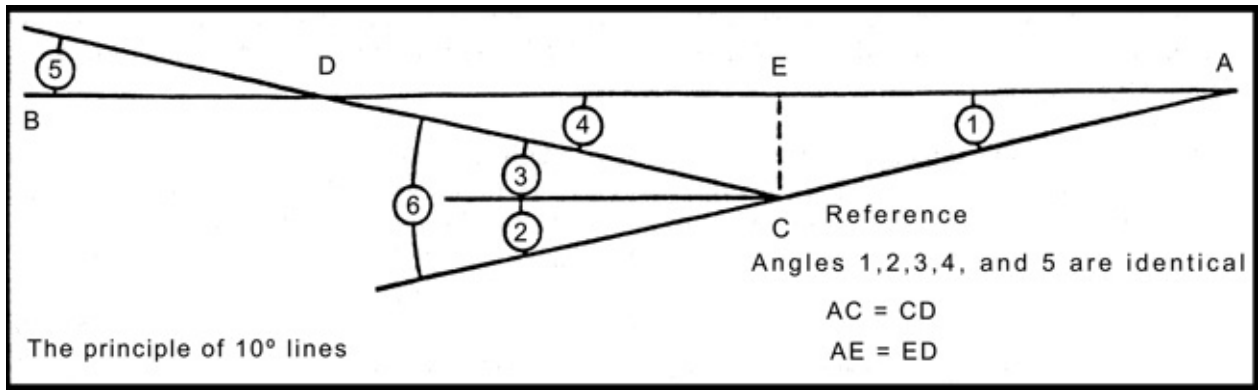

Figure 20-5: Methods of making track corrections

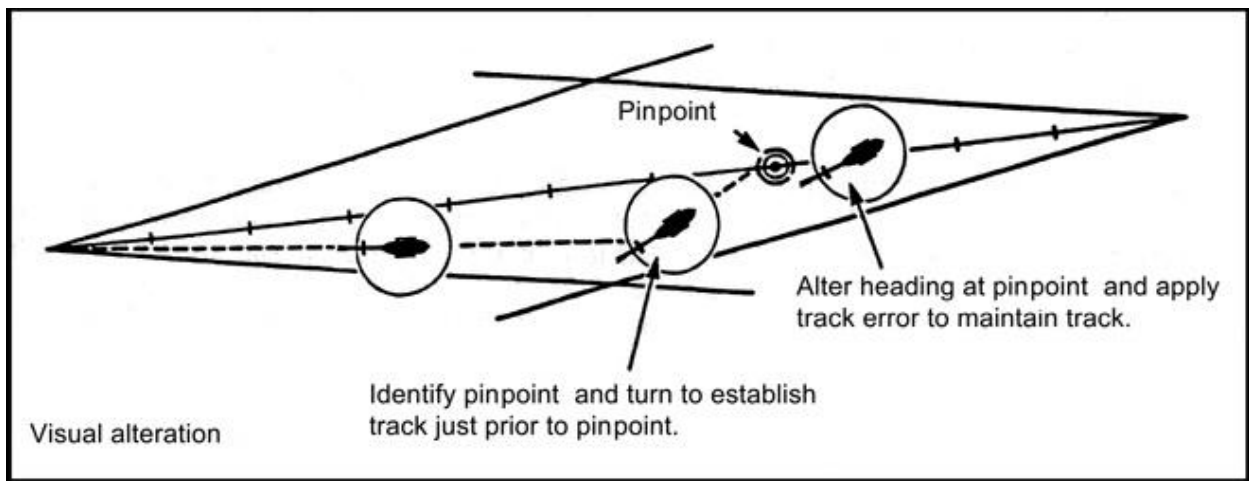
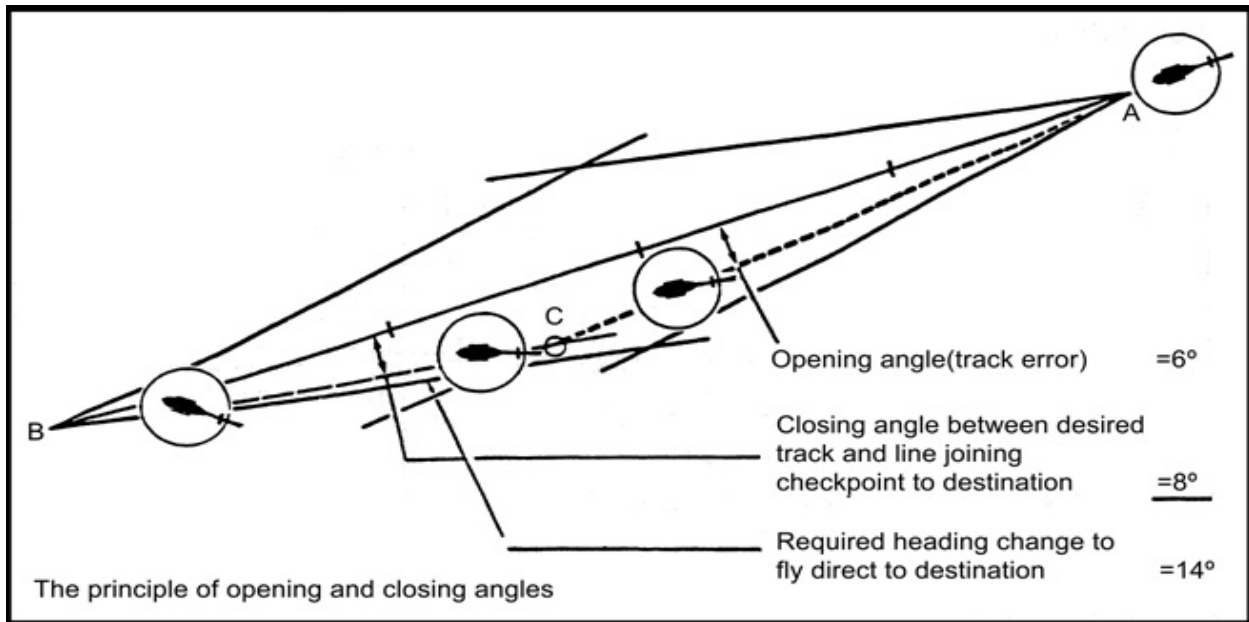

Figure 20-6: Opening and Closing angles/ visual alteration

Now let's look at a practical example of these two methods in Figure 20-7.

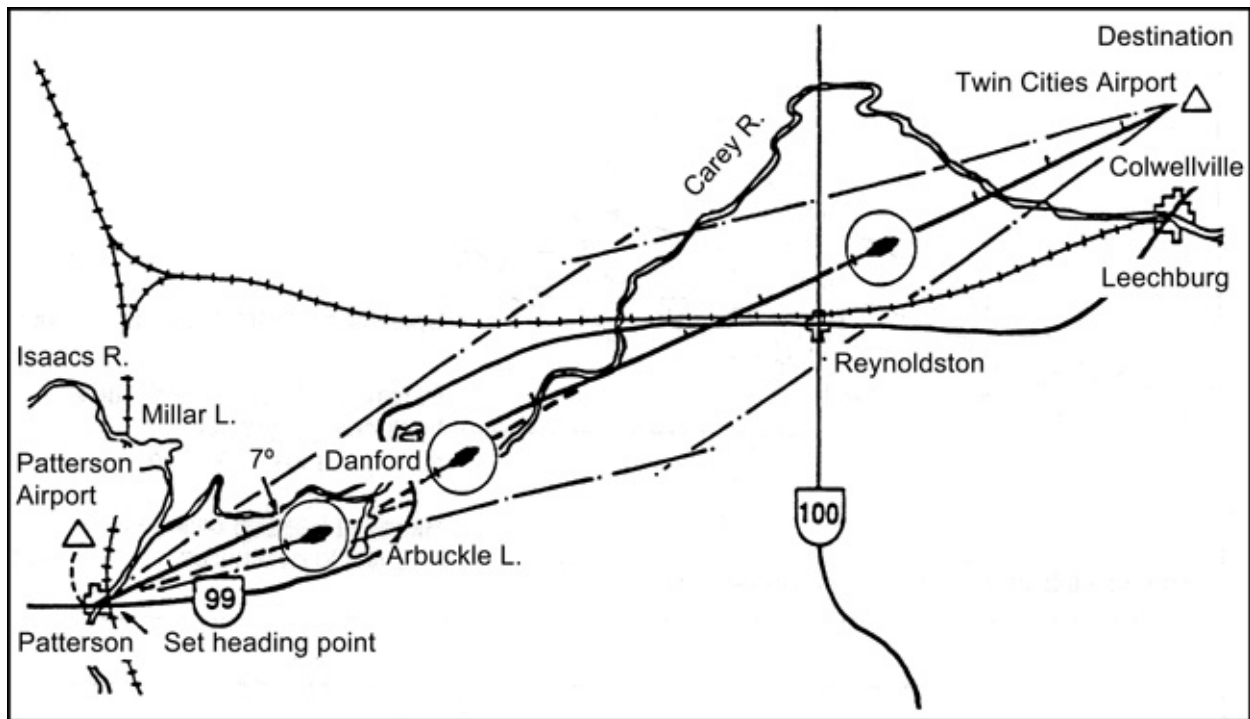

Figure 20-7: Tracking by double track error and visual alteration methods

We take off from Patterson Airport and set heading at 16:00 Z over the point where the railway line crosses the Isaacs River, at the town of Patterson. Our calculations have indicated that we must steer a compass heading of 065 degrees on our trip to Twin Cities Airport, 148 miles distant. After 14 minutes (16:14 Z) we pinpoint ourselves at the north end of Arbuckle Lake, and using the 10 degree drift lines determine that we are 7 degrees to right of track. A heading change of 7 degrees (058 degrees) left would result in a heading whereby we would parallel the required track. But as we wish to regain track using the double track error method, we alter heading to 051 degrees (065 degrees - 14 degrees = 051 degrees). This new heading is held for an additional 14 minutes and we regain track just south of the bend in the Carey River at 16:28 Z. At this time we alter heading 7 degrees right and steer 058 degrees. Any physical features near or along the track line, which will confirm that the track has been regained, will be helpful, but if none are available, the heading should be altered at the calculated time. Revised ETA can be made while flying towards the required track. If we had decided to use the visual alteration method, we could have flown visually to Danford, which is right on track and easily identifiable, and then steered 058 degrees (065 - 7 = 058) which should keep the helicopter on track.

Some flights are carried out over featureless terrain and may be more than half completed before a reliable pinpoint is located. This is where the opening and closing method can be used, or again the visual alteration method. As we have already discussed the visual alteration method, let's have a look at the principle behind the opening and closing method. Go back a few pages and study the definitions of opening angle and closing angle. By going back to basic geometry again and consulting Figure 20-5, it can be seen that by altering the heading by an amount equal to the sum of the opening and closing angles, we should track to destination.

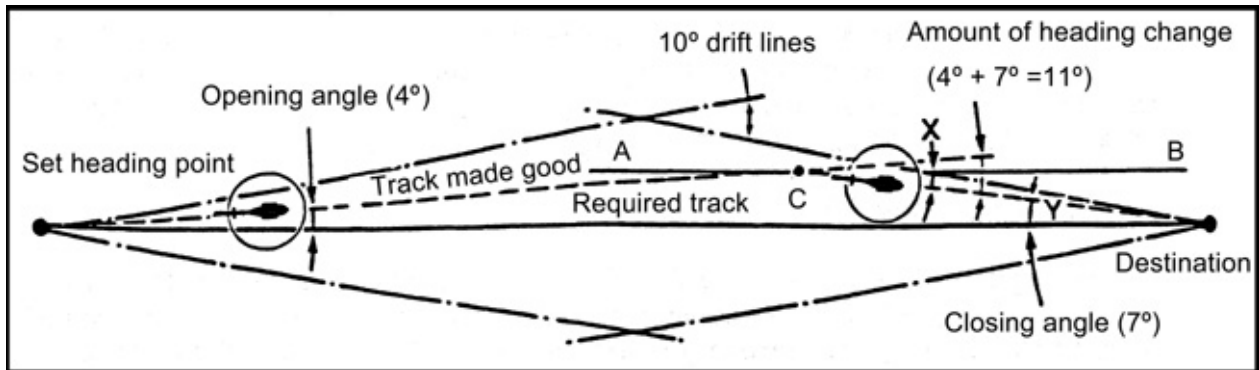

Figure 20-8: Tracking

In Figure 20-8 the line A-B passes through Point C where the heading change is made, and is parallel to the required track. At Point C, which is 4 degrees to left of track, a 4-degree right heading change would parallel the track. Angle X equals Angle Y (the closing angle) and using the 10 degrees drift lines we can determine that Angle Y equals 7 degrees. Therefore at Point C, an 11-degree right heading change (4 degrees + 7 degrees = 11 degrees) should permit the aircraft to track directly to destination.

Now let's look at a practical application. In Figure 20-9 the calculated heading to fly from Leech Airport to Carnegie Airport was found to be 105 degrees compass.

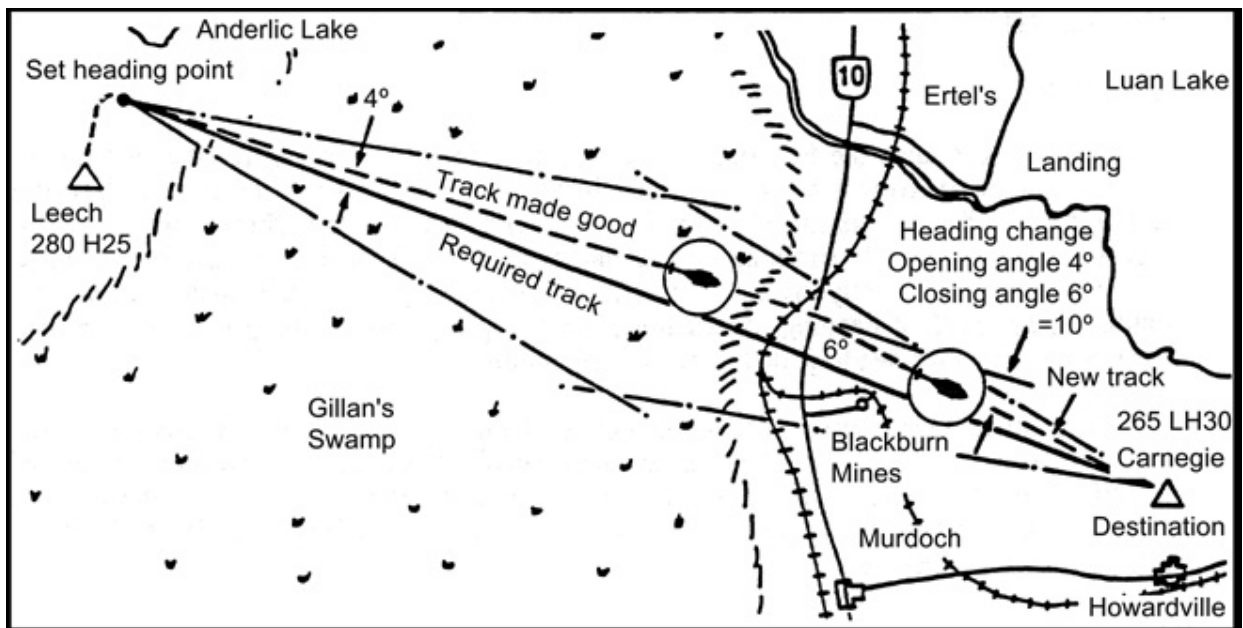

Figure 20-9: Tracking-a practical application

Set heading time was 15:00 Z. No reliable pinpoint was available until 45 minutes later, close to where the north-south railway crosses Highway 10, 82 miles along the track. Using the 10-degree drift lines we find the opening angle to be 4 degrees and the closing angle to be 6 degrees. Therefore, in order to fly direct to Carnegie Airport, a 10-degree right heading change (4 degrees + 6 degrees = 10 degrees) leads onto a heading of 115 degrees (105 + 10 degrees). As the ground speed is found to be 109 knots and there are 49 miles left to go, the revised ETA would be 16:12 Z. It should be understood at this time that the opening and closing method can be employed at any distance along the required track, and is not limited to use after passing the halfway point. Alternatively, a visual correction could have been made to the point where the original required track meets the curve in the railway line at Blackburn Mines, where a heading of 109 degrees (105 degrees + 4 degrees opening angle) taken at the time would have kept the helicopter on the track to Carnegie.

The Drift Compensation Method

Experienced pilots often establish heading by constantly compensating for drift as the flight progresses. When the heading to maintain a desired track is established by this method, drift angle can then be easily computed if you need it. Visibility must be such that enough checkpoints are visible to maintain an accurate track.

Select at least two prominent check-points a sufficient distance apart (5 to 10 miles or more, depending on the terrain), on the desired track ahead of the helicopter. Maintain a heading which keeps the nearer checkpoint aligned with the farther one. When the helicopter and the check-points remain on the same line, the heading indicated on the compass will be the heading which, provided there is no wind change, should keep the helicopter on the track required for the remainder of the flight. To continually compensate for wind effect, select another checkpoint on track in the distance before the nearer checkpoint is reached; then repeat the alignment and drift compensation procedure. Calculate ground speed by time and distance between checkpoints to keep ETA accurate.

THE FLIGHT

Setting Heading

After takeoff, establish the helicopter on the desired compass heading for the first leg, either over the heliport or over a convenient prominent checkpoint. Note the time and enter it in the flight log and calculate the ETA for the destination and the first checkpoint. Remember, to ensure accuracy in determining the actual amount of drift, it is necessary to begin the navigation exercise directly over the planned set-heading point. Immediately after you are established on the first heading, check the chart and pinpoints on the ground to confirm that the aircraft is in fact heading in the correct direction.

It is important to bear in mind that the objective of the pilot navigation cross-country exercise is to practise navigation by maintaining accurate headings, calculating and making corrections for drift, and calculating accurate ETA. Accurate map reading for exact determination of aircraft position is essential to provide the necessary information for calculation of heading and ETA corrections when required.

En route

Provided the set-heading procedure is properly completed, you can then concentrate on accurate flying, identifying checkpoints, and maintaining a good lookout. A prior knowledge of ETA over checkpoints along the route will allow you to anticipate and thereby identify them easily as the flight progresses. However, look out for other traffic must not be sacrificed to the navigation of the helicopter. Also perform normal in-flight checks at the prescribed intervals.

ETA Revisions

At the first positive pinpoint, ideally between 10 and 25 miles from the departure point, the ground speed should be calculated and ETA revised if necessary. Rely on the navigation instruments in the aircraft, rather than inexperienced personal judgement. It is most important to maintain a steady planned heading and airspeed. If you cannot at once recognize the track being made, do not suspect the compass of unreliable behaviour; continue to hold a steady heading until you reach a recognizable checkpoint. If a heading indicator is being used, check its heading frequently with the magnetic compass and reset it as necessary.

Checkpoints and Pinpoints

Time is one of the essentials of navigation, so acquire the habit of calculating ETA for en route checkpoints. This will help locate checkpoints by preventing the habit of looking for specific places on the ground too soon or too late. It is imperative that a reliable watch or clock be on board the helicopter during cross-country flights. The number of pinpoints on a leg varies according to the length of the leg. Usually one pinpoint every 10 minutes is sufficient, but more may be used if necessary. Once the aircraft has passed the pinpoint, immediately begin to anticipate the next checkpoint in the same manner as the previous one was anticipated.

Do not fly a zigzag path from check-point to check-point when the checkpoints can be readily identified from a position on or near the required track. There is no disgrace in not arriving directly over a check or turning point. Alteration in heading should be deliberate and aimed at flying in as straight a line as possible.

DIVERTING TO AN ALTERNATE DESTINATION

One of the skills required of the helicopter pilot is the ability to rapidly estimate a new heading to an alternate destination when, for various reasons, continuation of the flight is impracticable. Computation of headings, speeds, distances, and ETA in flight involves the same basic procedures as those used in pre-flight planning. However, because of space and time limitations and having to fly the helicopter simultaneously with computations, the pilot must take advantage of all possible short cuts. It is rarely practical to actually plot a line on a chart and mark checkpoints and distances as in pre-flight planning.

With a little practice, headings to alternates can be determined quickly with reasonable accuracy, by interpolation and mental transposition of airways and air routes on the chart or the azimuth information on the compass rose encircling VOR stations. These all have the advantage of already containing the magnetic variation for the general area. Use a pencil or the hand (on edge) as a straight edge. If airways or a compass rose are not close enough on the chart to be used, an angle may be estimated as being a fraction of the 90-degree angle between the meridians of longitude and parallels of latitude found on the chart. If possible, draw a line freehand on the chart from the divert point to the alternate destination.

Distances can be estimated accurately enough for diversion purposes by using the thumb and index finger as "dividers" applied against the scale on the chart, or easier still, against the mileage lines that were marked along the original track before the flight began. The compass rose circles around VOR stations are all 35 statute (30 nautical) miles approximately in diameter on Canadian 1:500,000 aeronautical charts.

When diversion to an alternate destination becomes necessary, the decision to change to a new heading should be made as early as possible. First, consider the distances to all available and suitable alternates, select the one most appropriate and then estimate the heading to the alternate chosen. Turn the aircraft to the new heading and then, more accurately, estimate drift correction, distance, speed, compass heading, and ETA while proceeding towards the alternate. Under the circumstances, it may be advantageous to “hold” over a known checkpoint while computations are made.

If a suitable choice is available, always divert to the spot that offers the easiest route to follow, such as a highway, river, power line, etc. This is particularly important if visibility is a factor. If low-level navigation is required due to low ceilings keep a careful lookout for obstructions. Diversion is often synonymous with emergency; this is not time to test your pure navigation skills if you don't have to.

To compensate for the wind, which can often be an unknown factor in diverting to an unplanned alternate, establishing a heading by means of drift compensation may be the best expedient. The forward landmarks should be readily identifiable and, if visibility is a factor, they should also be reasonably close to the desired track. Again, rely on the instrument indications and any new heading established by drift compensation will be fairly close to the heading originally estimated for the diversion track.

In-Flight Mental Calculations

Mental arithmetic can be sometimes difficult when flying, and you may add to the following suggestions as your experience increases. When the distance and time is known, finding the ground speed is much easier if the “time” part is a fraction of 60 minutes. 25 NM covered in 12 minutes is 125 kts. We know that 12 minutes multiplied by 5 equals 60; thus, by multiplying the distance covered by 5, the ground speed can be easily determined. Another example is: 40 NM covered in 20 minutes is 120 kts (40×3). If a distance marker on a track line coincides with a checkpoint, the time at the distance marker twice the distance away will be twice the elapsed time.

If You Are Uncertain of Your Position

The danger of jumping to the wrong conclusion is very real when you cannot recognize expected landmarks. There are times when you will be uncertain of your position. Such moments require calm reasoning and a recognized procedure. The recognized procedure is as follows:

1. if you can, identify your last known position on the map;
2. hold a steady heading and check the heading indicator against the compass;
3. start reading “ground to map”;
4. climb, if possible; the higher you are the more ground you can see;
5. check all previous calculations by studying your chart and log;
6. draw a circle of uncertainty;
7. check for a possible wind shift;
8. try to get a bearing using radio aids; and
9. if all else fails find a suitable area and land until you sort out the problem.

Usually you can establish your position within a short time and continue the flight. You must never assume, however, that you are in a certain position. Check for a possible shift in the wind by drawing a circle of uncertainty.

To do this, draw a circle on the chart around the position you would be in if you were on track and on time. The radius of the circle should be 10 per cent of the estimated distance flown since the last confirmed position. Checks within the circle of uncertainty for any prominent physical features you have noted on the ground, and when you have positively identified one or more landmarks, fix your position. Remember, positive identification of a distinctive landmark is the only way to get back on track. If you decide that you are definitely lost, LAND. Do not exhaust your fuel in aimless wandering from one heading to another trying to pick up a landmark. You can usually find a landing spot, you burn a lot less fuel, and tend to think a lot more calmly and rationally when you are sitting on the ground. Always work to plan. Notify ATC by radio that you are lost, or try to contact any other aircraft or control agency. When you have established radio contact, transmit your general position, the amount of fuel remaining in the tanks, ask for whatever assistance you need, and indicate the action you propose to take.

Usually you will have a rough idea of the direction of home base and can turn towards it, while continuing to search for prominent landmarks. "DF steers" are available from ATC in many areas and provided you are within radio range a heading to fly will be freely offered. Do not be too proud or afraid to ask for assistance.

If you have no idea of the direction to fly, set up a triangular pattern at endurance speed settings, at the highest practical altitude, to alert the radar network. If shortage of fuel becomes a problem, land to conserve remaining fuel.

In an extreme emergency, if there is absolutely nowhere to land, you should broadcast a MAYDAY distress message on 121.5 MHz giving the helicopter type, the nature of the emergency, the amount of fuel left, the assistance required, and your immediate intentions. Listen out on the same frequency for instructions.

Pilot Navigation

One advantage of the helicopter over other aircraft is its ability to land in unimproved locations. Do not exhaust your fuel supply by continuing to fly; select a suitable field near habitation if possible, and land preserving sufficient fuel to return to base. A thorough map study on the ground may re-orientate you, but do not take off again if you are still unable to positively fix your location.

Reciprocal Track

For one reason or another, such as a diversion to an alternate, it may be necessary to calculate a track to take you over the route you have just flown. An easy method for mentally calculating the reciprocal of a heading is to add 200 to headings less than 180 degrees and then subtract 20. For headings of more than 180 degrees subtract 200 and then add 20.

Once on the reciprocal track, the allowance for wind will be opposite to that used outbound. If 10 degrees was added to the outbound track to allow for drift, it will now be subtracted from the reciprocal track to obtain a compass heading. This heading should be adequate until a new and more accurate one is calculated. Turn the chart 180 degrees, map read back to a known fix, and then resume normal navigation either back to the point of departure or to an alternate destination.

Low Level Navigation

There may be an occasion, during a cross-country flight, that will necessitate low-level navigation. Some of the flying on your flight test may also be done at low level. Special mention is therefore made now of low-level map reading.

The greatest difference in navigating at cross-country altitudes lower than usual is the restricted field of view at low level, which becomes extremely limited when flying over rough or hilly terrain. This, combined with the greater attention that must be given to handling the helicopter, cuts down the time you have to positively identify your landmarks and checkpoints as they come up. Since you cannot hope to continually compare your checkpoints with the chart to assist identification, you must pick unique, easily recognizable features. Line features, such as railway lines or roads, that run 90 degrees to the track are used as check-points, and those that run to the turning point are used as lead-in lines.

During low-level navigation flight, you have to be on the lookout for obstacles such as TV and radio antennas, power lines, factory chimneys, and sharply rising ground. The set-heading procedure should be carried out if possible, before descending to the low-level altitude, and navigation should be strictly confined to map reading. Log keeping is impossible because of the urgent need to keep a good lookout. Check outside frequently if altitude is critical, to avoid flying into the ground. If you become uncertain of your position, if possible climb as high as necessary to give yourself an extended field of view and try to identify a landmark.

Remember that when you are doing cockpit checks you must not bury your head in the cockpit. Complete the first item and then pause to have a thorough look around; complete the next item and look around again; continue in this way until the check has been fully covered.

If your low-level navigation technique is to be a success, you must develop good handling habits, so that most of your time can be devoted to checking your position and to look out.

The Magnetic Compass' errors

Under some conditions of flight, this instrument can react in wild motion.

The mechanical and other reasons for the eccentric behaviour of this instrument will not be discussed here. What is important to know at this time is that the magnetic compass can be relied on only when the helicopter is flying straight, and at a constant airspeed.

When a helicopter on a northerly heading executes a turn, the compass card remains stationary on its pivot or momentarily turns in the opposite direction. This falsely indicates less than the real amount of turn. The compass may be said to lag in turns from a northerly heading.

When a helicopter on a southerly heading executes a turn, the compass card turns faster than the helicopter, instead of remaining stationary on its pivot. This falsely indicates more than the real amount of turn. The compass may be said to lead in turns from a southerly heading.

When a helicopter is maintaining an easterly or westerly heading, changes of speed will cause the compass to falsely indicate a turn, deceleration will indicate a turn to the south and acceleration will indicate a turn to the north.

Weather

Weather conditions should be constantly observed during a cross-country flight. Any sign of deteriorating weather must be seriously assessed and appropriate action taken without delay to keep well clear of it. When you encounter or are about to encounter bad weather, avoid haphazard changes of heading looking for a path through it, as this may disorient you. The navigation exercise then breaks down into a confused search for a way out of the weather. If any doubt exists concerning the weather ahead, to avoid it and keep the navigation of the helicopter intact, turn the helicopter completely around and fly the reciprocal of the original required track. Do this by making a standard rate turn through 180 degrees, which should take one minute if the turn is being timed.

Remember that you are flying a helicopter. Unless you are over extremely inhospitable terrain you can normally find a suitable area and land until the weather moderates.

Common Sense

Pilot navigation requires the application of common sense. For example, such things as the sun, rivers, lakes, the location of prominent landmarks, etc can verify approximate direction. When en route, communicate briefly with as many ground stations as reasonably possible.

It is sound practise to let flight progress be known and it is always good insurance to have the current weather for the destination and intermediate points, which may be provided by some ground stations. When the flight is apparently going well, do not be lulled into a sense of false security and abandon map reading for long intervals. Continually take mental note of areas on the route that would be suitable for emergency landings. Should something occur which appears to affect the safety of the flight, evaluate the situation carefully; the most prudent action may be to land at the first opportunity.

Do not hold charts or other pilot navigation material too near open windows, as there is a strong suction at such points that can easily snatch light articles out of a helicopter in flight. At last, make sure that more than one pen or pencil is available.

EXERCISE 21 - RAPID DECELERATIONS

“A helicopter is operating low level in restricted visibility; the pilot has reduced speed to 60 mph because of the weather. While flying in a narrow valley, high tension cables appear rapidly out of the gloom.” This situation is an all too-often occurrence, so what can you do? Correct! — a rapid deceleration, or quick stop, as it is sometimes called. The above example is one use for a quick stop; another is as a means for developing co-ordination and accuracy.

The purpose of a rapid deceleration is to stop the aircraft rapidly. There are two main variations: the into-wind and the downwind stop, obviously if you are crosswind a partial turn into wind is utilized. The downwind or 180° emergency turn entails turning the helicopter back into the wind during the stop, avoiding the dangers of a low airspeed while facing downwind.

INTO WIND

Fly the helicopter straight and level, at 70mph and 50 feet AGL, as you run in choose a heading reference in the distance (Fig 21-1). Give a verbal warning “Practice quick stop, go”, on the executive word “go” proceed as follows:

1. commence a gentle flare by easing back on cyclic, at the same time lower collective to maintain height, apply right pedal to maintain heading;
2. as the flare starts to lose effect gently raise the collective to maintain height, as the groundspeed approaches zero select the hover attitude with cyclic, then continue to apply power to establish the hover at 50 feet AGL;
3. keep your heading throughout and avoid over-controlling with the pedals;
4. once you have established the hover, move the helicopter forward and down to normal hover height; and
5. maintain RPM throughout with throttle if required by type.

The gentle flare is to help you to become proficient at the exercise and smooth coordination of the controls. Once you have mastered it, the manoeuvre can be speeded up to achieve the necessary stopping distance. The larger the flare, the greater will be the tendency to climb, leading to larger control movements overall and greater difficulties with control coordination.

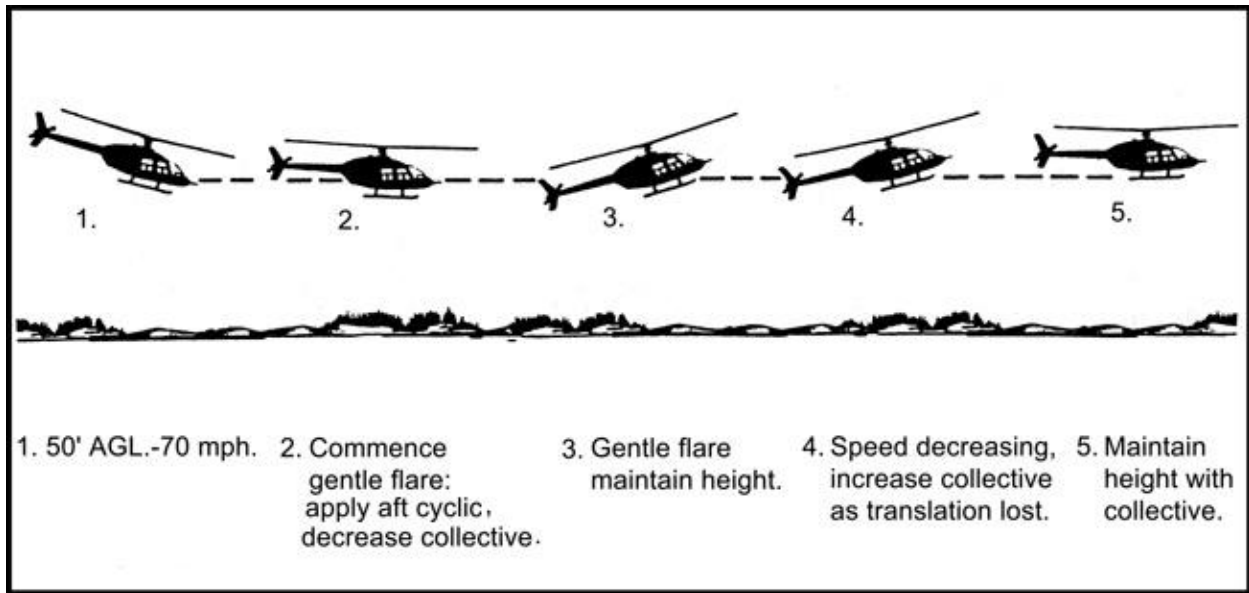

Figure 21-1: Quick stop into wind

Your instructor will show you that if you flare too harshly the needles could split, and how to recover from this situation. Be sure to anticipate with collective before losing translational lift, to stop any tendency to sink, otherwise you could be setting up the conditions necessary for vortex ring.

DOWNWIND (180° EMERGENCY TURN)

Fly the helicopter straight and level, at 70 mph airspeed, 50 feet AGL.

1. Commence a level co-ordinated turn using approximately 30 degrees of bank, ease back on cyclic to initiate a gentle flare, maintain height with collective and balance with pedals;
2. your rate of turn will increase as your airspeed decreases; you must maintain at least 30 mph until the nose is within 30 degrees of the wind to avoid any problem when heading out of wind at low airspeed;
3. during the last 30 degrees of turn adjust your angle of bank to roll out heading into the wind, at the same time adjusting the flare to reduce the groundspeed to zero;
4. as your ground speed approaches zero increase power and establish the hover as before into wind at 50 feet AGL, then move forward and down to normal hover height; and
5. Prevent yaw with pedals, maintain RPM throughout with throttle if appropriate to type.

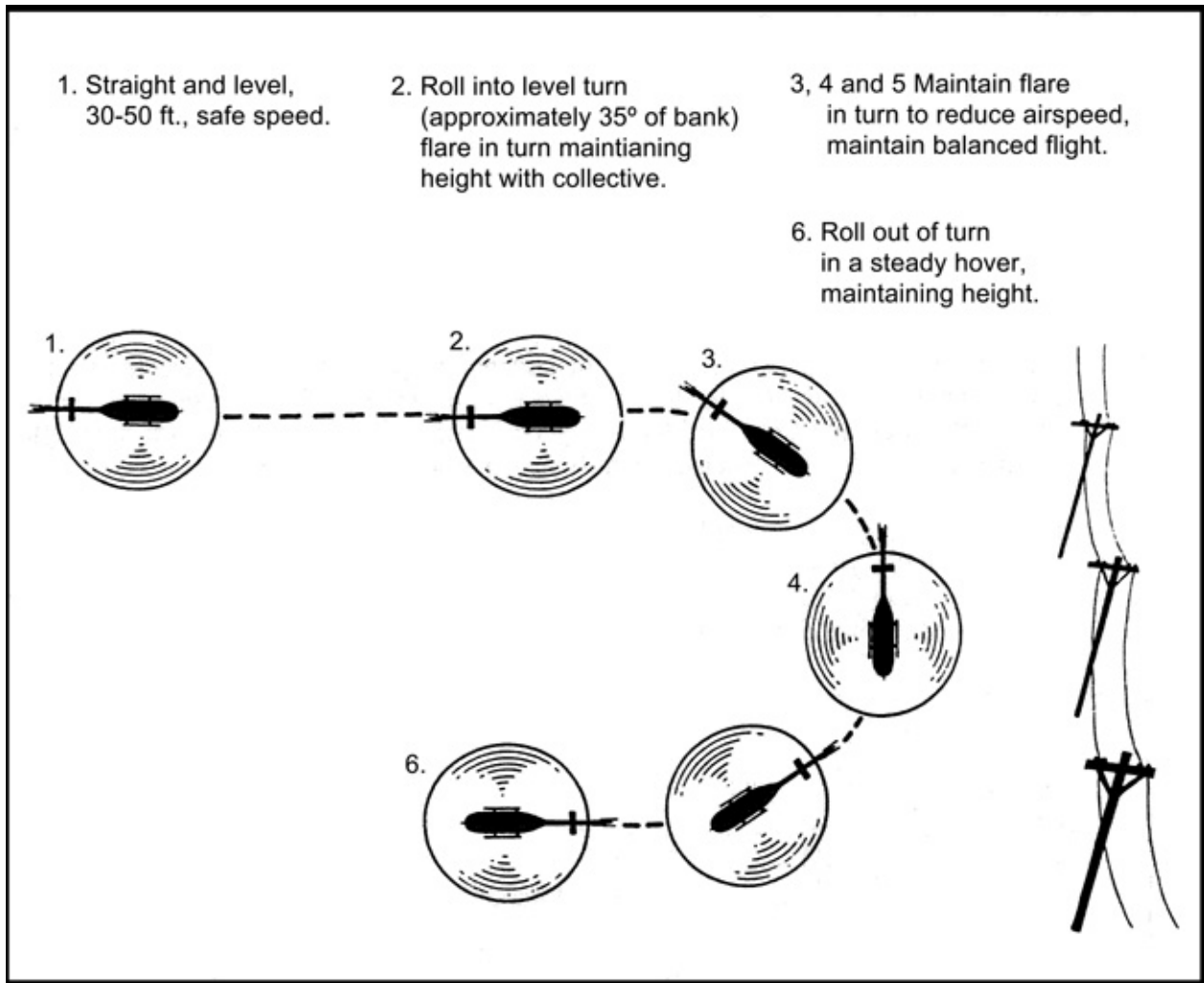

Figure 21-3: Obstacle

The handling of the helicopter should be with small, smooth control movements, as this exercise requires a high degree of coordination and accuracy.

EXERCISE 22 - LOW LEVEL OPERATIONS

The helicopter is a very versatile machine. Because of this, it is called upon to do many varied tasks. More and more uses are being found, and as the number of tasks increases, the number involving low level operations increases. The following examples are all flown low level: pipeline, hydro-line, beaver, moose and deer survey. There are numerous other jobs, most are of the reconnaissance variety and all are very demanding because of proximity of the ground and the dangers associated with flying close to the ground.

Considerations

A. **Navigation.**

As you have no doubt discovered in practising cross-country techniques, the lower you fly, the harder it is to map read because of the reduced area visible and the shorter time available for identifying landmarks. To try and navigate a straight line is virtually impossible because of hills or obstacles on your track.

1. Wires: While flying low level your lookout cannot be relaxed for more than an instant, as many of these lines are extremely difficult to see, especially across valleys and in differing light conditions.

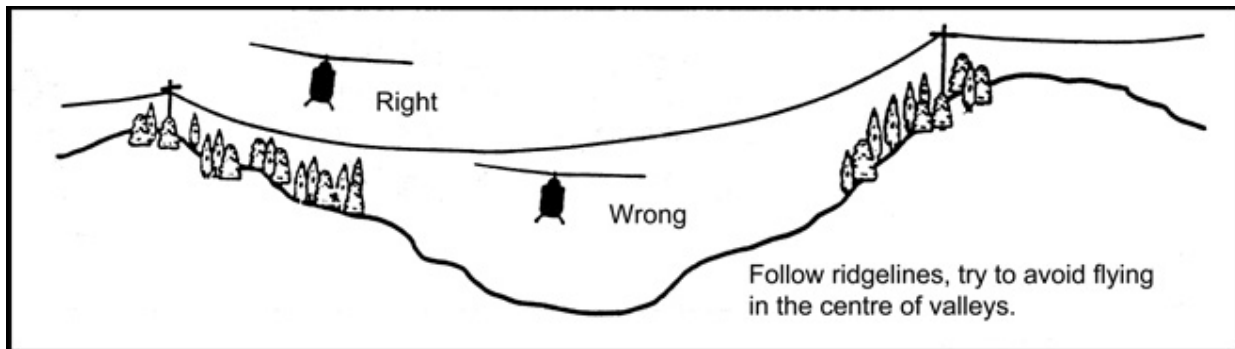

Figure 22-1: Low Level Operations-Wires

If you are about to fly low level with someone else on board brief him or her to say “Wires” as soon as they are seen. The pilot-in-command should reply either “Contact” or “No Contact” to confirm the sighting. Similarly, the pilot should comply with the above rule.

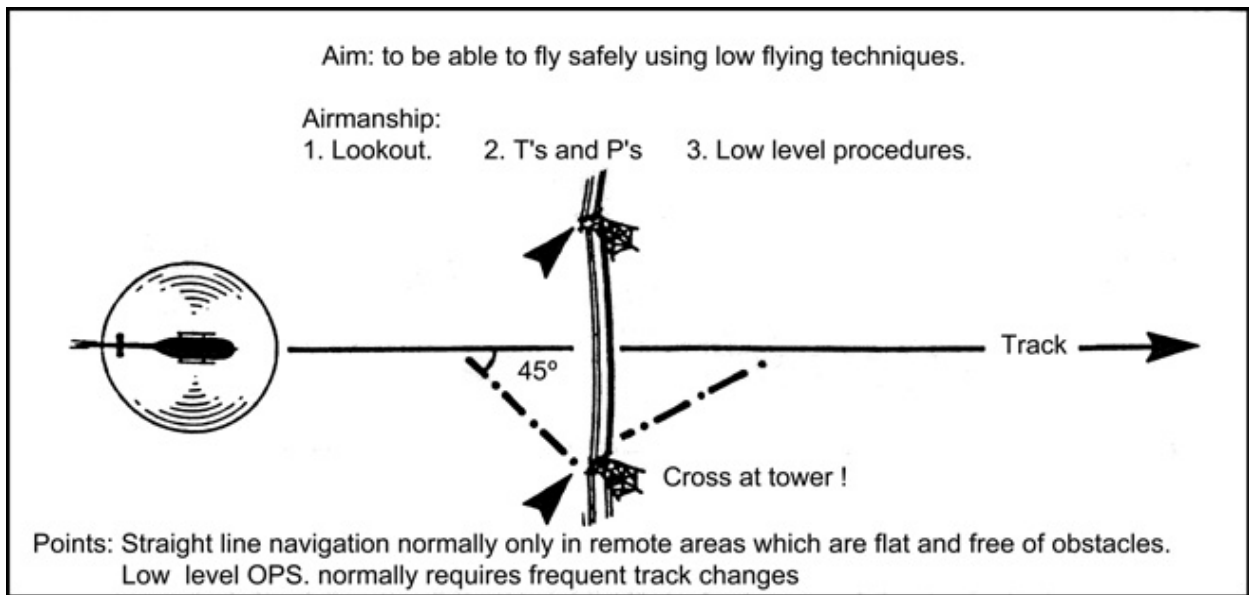

Figure 22-2: Low Level Operations-Wires

Wire lines should be crossed at an angle of 45 degrees to give the pilot a choice of turning away from the line or going over the line in case of emergency.

2. Minimum altitudes and distances: Built-up areas and livestock are to be avoided when flying low level. In most cases, flying over these sensitive areas are illegal and dangerous.

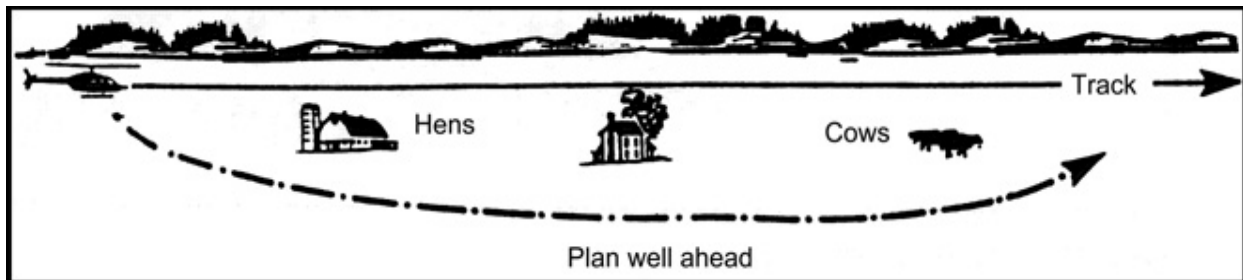

Figure 22-3: Low Level Operations-Houses and livestock

3. Low-level flight over the trees: they give little or no choice for you to make an emergency landing. If there are clear areas, try to choose the best flight path with regard to your route

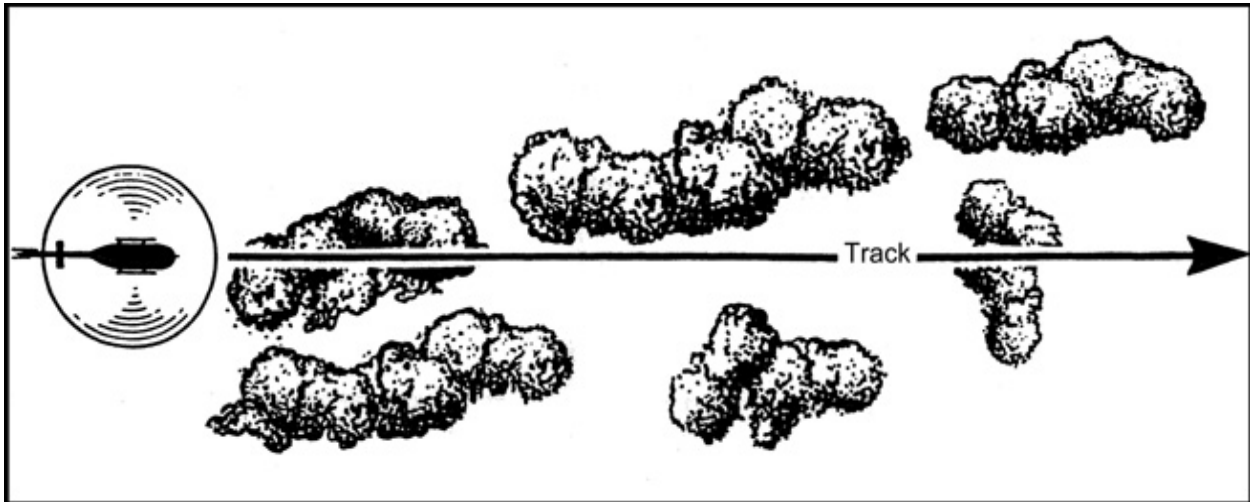

Figure 22-4: Low Level Operations-Trees

4. High ground: Rising or high ground can also cause you to deviate from your track. Try when flying towards high ground to approach at an angle of less than 90 degrees, turning away should be easier in the event of emergency.

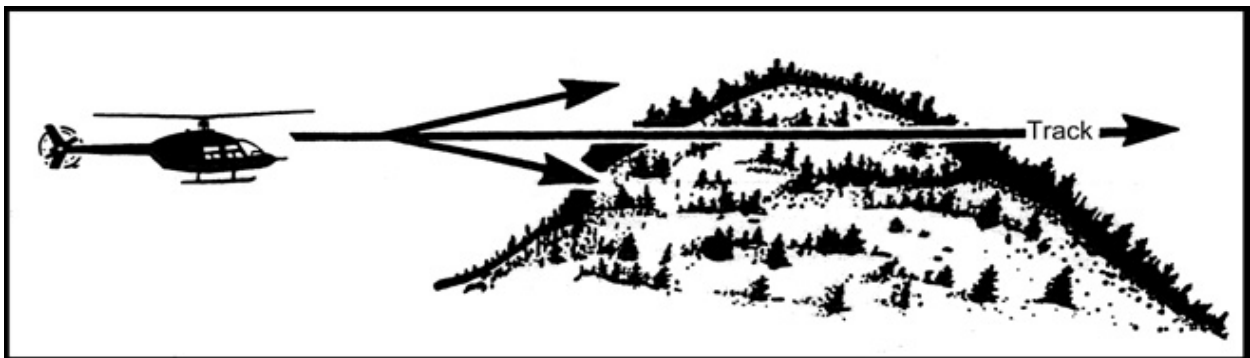

Figure 22-5: Low Level Operations-High Ground

B. **High Winds.**

1. Groundspeed when flying at lower elevations is much more apparent than at altitude. This could give you the impression, when downwind, of a much higher airspeed. If you then further reduce airspeed it will be almost impossible to turn into wind in case of engine failure. Directional control becomes progressively worse as you reduce airspeed. When operating near to maximum weight and high-density altitudes, always maintain a safe airspeed because of the inherent danger of setting up the conditions for vortex ring.
2. Turning upwind to downwind makes you believe that the helicopter is slipping inwards. This is an illusion, but the drift is real, and room must be allowed to clear obstacles on the inside of the turn. Conversely downwind to upwind creates the opposite effect. A point to remember is the lower the airspeed the greater the illusion of skid and slip with a given wind velocity.
3. As a rule, mechanical turbulence increases as altitude decreases.

C. **Communications.**

Radio performance deteriorates the lower you fly, particularly line of sight systems including navigation aids.

D. **Emergencies.**

Your instructor will show you the techniques to employ should an emergency occur at low level. Be aware of the «avoid» areas of the Height Velocity chart.

Usually low-level flying is not practised solo. All flying organizations have rules that must be adhered to with regard to height and suitability of local training areas.

EXERCISE 23 - SLOPING GROUND

Helicopters are often called upon to land on unprepared, sloping terrain; indeed it is sometimes very difficult to determine the existence of a slope until the moment of landing. Therefore, as a helicopter pilot, you must be capable of landing your aircraft on terrain that is sloping or has a doubtful surface. The techniques you will learn in this lesson are also suitable for use when faced with a landing on muskeg, packed snow, or any uncertain surface.

Prior to commencing your landing, ensure that you have made a good reconnaissance of the area for obstacles that could pose a hazard to the tail rotor as you manoeuvre, or that could snag the skids and cause a rollover accident. You must also carefully consider the wind velocity, as this may be a limiting factor in the conduct of the manoeuvre. For example, it might be very difficult or sometime dangerous to carry out slope landings with the tail pointing into wind because of control difficulties. Prior to commencing this exercise, you must also review the helicopter flight manual limitations section, as most light helicopters have maximum allowable slope landing limits published. However, lateral slope of 5 or 6 degrees is considered acceptable for most of helicopters.

Sloping ground operations can be divided into four phases as follows:

1. Reconnaissance
2. Manoeuvring
3. Landing
4. Takeoff

RECONNAISSANCE

During any landing or takeoff, the pilot makes a reconnaissance of the area. Should the chosen area likely have a soft or slippery surface, or if obstacles exist, then extra care must be taken to ensure that landings and takeoffs can be conducted safely. This is also the case with sloping ground.

Remember that the helicopter hangs one skid low in a steady hover. You can use this information to determine which skid to place uphill, as it will be easier to land on the slope in this manner. Your ability to conduct cross-slope landings will also be determined by cyclic limitations; there may be insufficient cyclic travel available to you to land the helicopter.

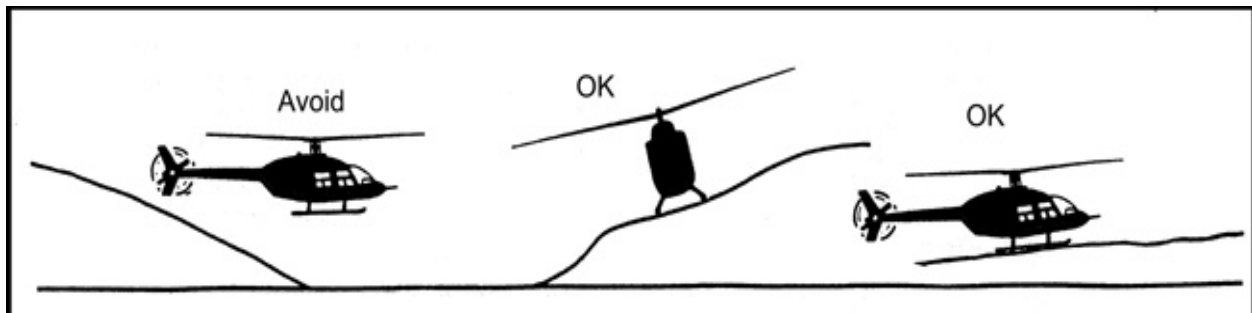

Figure 23-1: Landing-Uneven Terrain

It is desirable to land into the wind whenever possible, but there will be times when you have to compromise on the wind direction. Similarly, you may have to compromise on the slope of the ground to carry out the landing. It is very important to make a thorough reconnaissance of the selected area before you attempt the landing.

MANOEUVRING

During sloping ground operations, the tail rotor is extremely vulnerable. You must remember that the tail rotor is some distance behind you, and care must be exercised when manoeuvring to ensure that you do not strike the tail rotor on any obstacles, or the slope itself. This is especially so when performing hovering turns and when landing either upslope or downslope. When you are required to turn in close proximity to the slope, always turn the tail away from the slope. Using this procedure will lessen the chance of a tail rotor strike.

LANDING

In preparation for the landing you must establish a steady hover over the selected spot (Figure 23-2). Gently begin to lower the collective, allowing the helicopter to settle until the uphill skid contacts the slope. Pause slightly. Now as you further lower the collective, you must also progressively move the cyclic towards the slope keeping the rotor-disc parallel to the horizon. This will prevent the helicopter from sliding down the slope. It is possible to exceed the limits of cyclic travel at this point, or you may find that the helicopter begins to slide. Should this occur, smoothly lift the helicopter into a hover clear of the slope and select another landing spot. If sufficient cyclic control remains, continue to lower the collective until the downslope skid contacts the ground. Throughout the landing manoeuvre, ensure that you prevent yaw with use of pedals. Once on the ground, carry out a "seating check" by making small and gentle movements of both pedals and collective. Do not centre the cyclic, or roll back the throttle, until you have performed the seating check and you are satisfied that the helicopter is not going to slide. Under some conditions (e.g. dropping off passengers and leaving) it may not be desirable to centre the cyclic or carry out the seating check, nor roll back the throttle.

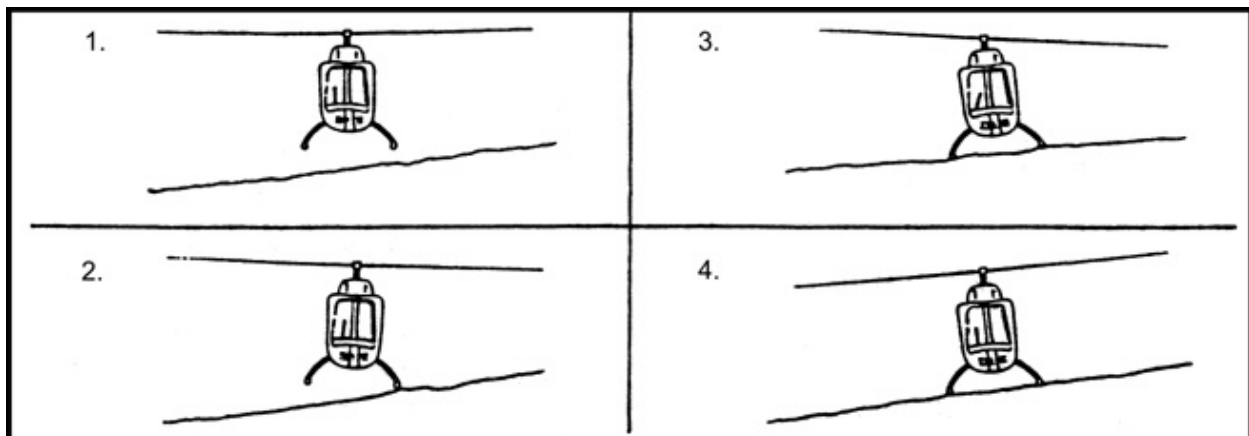

Figure 23-2: Landing-Uneven Terrain

It is most important that your control movements are smooth and accurate, and that you avoid any tendency to over control as it is possible to set up a roll rate, especially about the skid in contact with the slope, which could then lead to dynamic rollover that opposite cyclic could not counteract.

TAKEOFF

In preparation for the takeoff, carry out the pre-takeoff checks, and ensure that the rotor RPM is correctly set. Before beginning to gently raise the collective, level the rotor-disc, so that it is once again parallel to the horizon. The downslope skid will begin to rise; in the reverse of the landing sequence (fig 23-2), the cyclic must now be progressively moved away from the slope as the collective is being raised. Coordinate the movements of the two controls, so that the helicopter smoothly breaks contact with the ground and rises vertically into the air. Maintain direction with the pedals and ensure that all lateral movement is eliminated, avoiding the possibility of a dynamic rollover situation.

GENERAL

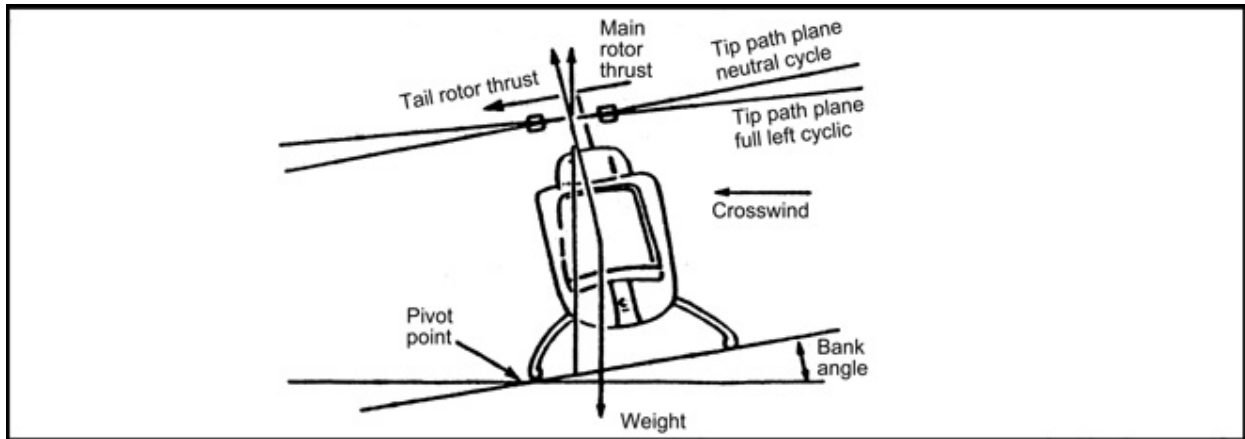

Figure 23-3: Dynamic Rollover

Your instructor will review with you the conditions that could lead to dynamic rollover and the avoidance techniques. It is important that your helicopter has been properly loaded and is within CG limits, both laterally and longitudinally, as an out-of-limits helicopter could lead to a situation favourable to dynamic rollover. For similar reasons, the importance of smooth, gentle control movements while ensuring that the skids are clear of snags and obstacles, and the importance of maintaining RPM at maximum will be stressed.

It is possible to exceed the cyclic control limits when performing slope landings. When moving the cyclic towards the slope you may:

1. feel the cyclic physically restricted from further travel; or
2. encounter mast bumping or droop stop pounding. This will manifest itself through a thumping noise at the rotor head and vibrations.

Do not continue to attempt to land under these circumstances, but lift off again to the hover.

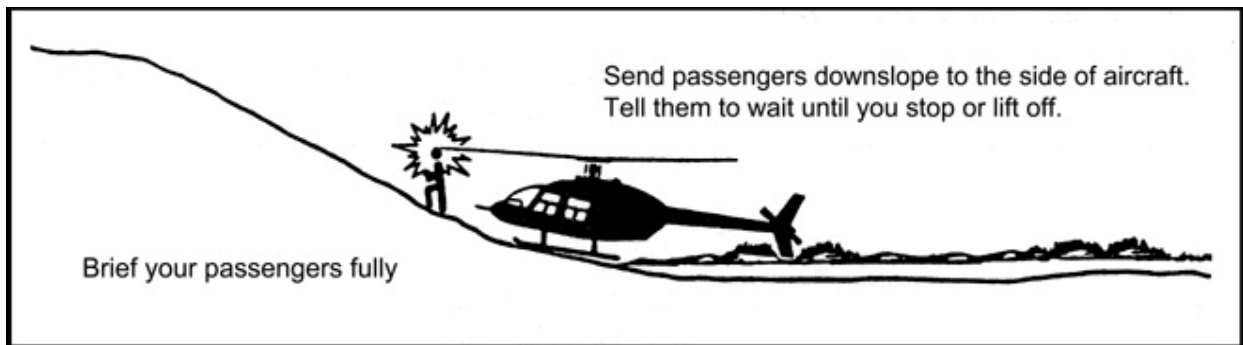

Figure 23-4: Disembarking Passengers

Your instructor will discuss with you the potential hazards of embarking or disembarking passengers while the helicopter is on a slope. The rotor blades are very close to the ground on the uphill side and present a real hazard to passengers. Brief your passengers of the direction to take and remain within your view the whole time.

EXERCISE 24 - ADVANCED TAKEOFFS AND LANDINGS

The techniques in this section are usually employed because of operational situations and conditions. A good rule of thumb is to only employ them when necessary.

There will be many occasions where operational considerations, such as high all-up weight, high-density altitude and unfavourable wind conditions or obstacles, dictate the use of advanced techniques. The techniques learned in Exercise 09 and 12 should still continue to be used in normal conditions. When you practise these new skills, it is important to keep a good lookout for obstacles and be sure that the limitations in the Flight Manual are not exceeded.

NO-HOVER TAKEOFF.

The no-hover takeoff can be usefully employed in conditions where snow, dust, ash, sand or debris may cause a hazard if normal techniques are used (Figure 24-1).



Figure 24-1: No-hover takeoff

1. Ensure the RPM is at maximum takeoff setting, and complete pre-takeoff checks;
2. take a careful lookout all around;
3. smoothly apply collective in a single movement to initiate a vertical climb, co-ordinate pedal to keep straight, use cyclic to set the climb attitude as the aircraft passes normal hover height; and
4. when clear of obscuring phenomena adjust controls for normal climb.

As this type of takeoff is not preceded by a hover-check, you have to be sure that the helicopter weight and balance are within limits, and that sufficient power is available for the intended departure.

CUSHION TAKEOFF.

This type of departure is economical in power required, since it involves making maximum use of the ground effect until translational lift is acquired (Figure 24-2). However, a relatively flat area, free of obstacles, is required for this technique. It is useful if the helicopter is heavily loaded and it is not possible to perform an into-wind transition.

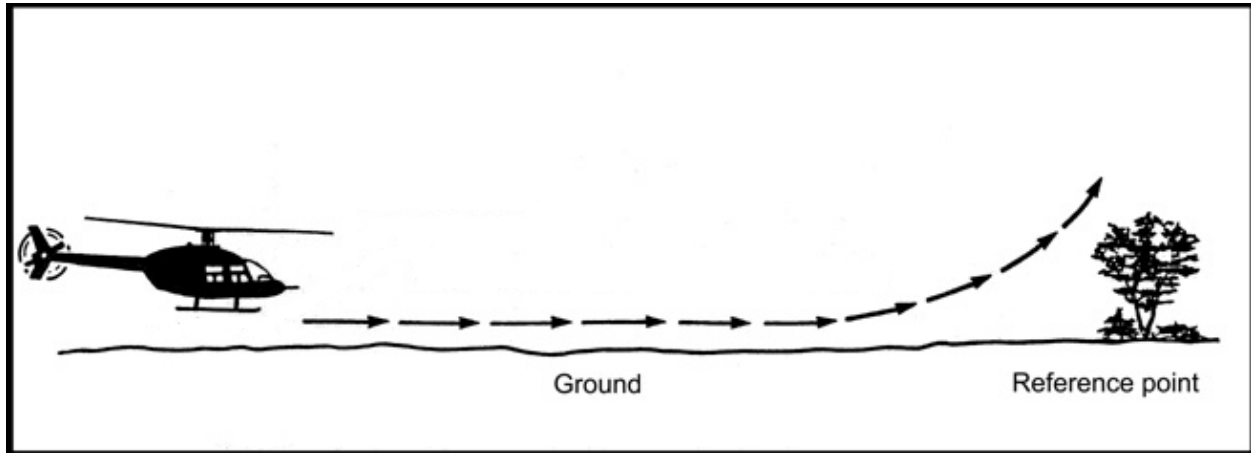

Figure 24-2: Cushion takeoff

1. Perform pre-takeoff checks, and carry out a power check at the low hover;
2. look out;
3. initiate slow forward movement with cyclic and use collective to prevent any tendency to sink;
4. continue a gradual acceleration staying in maximum ground effect; and
5. at approximately 30 - 40 kts, select climb attitude and power.

It is most important to use gentle and smooth control movements to get the maximum benefit from this type of takeoff. The take-off profile is extremely flat initially, so it is essential to look out and keep a close watch on the ground to maintain a safe clearance.

TOWERING TAKEOFF.

This type of takeoff is employed when there are obstacles in the take-off path but the area does not require a vertical ascent. More power will be required but you should use only the amount that is necessary to successfully depart over the obstacle. A good method to ensure obstacle clearance is to maintain the same relative vertical distance between the obstacle and the rotor disc, as viewed from the cockpit.

1. Perform pre-takeoff checks and carry out a power check at the low hover;
2. look out, and select a lateral marker in order to climb vertically initially;
3. from the low hover smoothly apply collective, and climb vertically initially, keep the disc the same vertical distance above the obstacle;
4. when your eyes are level with the top of the obstacle, and still indicating a climb, introduce forward flight; and

5. use power only as required and when clear of the obstacle adjust to normal climb configuration.
6. Using only the power required, as opposed to a vertical departure or “charging” the obstacle, will give you a reserve in the event you have to abort the takeoff. The obstacle can shield the helicopter from the wind, and as you climb you may find you will “pick up” the wind, which will assist the departure. In some wind conditions, you could also encounter turbulence in the lee of the obstacle. This type of takeoff is used for night flying.

VERTICAL TAKEOFF

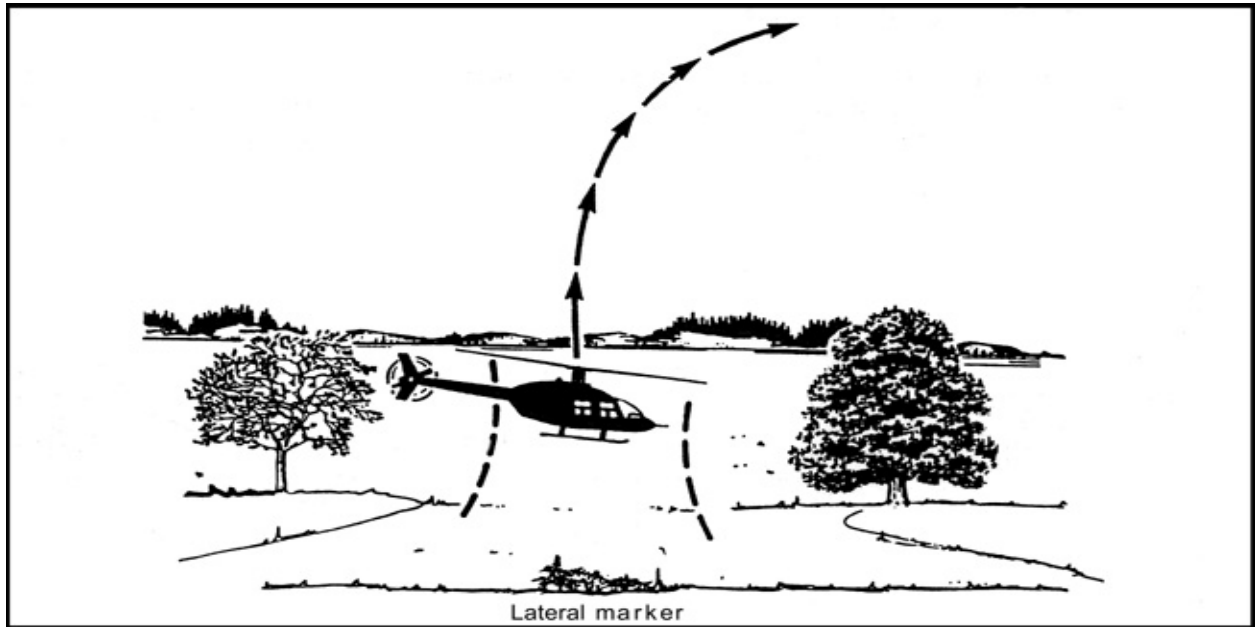

Figure 24-3: Vertical Takeoff

This technique is used when there is insufficient space in the area to perform the methods previously described. The conditions and obstacle height will dictate the power required but much higher power settings are normally the case (Figure 24-3).

1. Perform pre-takeoff checks, and carry out a power check at the low hover;
2. look out, pick references in front and side to ensure a vertical ascent;
3. smoothly apply collective gradually to initiate a gentle vertical climb, adjust cyclic to ensure the climb is vertical by use of references;
4. as the top of the obstacle is reached, ease forward on the cyclic to increase airspeed, make small movements and ensure the aircraft is still climbing before introducing forward flight;
5. when clear of the obstacle, and after attaining translational lift, set normal climb attitude and power; and
6. Make a good lookout all around as you clear the obstacle.

When using this technique, be careful to set a low rate of climb, especially when heavily loaded, because as you lose ground effect you could stop climbing and have to descend. If you use a large amount of collective for a high rate of climb, you need a large amount to stop the helicopter descending and overcome inertia built up on the way down. This could lead to exceed aircraft limitations.

NO-HOVER LANDING

This type of landing is used when it is undesirable to approach to the hover, generally because of snow, dust or ash. It should also be noted that it requires less power than a normal approach and could be utilized in situations where power requirements are high, e.g. heavy loads, hot and high altitude operations:

1. approach the landing area as required; and
2. as the landing spot is achieved at zero groundspeed apply sufficient collective to cushion the landing.

The surface of the selected spot requires a good reconnaissance to confirm its suitability for this type of landing.

RUN-ON LANDING

This type of landing is similar to a No-Hover except it requires less power, but a flat, smooth surface is essential, preferably cleared with a reliable reconnaissance:

1. approach as required;
2. gradually slow the helicopter to a slow walking pace and use sufficient collective to cushion the landing while running on; and
3. after landing, maintain cyclic and collective positions until forward motion stops.

APPROACHES

1. Steep approaches are used when there are obstacles on the approach path or operational conditions require using this technique. Apparent groundspeed will be lower than normal and more power will be required. It is of importance to maintain a low rate of descent on the final stages of the approach to avoid any chance of entering vortex ring state.
2. Shallow approaches use less power than standard or steep, but require an approach path, which is relatively flat and free from obstacles. The technique is used where conditions limit the power available, or where you have maximum power but it is insufficient to use normal procedures. Do not make the approach angle too shallow as this could lead to the use of high power settings, and near the ground, when decelerating the risk of tail rotor strikes.

EXERCISE 25 - CONFINED AREAS

One of the helicopter's most often used capabilities is that of being able to operate in relatively unimproved locations, and to land and take off from confined areas (Figure 25-1) which may be bordered by buildings, high trees or other obstacles. It is essential that the helicopter pilot learn how to operate the helicopter safely in this environment and be able to take full advantage of this unique ability.

You may consider this exercise in seven steps as follows:

1. **High or Initial Reconnaissance.** Your very first step is to positively identify the area in which you wish to land.

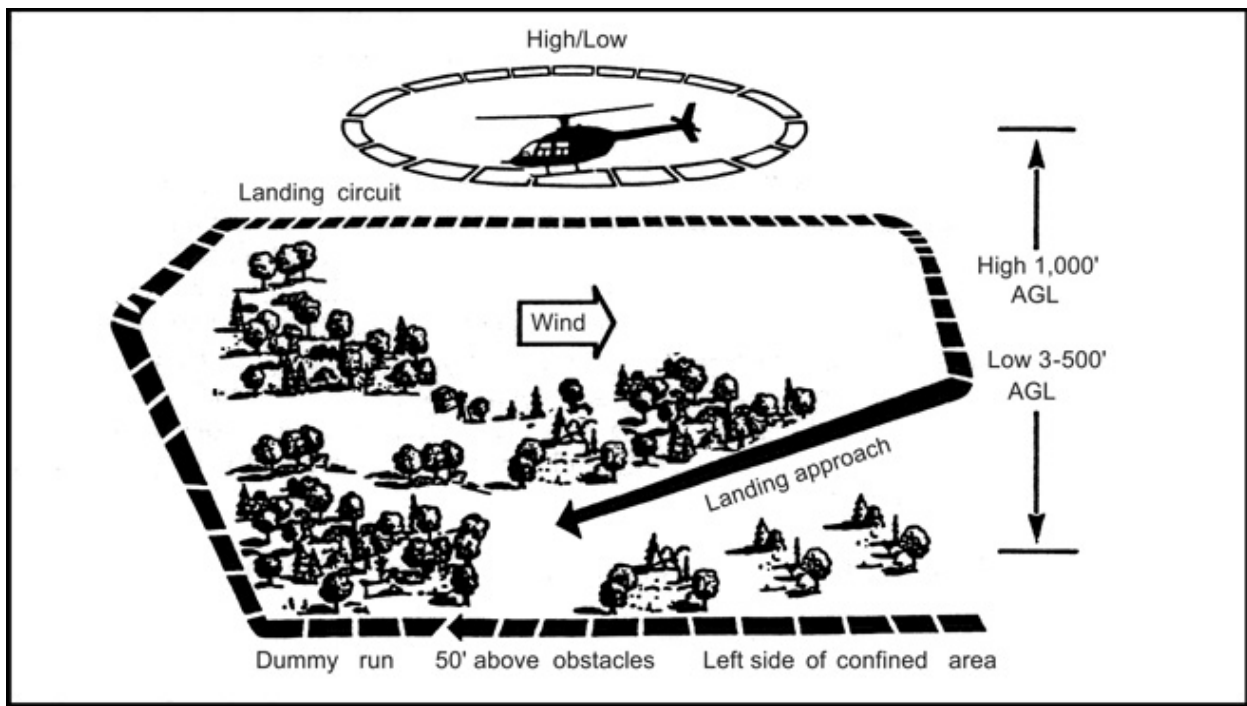

Figure 25-1: Confined area

The initial reconnaissance should generally be flown in a circular pattern to the pilot's side at airspeed of between 50 and 80 mph. In any event the speed should be such to allow a good view of the area throughout the pattern and allow for adequate controllability. The height may be that of arrival at the area but should generally be in the order of 1000 feet AGL. If you are already flying at about 500 feet AGL then you may consider combining the high and low recce into one. Combining the two as you gain more experience will become the normal technique. Variations in the basic confined area technique will be demonstrated as your course progresses.

You should now consider these factors in your high reconnaissance:

- a) **General Suitability.** Establish that the selected area is worth a closer inspection and that no better or more suitable site is in the immediate vicinity.
- b) **Power Available.** The size and “deepness” of the confined area that the helicopter may safely negotiate will vary with the density altitude and its all-up-weight, which in turn determines the power required.
- c) **Wind Velocity.** An initial assessment of the wind should be made; this is to be confirmed during the low reconnaissance.

2. **Low Reconnaissance.** If satisfied with what you have seen during your high reconnaissance, lower the height above ground to proceed to a detailed recon.

Once again the height and airspeed that you fly this reconnaissance will vary according to helicopter type. You must be able to see well enough to make an accurate assessment of the approach track and the landing area. The height will vary between 300 and 500 feet AGL above the nearest obstacles or obstructions. Keep the area on your side of the helicopter during this reconnaissance. After descending from the high reconnaissance check the wind to confirm its direction and strength. Nearby smoke, small ripples on water, long grass, flags or tree leaves are good wind indicators. Quite often in strong winds the approach must be adapted to ensure landing into wind. On other occasions, it may be necessary to accept a crosswind, or in light conditions it may even be able to ignore the wind.

Now check the confined area according to the following:

- a) **Size** – is it big enough?
- b) **Shape** - does the shape favour an approach from any particular direction, bearing in mind the wind speed and direction.
- c) **Slope** - is the ground level enough for a landing?
- d) **Surface** - what is the surface of the area? Are there obstacles that might obstruct a landing such as brush, or might the surface be a hazard such as powder snow or swamp.
- e) **Surrounds** - do the obstacles that encircle the landing area favour an approach (and a departure) from a particular direction. If the trees were shorter on one side, you might wish to consider making your approach from that direction, again the wind can sometimes be the deciding factor in your decision.
- f) **Sun** - is the sun going to restrict the pilot’s visibility during the approach? It is undesirable to make an approach to a confined area landing looking into sun, as it will be extremely difficult to see individual hazards such as “dead head” trees and wires.

To effectively carry out the low reconnaissance, you must be at a height to see well enough to make an accurate evaluation of the approach and departure paths and the landing area. You should select the maximum height that will still allow you to make this judgement. Generally you will find that between 300 and 500 feet above the obstacles will be suitable. Too low and you may lose sight of the landing area; too high and you will be unable to discern details which may determine if the area is suitable.

3. **The Dummy Approach.** During your initial training in confined area procedures and indeed at any time when you feel it might be desirable, you should conduct a dummy approach prior to commencing the actual approach from which you intend to land. The dummy approach is carried out over the same flight path as the intended approach but, rather than a landing, will terminate with an overshoot at the top of the obstacles.

There may be times, when flying the low reconnaissance, when you are unable to see everything that is needed to make a decision as to the suitability of the selected area. In this case you may elect to fly a dummy approach, flying by with the area off to the pilot's side to obtain the best visibility. It may be advisable to perform a power check at this time and to confirm the suitability of the chosen departure path. The need for a power check will be somewhat dependent upon the type of helicopter that you are flying. It is a requirement in a piston-engined helicopter, but may not be meaningful in a turbine-engined helicopter. The best method of determining the power available for your type of helicopter will be demonstrated. The dummy approach also gives an ideal opportunity to check for wires, pick out a lateral marker, landing spot and check for turbulence at treetop level. Look upon this approach as the confirmation of decisions made using the six S's.

4. **The Approach.** Once satisfied with the suitability of the area and having flown the dummy approach to confirm, continue around for the landing approach. The approach angle should not be any steeper than is necessary. If possible, you should be able to see into the confined area, although this is not always practical. There are several types of approaches but only three basic techniques, the single angle, double angle and vertical. The steepness of the approach angle dictates which technique to use, single angle requires the least power for the approach, vertical requires the most. (Figures 25-2, 25-3, 25-4)

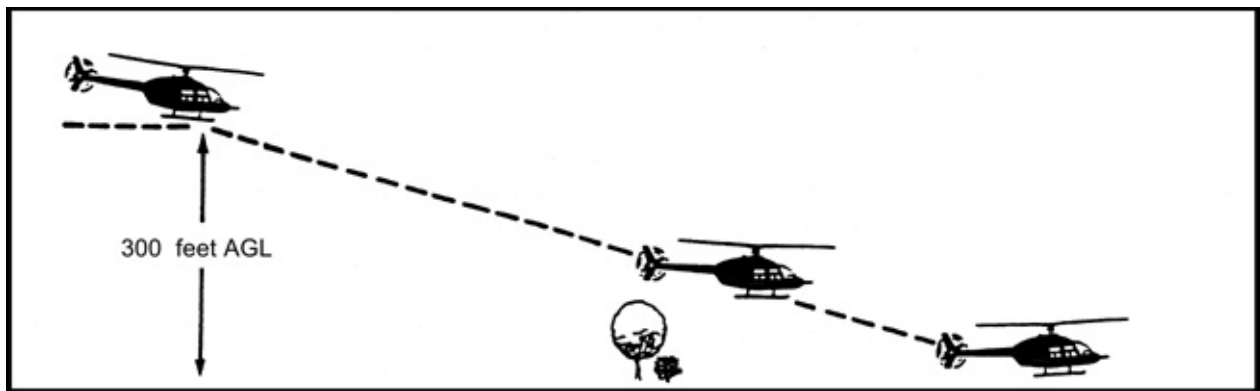

Figure 25-2: Single Angle

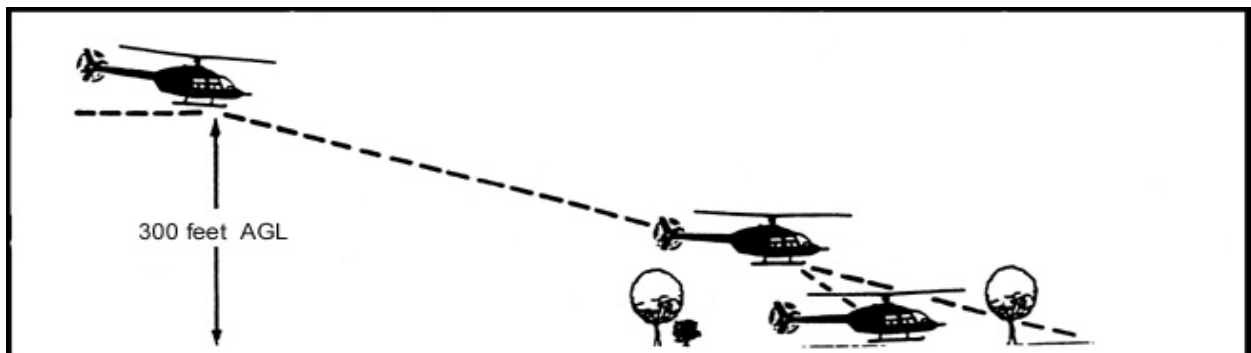

Figure 25-3: Double Angle

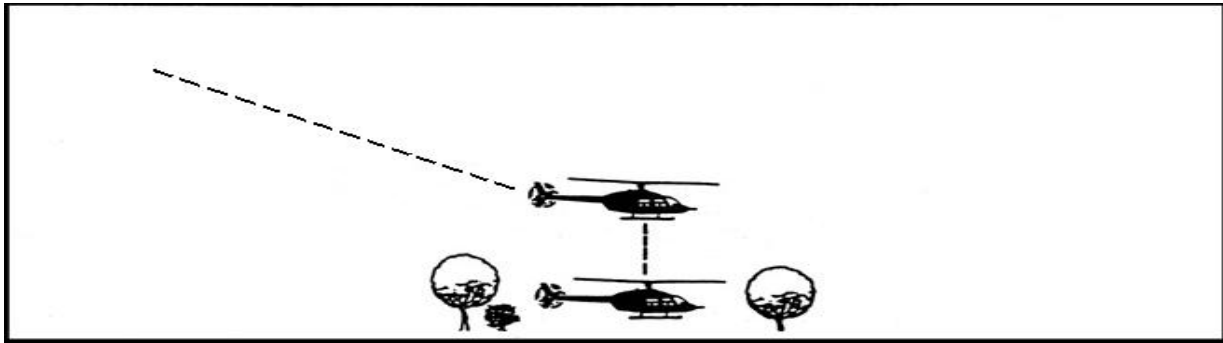

Figure 25-4: Vertical approach

Make your approach to a hover over the ground that you have determined as being suitable for a landing. It would not be prudent to come to a hover over obstacles, or to be in a position where such obstacles might make it hazardous to manoeuvre the helicopter.

5. **Manoeuvring in the zone.** Often you may find that it is necessary to manoeuvre the helicopter inside the confined area, perhaps to move to a more suitable landing spot or to reposition in preparation for departure. Many confined area accidents occur during this manoeuvring and particular attention must be paid to any obstacles that may snag a skid or strike the tail rotor. For this reason, all turns are normally done around the tail, generally to the pilot's side.
6. **The Departure.** In preparation for the departure, manoeuvre the helicopter into a position as far as possible from the obstacles on the take-off path to take advantage of all available space. Look out all around as other aircraft may be in the same area.
7. **The Aborted Departure.** There may be situations where you have to discontinue the take-off and return to a landing within the confined area. This aborted departure is a critical manoeuvre that requires skill and care if it is to be performed safely and effectively.

The earlier in the departure that you make a decision to abort, the easier it will be to recover and return the helicopter to a landing or a hover.

Confined area training begins in relatively large areas that allows for normal approaches and departures, and also allows manoeuvring of the helicopter within the area. Once comfortable in this environment, you will advance to more restricted sites that require steeper approaches, and their size limit your ability to manoeuvre the helicopter. Out of wind approaches are practised, as the shape of the area or the surrounding obstacles often demands them.

NOTE: *There is a great need to exercise your common sense in this exercise. The easiest way is normally the best way generally holds true for confined area work.*

EXERCISE 26 - VORTEX RING

If the helicopter pilot chooses a flight path, airspeed and a rate of descent that coincides with the aircraft's downwash, the helicopter could enter a condition known as the Vortex Ring state. The stall condition formed by the rate of descent flow in opposition to the induced flow, combines with the tip vortices present in all regimes of flight to produce a turbulent rotational flow on the blades and an unsteady spanwise shifting of that flow. This condition induces a very rapid rate of descent, vibrations, excessive flapping and a reduction in cyclic authority that could result in an accident. Obviously, this condition is to be avoided and the helicopter pilot should be able to recognize the incipient stage and be able to affect a safe recovery.

Your instructor will review the causes, conditions and symptoms of vortex ring. During a steep approach, at a high gross weight, high-density altitude and in a downwind or light wind condition; the helicopter may enter its own downwash and the development of vortex ring state. This situation would certainly contribute to the onset of vortex ring, but not necessarily cause it. The phenomenon is most likely to occur when all the conditions listed below are present:

1. in powered flight;
2. high rate of descent, in excess of 500 feet per minute; and
3. low airspeed, less than 20 MPH indicated.

Almost every transition from forward flight to a hover utilizes a powered approach, a rate of descent and a reduced airspeed. To prevent the occurrence of vortex ring, control your rate of descent less than 300 feet per minute.

Recovery Techniques. There are two methods of effective recovery from the vortex ring state. Both change the airflow conditions causing it and both involve a loss of height:

1. Dive out. Normally this technique will result in less altitude loss than with the autorotational recovery. The pilot should apply forward cyclic while reducing the collective; the vortices will leave the disc as the airspeed increases and the helicopter will move forward of its downwash. Normal flight may then be resumed.
2. Enter autorotation. By this method, the airflow through the rotor changes from the disturbed flow of the vortex ring to the upward autorotational flow. Once autorotational descent has commenced then the pilot may ease the cyclic forward to gain airspeed while power is increased and normal flight resumed.

You should note that an increase in collective alone may not result in a recovery and indeed may only serve to increase the rate of descent. This increase in blade pitch will cause the vortices to intensify in strength and will result in a more rapid descent.

There are some uninformed pilots who use "settling with power" to describe vortex ring, in fact some publications use the terms interchangeably. Confusion results when symptoms are related that do not describe true vortex ring but rather describe "settling with insufficient power". This may occur when a pilot attempts to arrest a rapid, low power descent only to find that he has insufficient power available to bring the helicopter to either a hover or a no-hover landing without exceeding the engine limits. However, this is not a vortex ring situation.

Another situation, 'over-pitching' is often misinterpreted as vortex ring. This is where the pilot rapidly increases collective considerably and the engine cannot produce enough power to overcome the large, swift increase in drag on the rotor system. The result is that the rotor system quickly slows down and loses efficiency causing the helicopter instantly to sink. Again, this is not vortex ring.

The most common situations, where you would be most likely to encounter vortex ring, are usually when you misjudge the wind with a heavy load on a hot day. Downwind approaches to a confined area, or a mountain pad, are two good examples. Always control your rate of descent carefully on these occasions, and make sure an escape route is available. Your instructor will discuss the symptoms and recovery techniques more fully. Demonstration of this exercise is not generally performed, as the stresses on the airframe and rotor system are unknown.

PREVENTION IS BETTER THAN CURE!!!

EXERCISE 27 - PRACTICAL LOADING AND MAXIMUM WEIGHT OPERATIONS

Loading and maximum weight operations are shown here to be one particular exercise. Realistically, you will be gaining experience in this exercise almost from the day you start your course. To operate a helicopter to its full capabilities, a thorough understanding of its limitations is required. All helicopters have definite limitations with regard to both weight and balance.

It is the responsibility of the pilot-in-command to load the helicopter within the limitations set out in the authorized weight and balance section of the flight manual. To simplify loading problems, manufacturers supply pre-calculated graphs, charts and loading examples. You will be shown how to calculate the weight and balance for your type of helicopter.

In normal working conditions, because your loads are frequently varied, you should be familiar with the effects of these variations. A check of weight and balance should be included among the factors considered by the pilot in his pre-takeoff checks. If in any doubt, always calculate with either the charts, or reports, before attempting the load. Always perform a hover-check; this will give you an accurate check of the power being used, and therefore what is still available to you, and how the load is affecting your centre of gravity.

POWER REQUIREMENTS

You will be shown how to estimate the power required for different situations. The hover-check is really the accurate way to practically find the power required and permit you to evaluate the power available on that particular flight. Remember that a few degrees in temperature and/or a change in altitude can make noticeable changes in the performance of your helicopter.

LOADING AND UNLOADING CARGO

You will be shown how to maximize the space available with varied loads on the particular type you are flying. This will include all baggage compartments and litters in addition to the cabin. You must secure all loads utilising straps, nets, or any restraining device available. As some loads may be classed as dangerous goods, check in the company operations manual to determine how to handle them before you commit to loading them in the aircraft. Unloading is as important as loading. If you are carrying loads to several destinations, arrange them for ease of delivery, but be sure to arrange them so as to have as little effect on weight and balance as possible. Always perform your hover-check after each stop. Sling loads are dealt with in Exercise 28.

PASSENGERS

The pilot-in-command is responsible for briefing any passengers carried on board the aircraft. Passengers have to be shown how to embark and disembark safely, the use of seat belts, procedures to be used in the event of emergency, including exits, and policy on smoking whilst in the helicopter. Most helicopter company operations manuals have a safety-briefing checklist included in them to ensure nothing is forgotten. Always use it if available.

In conclusion, use your common sense when you are working. Remember that increasing your weight, altitude or both, affects performance not only in powered flight but also in autorotation.

EXERCISE 28 - SLING LOAD OPERATIONS

One of the features of the helicopter, which sets it aside from other aircraft, is the ability to transport many different types of loads suspended from a cargo hook. This unique transportation method allows the helicopter to deliver cargo where even it cannot land, and to perform highly specialized tasks such as water bucketing, logging, and aerial construction. It is essential that to carry out safe slinging operations, the pilot and ground personnel involved be thoroughly conversant with the techniques required.

For the purpose of this exercise and indeed, for any slinging that you do operationally, carefully select the routes that you will fly to ensure that you do not overfly built-up areas to minimize the danger to persons or property. Your instructor will review with you Sections 602.16 and 602.23 of the Canadian Aviation Regulations prior to the conduct of this exercise.

PRE-FLIGHT CHECKS

Prior to conducting any slinging operations you should carry out the following checks in addition to your normal pre-flight inspection:

1. check the cargo hook is correctly fitted and undamaged, and that all suspension, electrical and mechanical cables are secure and there is no evidence of fraying or chafing;
2. check that the normal release mechanism is fully functional by physically checking that the hook opens when the release is activated;
3. check that the emergency release system is functional by physically checking that the hook operates when the emergency release is activated;
4. inspect all slings, straps, and nets for general condition. Frayed and worn equipment could present a hazard in flight. Ensure that the available equipment is capable of safely carrying the weight of the planned load; and
5. inspect your mirror and position it so that you can see comfortably from your seat.

Having satisfied yourself that all helicopter and sling equipment is serviceable, you may brief any ground personnel that you may have assisting you. This type of operation requires a qualified ground crew, appropriated equipment and a good coordination of the team. It is important that you clearly establish what signals you will use during the operation, including the actions of both the ground crew and you, should an emergency occur during the hook-up or load release phases. Standard hand signals to be used during slinging are shown in the following diagram.

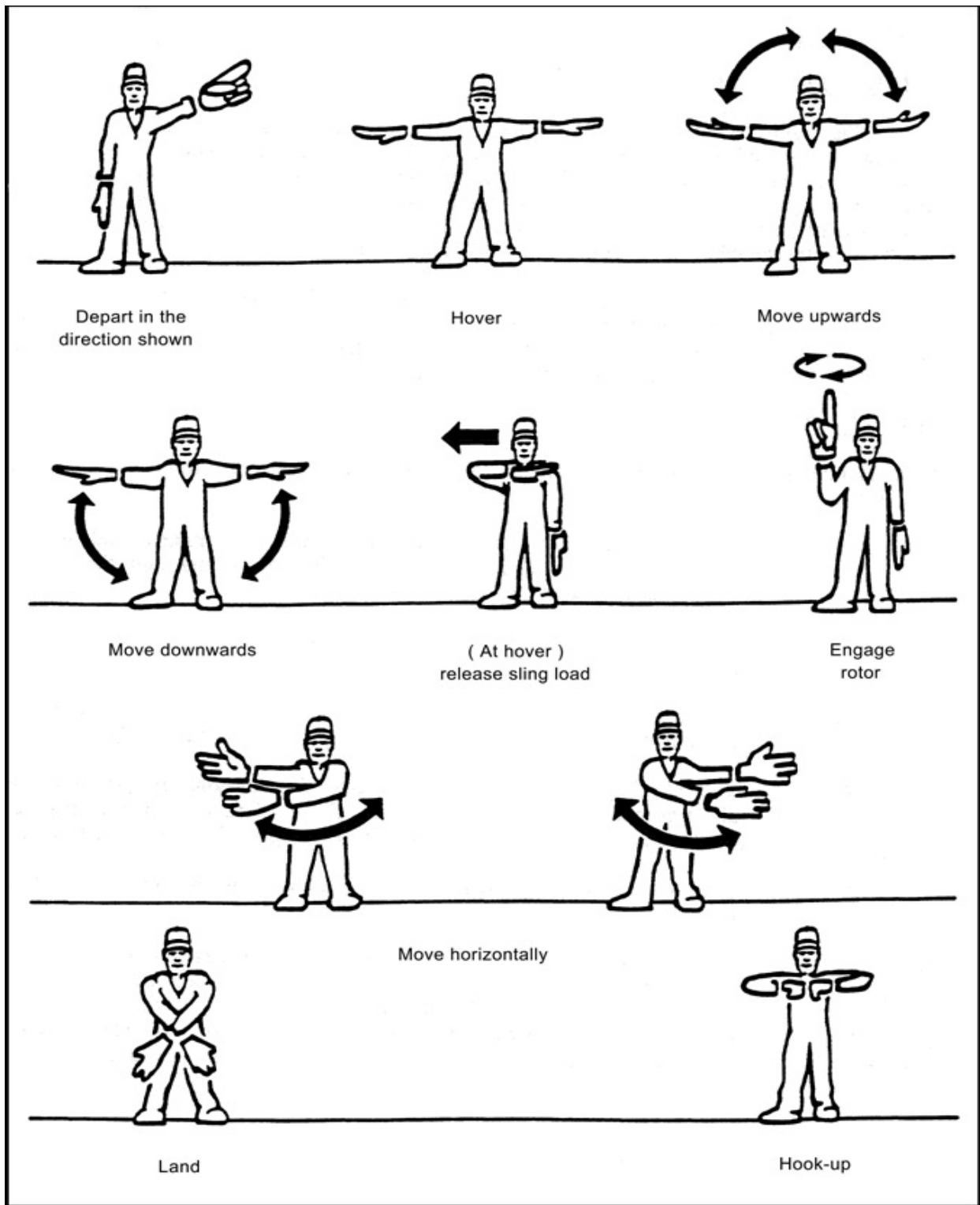

Figure 28-1: Marshalling Signals for Helicopters

All external loads may be categorized as one of: high density, low density or aerodynamic. The high-density load will be stable while the low density will be decidedly unstable; the aerodynamic load may exhibit both characteristics. You should study the load to determine which description best suits it, and then estimate how it will likely fly.

PICKING UP THE LOAD

Whenever possible, position the load so that you can hover the helicopter into wind during the pick-up procedure. This will provide for the most stable hover. If assisted, the marshaller should be positioned in plain view, back to the wind. Usually this will be slightly right of directly in front of the cockpit, about 50 feet away from the helicopter. This position will allow the marshaller to monitor the load as it is lifted off the ground, and to observe a wide area around the helicopter in the interest of safety. It will also make sure that the pilot can see the marshaller. Once in the hover over the load, at the appropriate height, select some easily visible references. Keep these in view as you increase the hover height after hook-up to maintain as vertical a liftoff as possible.

During the hook-up, ground personnel should not position themselves between the load and the helicopter; include this point in your pre-flight briefing. Once the load is attached to the hook, you may commence a slow vertical ascent until the sling becomes taut and the helicopter is centred over the load. Brief the marshaller to position the helicopter directly over the load once you have lifted into the hover. Continue increasing collective while crosschecking the manifold pressure gauge (or torquemeter on turbine engined helicopters) to determine whether sufficient power is available for the transition to forward flight. This portion of the takeoff should be made smoothly to ensure that the load is secure and properly rigged prior to the transition.

THE TAKEOFF

Once you are satisfied that all criteria have been met for flight, initiate an altitude over airspeed transition to forward flight. This type of takeoff will ensure that obstacle clearance is achieved rapidly. When at a safe height, allow the airspeed to increase slowly to a speed that will allow the most control over the load. Check for limitations in the flight manual, in any event it is of little advantage to fly faster than 90 mph with any sling load. As the speed increases, pay attention to the flying characteristics of the load and, should oscillations begin, smoothly reduce the airspeed. In this way, you will establish the maximum safe flying speed for your load. Once safely into forward flight, select the cargo hook master switch to "off" (if your helicopter is so equipped).

It is important to reduce the airspeed at the first sign of an oscillation, but do not lower the collective rapidly. All control inputs should be gentle and smooth. Reducing collective (and thereby airspeed) and entering a shallow bank has often proven effective in reducing load oscillations.

APPROACH TO RELEASE POINT

If at all possible, plan your approach into wind to preclude the possibility of entering a situation where there is insufficient power available to arrest the descent. An approach angle slightly steeper than normal will ensure that obstacle clearance is provided until the helicopter is over the load release point. Attempt to "fly the load", observing its speed over the ground, to avoid overshooting the release point. Perform a pre-landing check and set the cargo hook master switch to "on". Control your rate of descent.

RELEASING THE LOAD

When the helicopter has stabilized over the load, smoothly lower the collective to begin a controlled rate of descent, until the load is gently placed on the ground. Further lower the collective to create slack in the sling. Depending on the weight of the load, there may be a considerable reduction in collective at this point. Once the sling is slack, release the hook. Before clearing the area, verify that the load has in fact released, and the sling has not hung up, by checking in your mirror or moving a little to one side.

SAFETY PRECAUTIONS

A study of helicopter accidents in Canada will reveal that many are associated with slinging operations. Most are preventable. Plan the slinging you undertake, estimate the flying characteristics of the load, and fly with accuracy and precision. Never let the oscillations of the load reach a magnitude that endangers you and the helicopter; far better to jettison the load than to lose the helicopter. In the event of any emergency in flight jettison the load.

UNUSUAL LOADS

Over the years, you will be asked to sling different loads. In the diagrams below are several ideas, which have worked over the years. Most loads should be comparable to one of the following:

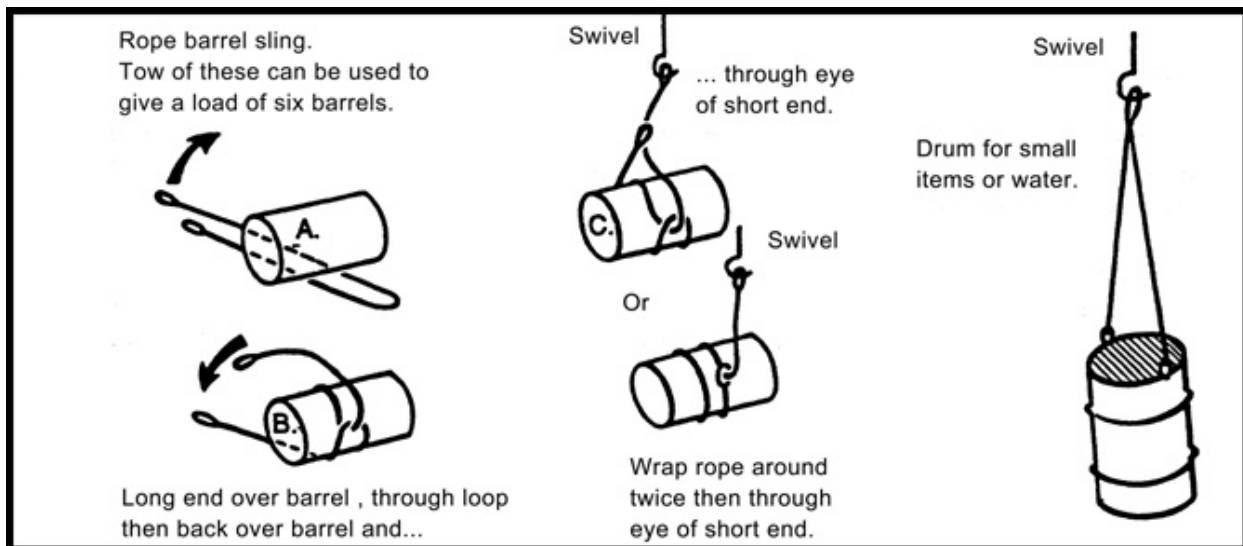

Figure 28-2: Barrel Lifts

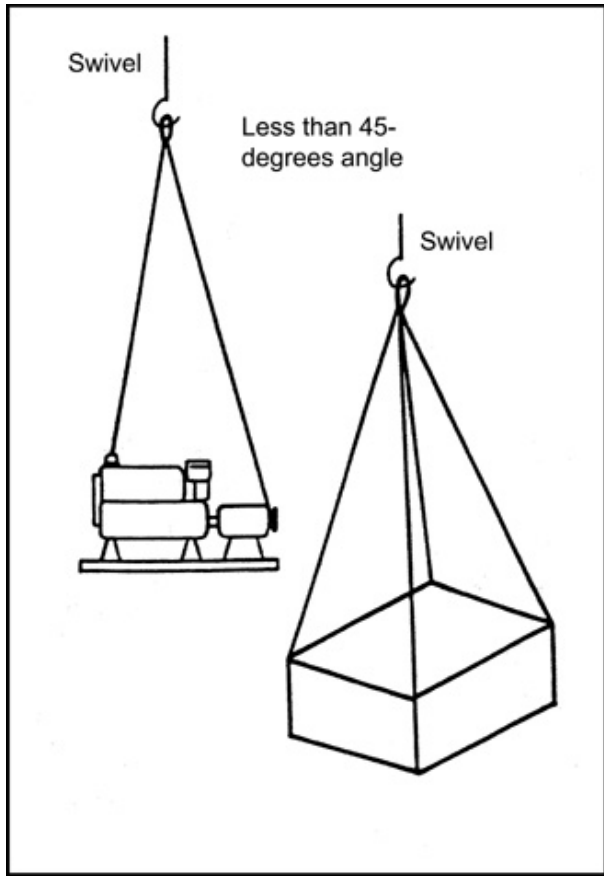

Figure 28-3: Sling Lifts

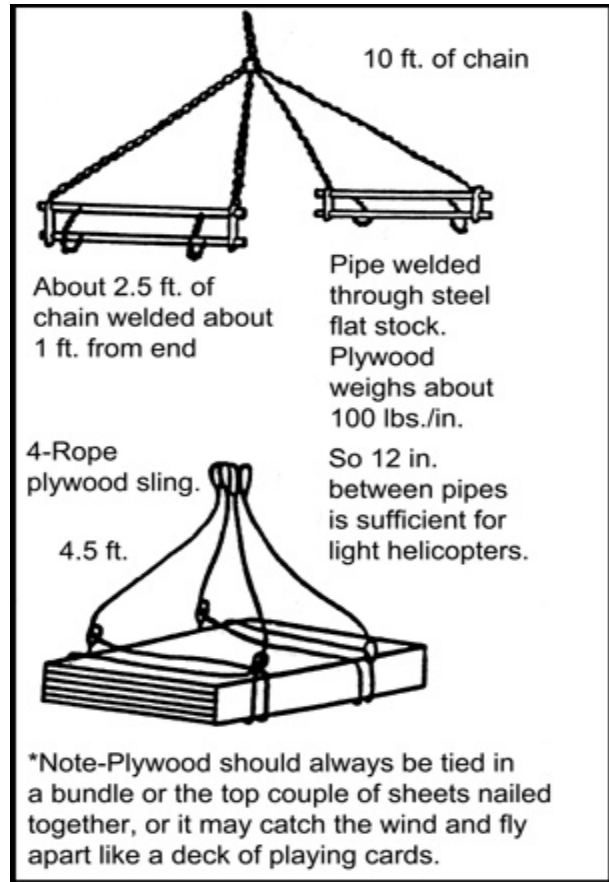

Figure 28-4: Sling Lifts

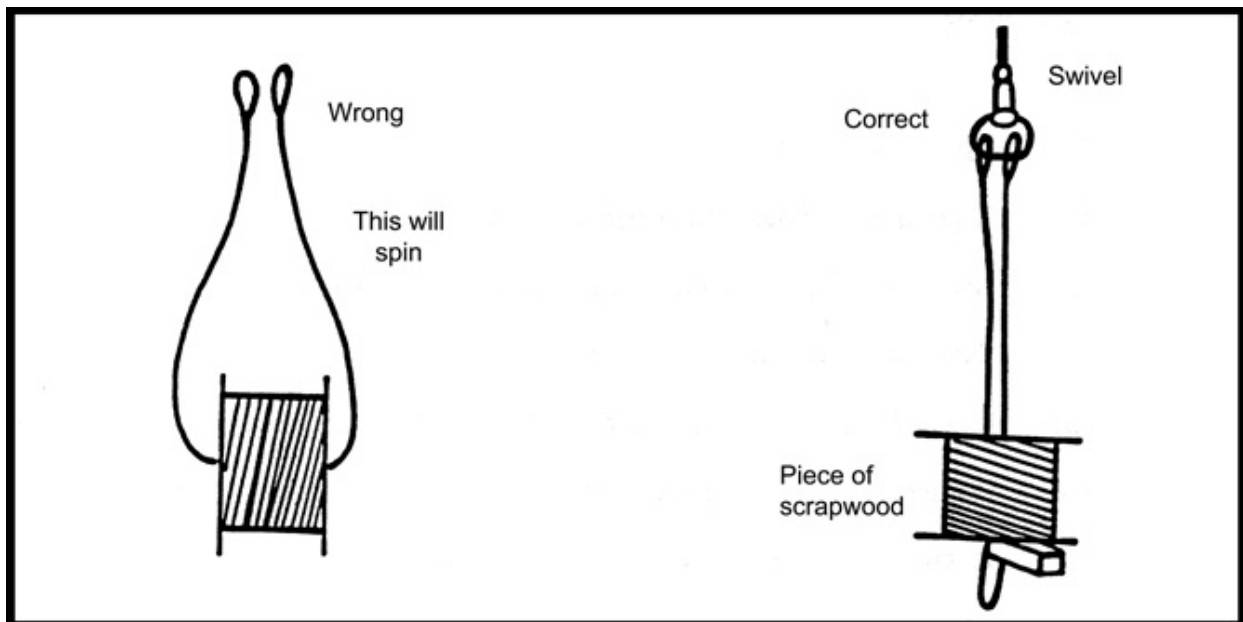

Figure 28-5: Swivel

OPERATIONAL TIPS

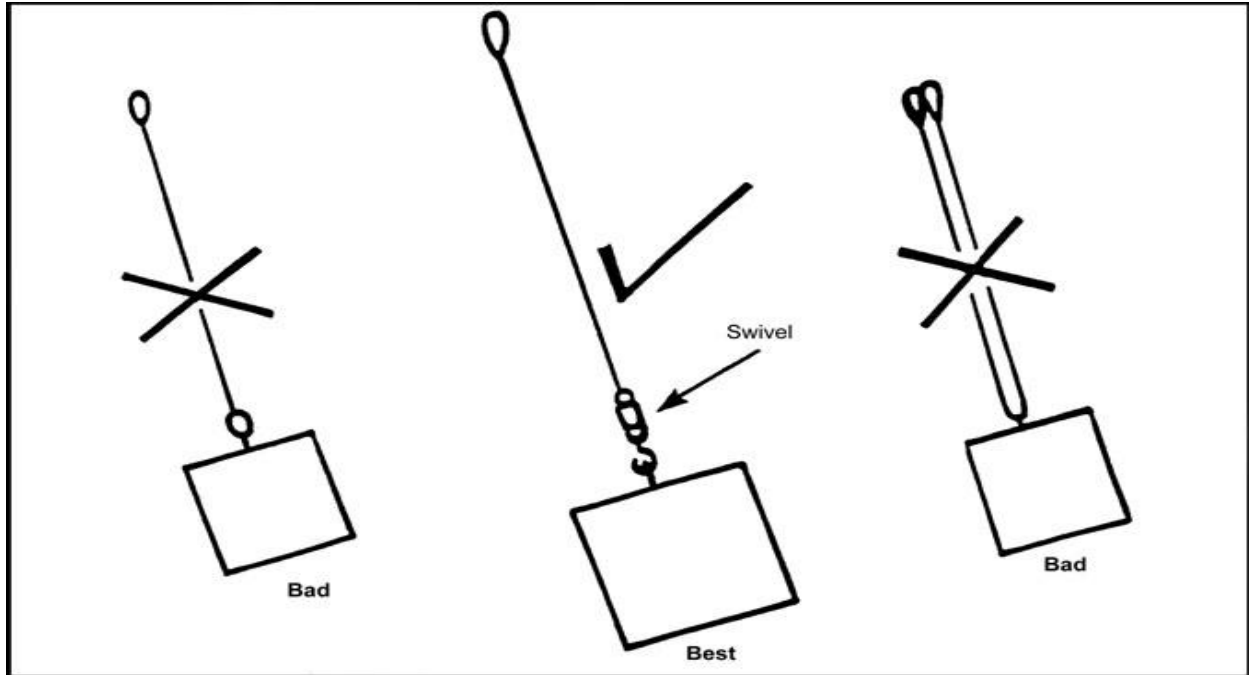

Figure 28-6: Swivel

1. Always use a swivel.
2. If possible operate from level, large areas.
3. Keep area clear of debris; hats, scarves, tarps, boards, etc.
4. Resist the urge for more speed.
5. Empty barrels are a poor load, FULL barrels are good one.
6. On aerodynamic loads spoil the lift with a tree or barrel.
7. In #6, the heavier the load the better it flies.
8. Always keep RPM on high side.
9. Beware of static electricity.
10. On approach, control the rate of descent carefully.
11. Plan the best fuel load according to the sling operation.
12. Clear area after delivery of load as quickly as possible; remember the crew on the ground have no protection from the downwash.

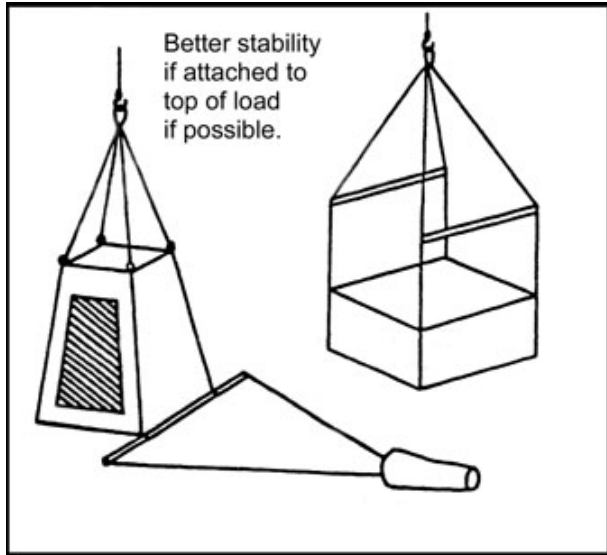

Figure 28-7: Wind Vane on Load

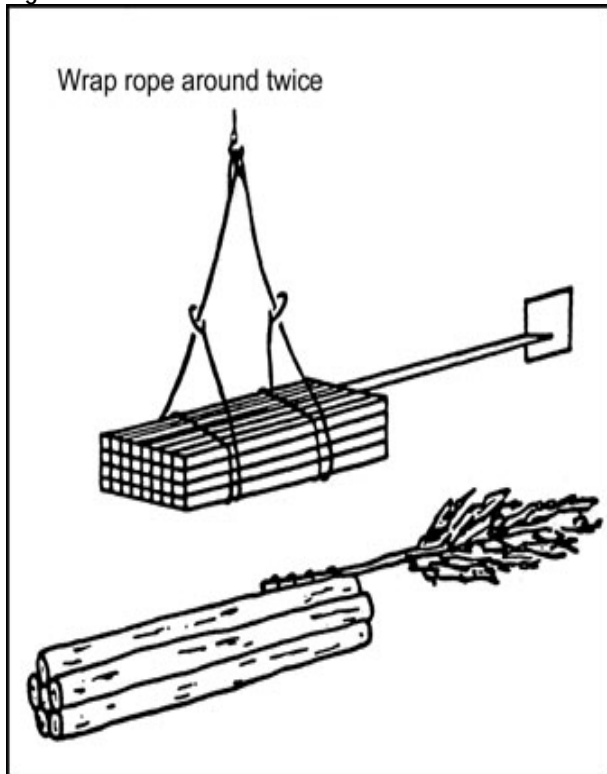

Figure 28-8: Wind Vane on Load

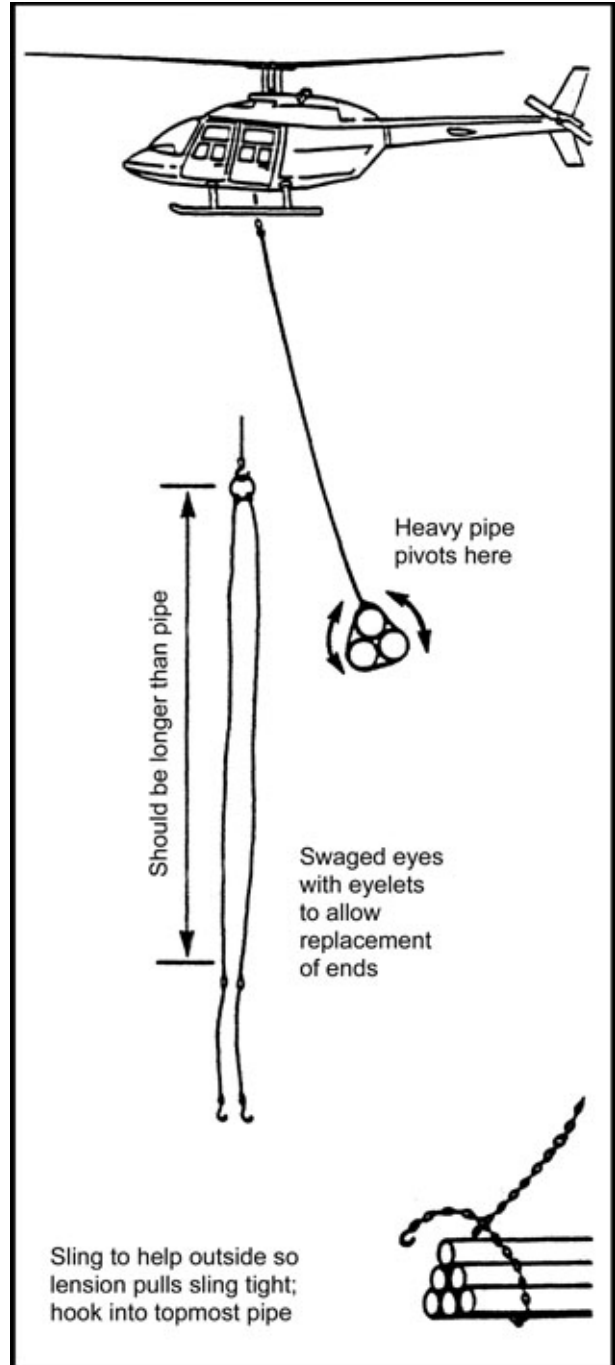

Figure 28-9: Lifting Pipe

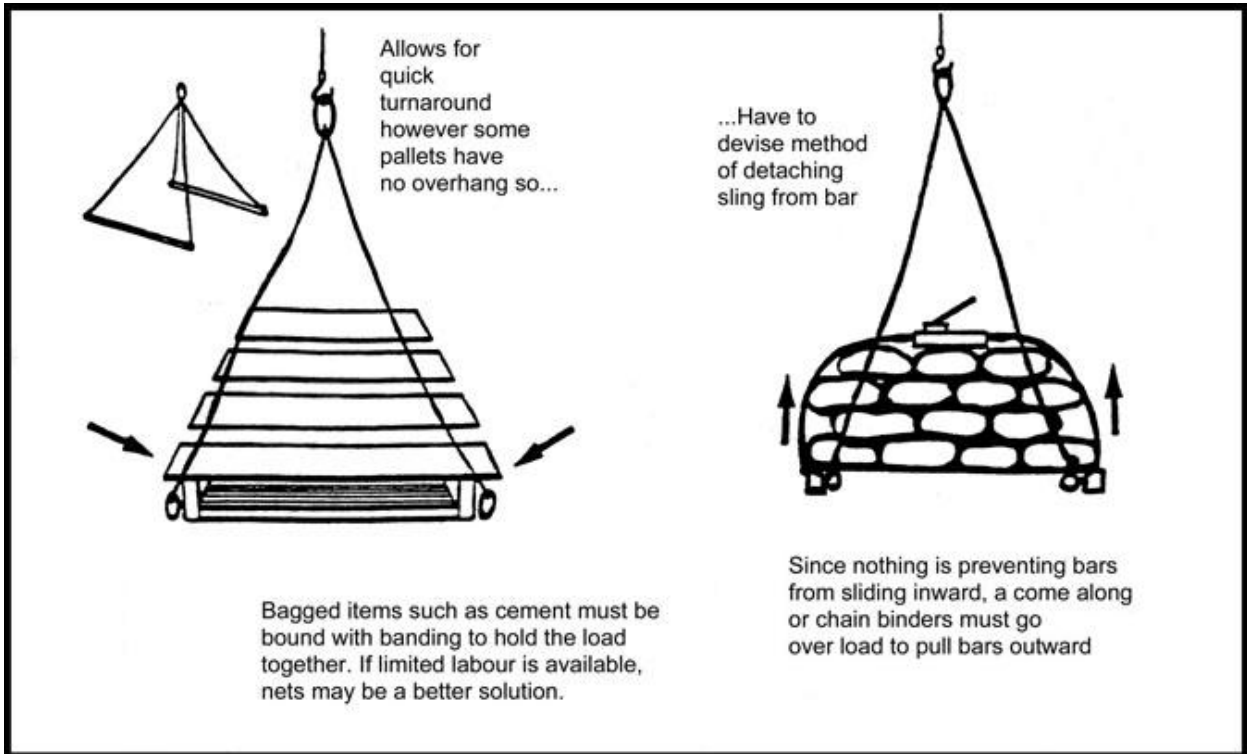

Figure 28-10: Lifting Pallets

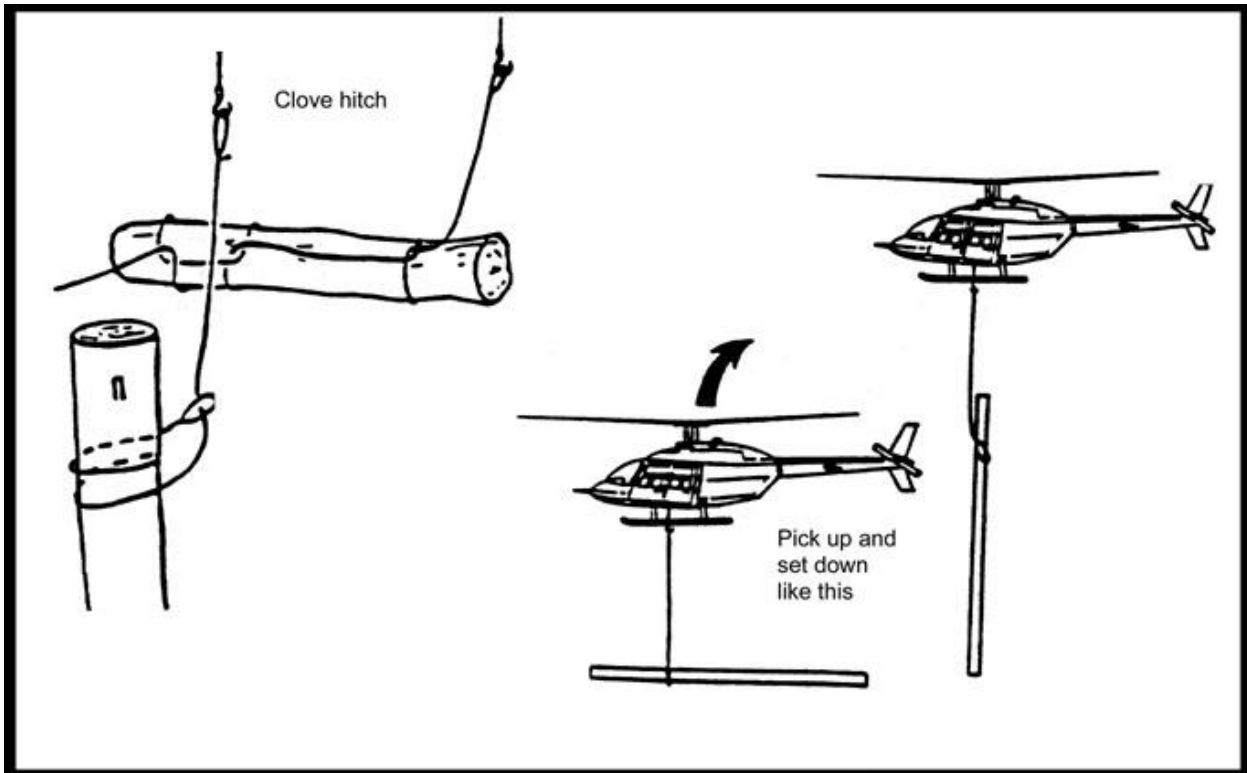

Figure 28-11: Lifting Poles

EXERCISE 29 - TYPE CONVERSION

The reasoning behind the type conversion exercise is that there are many types of helicopters; each has different power plants, rotors, flight controls, hydraulic and electrical systems. As a result, the handling characteristics, capabilities and limitations are different for each type.

Helicopter pilots in Canada are required to have their licences endorsed for each type of helicopter they intend to fly. As a helicopter pilot, you may be required to fly several types of helicopter. In this exercise your instructor will teach you the necessary knowledge and in-flight experience to convert you safely and effectively from one type to another.

A thorough conversion is essential to flight safety, particularly when converting from a piston to a turbine-powered helicopter or vice versa.

KNOWLEDGE

The majority of the information taught is contained in the flight manual. This is often supplemented by additional training publications. It is essential you have a thorough working knowledge of the different systems and procedures contained in all these publications.

SYSTEMS AND PROCEDURES

1. Normal procedures for daily inspections, start-up and shutdown.
2. Normal in-flight procedures
3. Emergencies.
4. Capacities and fuel consumption.
5. Systems appropriate to type, e.g. hydraulics, transmission, electrical, fuel and oil.

PERFORMANCE

Particular attention should be paid to the **limitations** section including:

1. airspeeds;
2. all-up weight and centre of gravity; and
3. rotor and engine limits.

EXPERIENCE

The knowledge acquired will now be applied practically as your instructor commences the flight training necessary for the conversion. The following points will be emphasized:

1. control response differences. The type of rotor system will affect the control response particularly between high and low inertia rotor systems. There will also be quite noticeable changes in the response and feel between rigid, semi-rigid and articulated rotors; and obvious differences to clockwise and anti-clockwise turning rotor blades;
2. visual cues and instrument readings. Instrument presentations and panel layouts vary, as does seating for the pilot-in-command, sometimes right, sometimes left, depending on type;
3. idiosyncrasies. Each helicopter has its particularities, for example, vibration at certain airspeeds or flight conditions;
4. ancillary controls. These vary from type to type, examples are pitot heat, blower defogging and heater controls.

The time required for a conversion will vary with your experience, skill and helicopter type. Regardless, a successful conversion is dependent on a sound knowledge of the aircraft, and the skill to perform all normal and emergency procedures safely and accurately.

EXERCISE 30 - INSTRUMENT FLYING

Any situation likely to place a VFR pilot in instrument meteorological conditions (IMC) should be avoided, nevertheless, every year there are instances of pilots accidentally flying into cloud or whiteout conditions. The instrument instruction taught on the private and commercial pilot course does not qualify any pilot to fly IFR. It is designed to assist the pilot who is not IFR qualified, flying a helicopter not suitably equipped, to transition back to visual meteorological conditions (VMC) from inadvertent IMC.

By far the safest and most expedient procedure for a VFR pilot is the time honoured 180 degree turn back to VMC. This procedure is the most appropriate for VFR flights at VFR altitudes, night flights that encounter IMC, or where IMC is a local phenomena, e.g. fog, blowing snow or ice crystals. To achieve the 180 degree turn the pilot must:

1. control the helicopter and revert to instrument flight, noting altitude, airspeed and heading;
2. maintain or climb to an altitude to safely clear the surrounding terrain;
3. execute a rate one turn to the reciprocal heading; and
4. maintain instrument flight until VMC is regained, then another decision will be required, to either proceed, turn back, or to land.

Attitude instrument flying is essentially visual flying with the flight instruments substituted for the natural horizon and various reference points around the helicopter. In flight, the instruments provide information concerning:

1. helicopter attitude;
2. power required; and
3. whether the combination of attitude and power is providing the desired performance.

This exercise description is general in nature as the instrument portion of the course is taught using different methods at different schools. Students should not be overawed by the prospect of instrument flying, as much of it is linked to basic manoeuvres already mastered early in the course, and the majority of the theory is in review of subjects already understood.

AIRCRAFT CONTROL

1. Control inputs that produce movements are the same as those used in visual flight.
2. Control pressures should be smooth, make small corrections and wait for the results.
3. Students must anticipate the need to change power and attitude to arrive at desired airspeeds and altitudes when accelerating, decelerating, climbing, descending, and levelling off.
4. Refer to control instruments to establish attitude and power, refer to performance instruments to verify airspeed, vertical speed, or other desired performance.

ATTITUDE CONTROL

The attitude of the helicopter is controlled by movement around its pitch (lateral), roll (longitudinal), and yaw (vertical) axes. The three helicopter flight controls are:

1. Cyclic (attitude control)
 - a) Pitch Attitude Control. The movement of the helicopter about the lateral axis (nose up/down), involves changing the longitudinal tilt of the main rotor (cyclically).
 - b) Bank Attitude Control. The movement of the helicopter about the longitudinal axis (roll), involves controlling the angle made by the lateral tilt of the rotor disc and the natural horizon.
2. Collective (power/thrust control)

Adjusting collective pitch results in a collective angle of attack change of the same amount on each rotor blade.
3. Pedals (yaw control for co-ordinated flight and trim)

Pedal co-ordination to compensate for all power changes.

POWER CONTROL

1. On a helicopter, both lift and thrust originate from a single source, the main rotor. Therefore, to properly change, or maintain, any desired altitude/airspeed a student should know the appropriate power settings required for the training helicopter. For example a Robinson R22 requires approximately 20 inches of Manifold Pressure (MP) in cruise at 80 knots. To climb or descend at 500 feet per minute, at 80 knots, will take approximately 2 inches MP adjustment to the cruise power setting.
2. Power settings are controlled exactly the same as for visual flight via the collective, and displayed by the torquemeter or manifold pressure gauge. The effects of moving the collective are also identical to visual flight, i.e. when power is added, the nose will pitch up and yaw right in North American rotation. The reverse is true when the collective is lowered.
3. At a given airspeed, specific power settings will determine if the helicopter is climbing, descending, or in level flight. Increasing the power while maintaining a constant airspeed results in a climb, while decreasing the power has the opposite effect.
4. At a constant altitude, the power setting will determine the airspeed. When the power is increased, the nose will have to be eased down to maintain altitude, then the airspeed increases. The reverse applies when power is decreased.
5. Constant altitude and airspeed in level flight are reliant on co-ordination of attitude and power.

When power is adjusted for airspeed or altitude, the helicopter attitude will be affected, the amount and direction depends on the change made or required. Attitude and bank must be adjusted and yaw eliminated to maintain co-ordinated flight.

CONTROL AND PERFORMANCE INSTRUMENTS

The control and performance instruments are grouped as follows:

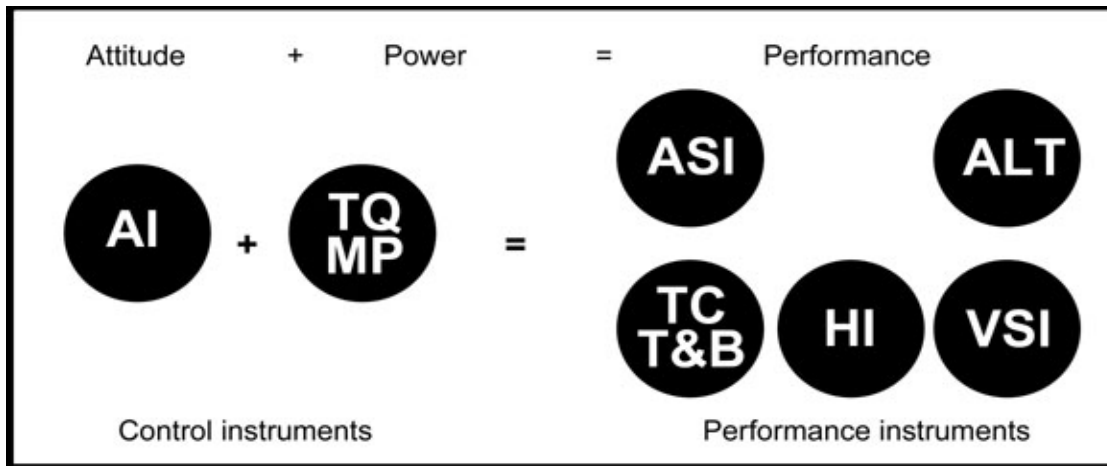

Figure 30-1:

1. Control instrument interpretations are made by reference to:
 - a) attitude indicator; and
 - b) torquemeter or manifold pressure gauge.
2. Performance instruments display the effects of the control instrument changes on the helicopter flight path by the following instruments:
 - a) airspeed indicator (ASI);
 - b) altimeter;
 - c) vertical speed indicator (VSI);
 - d) heading indicator or compass, and
 - e) turn and bank indicator or turn coordinator.
3. Corrections made with reference to the control instruments are made on the basis of information received from the performance instruments.
4. Employments of the control and performance theory apply for all instrument manoeuvres; cyclic (attitude) controls airspeed and collective (power) controls altitude or rate of altitude change. Variation of the attitude in flight has an immediate effect on airspeed and, as a by-product, a change in altitude. A change in power will have an immediate effect on altitude and a lesser effect on airspeed.
5. The interpretation of the attitude indicator in helicopter flying must also be discussed. The attitude indicator in a helicopter displays fuselage attitude not disc attitude. A helicopter can climb or descend with a nose up, down, or level attitude. The attitude indicator is the only instrument that provides a direct indication of attitude. However, it does not always represent disc attitude and therefore does not accurately display what the helicopter is doing. For example, the attitude indicator may show a nose up attitude, while in reality the helicopter is descending at 90 knots. The attitude indicator must always be crosschecked with the performance instruments to ensure valid interpretation of the presented information.

6. At a constant airspeed, the power setting determines whether the helicopter is climbing, descending, or in level flight. Conversely, if the altitude is held constant, the power and attitude settings will determine whether airspeed is increasing, decreasing, or constant.
7. The relationship between varying power and attitude is so similar that the true reason for a deviation in airspeed, altitude, or heading is not always apparent. The heading or altitude can change without a corresponding change in attitude. Correct interpretation of information provided by the attitude indicator alone is often a difficult process. This demands correct interpretation of all control and performance instruments for stable co-ordinated flight.

PITCH ATTITUDE CONTROL

The performance instruments for pitch attitude control reference are:

1. Attitude Indicator (control)

The easiest method of visualizing the helicopter attitude, when using the attitude indicator, is to imagine the wings of the miniature aircraft as the rotor disc. The attitude indicator provides general pitch information and is used in conjunction with the other pitch instruments. In cruise flight, the rotor disc should be superimposed on the horizon bar. If the rotor disc rises above the horizon, the VSI and altimeter should confirm a climb, and the airspeed should decay. Small gains or losses of altitude, not exceeding 1.5 bar widths, are made by easing the nose up or down with cyclic. The performance should then be crosschecked against the other pitch instruments. If larger changes are required, power will likely have to be adjusted.

2. Altimeter

The altimeter provides indirect pitch information in cruise flight. Since the helicopter can ascend or descend in the cruise attitude, without an attitude change, the altimeter must be used in conjunction with the other pitch instruments. The altimeter is not a rate instrument and is of limited value if used in this capacity. Fixating on this instrument can lead to “chasing” and overcontrolling if it is used as the sole reference for pitch information.

3. Vertical Speed Indicator (VSI)

The VSI is essentially a trend instrument and should always be used in conjunction with the other pitch attitude instruments. In cruise, the needle indicates zero. Use the VSI together with the altimeter to correct deviations from level flight. Since there is a time lag associated with the VSI, fixating on this instrument can lead to “chasing” the indications, leading to a porpoising effect. Overcorrection leads to overcontrolling. To eliminate overcontrolling, neutralize the controls, allow the attitude to stabilize and readjust pitch attitude using the other pitch instruments.

4. Airspeed Indicator (ASI)

Airspeed is a function of power setting and attitude. In cruise, if the airspeed increases, pitch up. If it decreases, pitch down. Rapid changes in airspeed imply large changes of attitude; small changes represent small changes of attitude. An apparent lag may be observed when making attitude changes because it requires time to accelerate/decelerate. Departure from a constant airspeed due to an inadvertent attitude change results in an altitude change. For example, an increase in airspeed if the nose is low will lead to a decrease in altitude. Correcting the attitude will regain both the airspeed and the altitude.

BANK ATTITUDE CONTROL

The performance instruments used for bank control are:

1. Attitude Indicator

The rotor disc (miniature aircraft) on the attitude indicator displays changes in bank attitude. Banking is shown by the rotor disc assuming an angle in relation to the horizon bar and by the bank index pointer moving from the zero position to the angle of bank reference marks. Cyclic is used to tilt the rotor disc to the required angle of bank; the cyclic position has then to be maintained to hold the desired bank angle. The ball should remain centred during the turn. Small bank angles may not be readily detected on the attitude indicator, but can be determined by cross-reference to the heading indicator and turn and bank indicator or turn coordinator.

2. Heading Indicator

Although the heading indicator gives an immediate indication of turning, its primary purpose is to indicate heading, not bank angle. In co-ordinated flight, when the helicopter is banked, it turns. When the heading indicator shows a constant heading you are flying straight. Small bank angles show up as slow changes of heading; large changes as rapid heading changes. To correct an undesired turn, apply cyclic in the desired direction until the required heading is reached, maintaining co-ordinated flight with pedals. When initiating, or correcting a turn, use a bank angle less than the number of degrees off heading up to a maximum of a standard rate one turn.

3. Turn and Bank Indicator

- a) The turn needle indicates both direction and rate of turn. When the needle is left of centre, with the ball centred, the helicopter is turning left in co-ordinated flight. If the needle is right of centre, ball centred, the helicopter is turning right in co-ordinated flight. There is usually a mark on the face of the instrument to show the correct needle position for a rate one turn. Cyclic is used to initiate, maintain, and recover from turns. In turbulent conditions needle oscillations must be averaged to detect a turn.
- b) The ball functions as a result of gravity and centrifugal force. The needle and ball are interpreted together, the ball indicating if the helicopter is slipping or skidding. A slip is indicated when the ball is off centre toward the inside of the turn, and a skid if the ball is off centre toward the outside of the turn. If the ball is off centre it should be adjusted by pedal. A simple rule to remember is to step on the ball, ie. if the ball is off to the left press left pedal to centre it and vice versa. The ball helps in achieving correct co-ordination. Using the cyclic and pedals correctly in relation to each other realize accurate co-ordination in helicopters.

4. Turn Co-ordinator

This instrument displays the movement of the helicopter on the roll and yaw axis. It should be clearly understood that only the rate of roll and rate of turn are shown, not the actual bank angle.

TRIM

The inherent instability of helicopters requires the pilot to maintain the helicopter in trim as accurately as possible to minimize fatigue and reduce pilot workload. This is achieved by continual cross checking of the instruments using a radial scan. The yaw axis is the unstable in a single rotor helicopter and demands special attention from the pilot.

THE RADIAL SCAN

Performance must change before the performance instruments can react. The pilot must interpret any lag in instrument indications. If the performance instruments indicate that the heading or altitude is not as required, attention is directed to the control instruments while adjusting attitude and power sufficiently to make a correction. The pilot then confirms that the required correction is in progress by referring again to the performance instruments.

While flying with reference to instruments, the pilot continuously extracts information from the performance instruments, and makes control adjustments as required while referring to the control instruments. In extracting this information, the pilot focuses long enough on each instrument to read it. A split second is often long enough to extract the information and then the scan moves on to the next instrument. The attitude indicator is the central instrument. It becomes the hub of the scan so that the pilot's attention usually returns to it after looking at a particular performance instrument. A diagram depicting the path of the pilot's viewing pattern would show lines between the attitude indicator to the other instruments, just as spokes radiate from the hub of a wheel. This pattern of viewing the instruments is called a radial scan.

As part of using a radial scan, the pilot frequently scans those instruments that provide the information most needed, given the task at hand. The other instruments are scanned less frequently for backup information. A radial scan that uses particular instruments to get the information necessary to carry out a particular task is called the selective radial scan. For example, when the task is to fly straight and level, the most important performance instruments are the heading indicator and the altimeter. Therefore, the pilot would use the selective radial scan to focus on these two instruments more frequently. As shown in Fig. 30-2, the viewing pattern moves from the attitude indicator to the heading indicator, back to the attitude indicator, and from there to the altimeter.

Of the remaining performance instruments, the airspeed indicator and the vertical speed indicator give information to confirm the attitude; the turn co-ordinator and magnetic compass confirm direction. The selective radial scan uses the same, but less frequent, pattern for these instruments as it used for the altimeter and heading indicator.

APPLYING THE SCANNING PATTERN

To develop the technique of always referring to the right instrument at the right time, the pilot must continually ask the questions:

- What information do I need?
- What instruments give me the needed information?
- Is the information reliable?

Figures 30-2, -3, -4 and -5 show examples of scanning patterns that may be used for specific flight conditions.

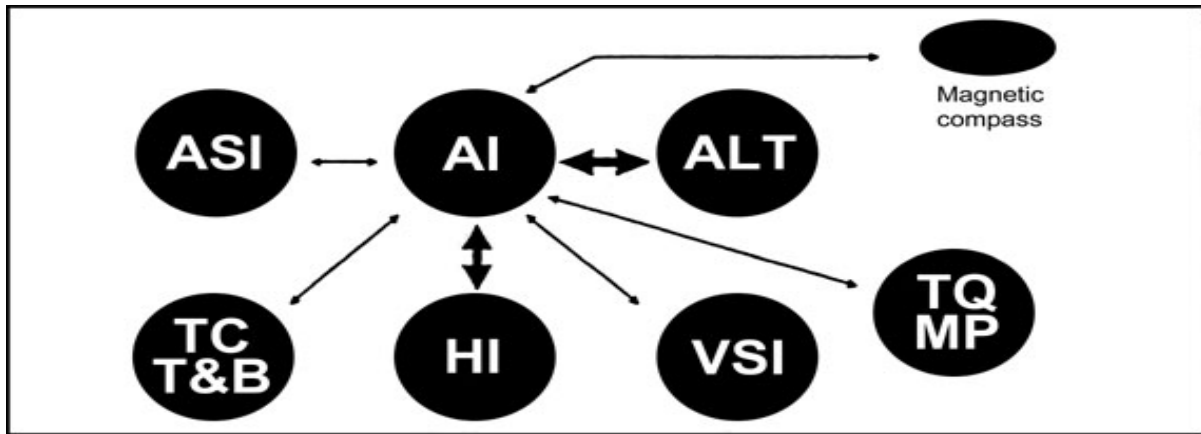

Figure 30-2: Straight and Level Flight

As noted above, Figure 30-2 depicts a selective radial scan pattern for straight and level flight. The answer to the question, What information do I need to fly straight and level?, is information on heading and altitude. The answer to the next question, Which instruments give me the needed information?, is the heading indicator and the altimeter. To answer the question, Is the information reliable?, the pilot must:

1. confirm the reliability of the heading indicator by referring to the compass and the turn and bank; and
2. confirm the reliability of the altimeter by referring to the vertical speed indicator and airspeed indicator.

In all four diagrams, the heavy arrows depict the scanning pattern the pilot uses most frequently to acquire the needed information. The light arrows indicate a less frequently repeated scan of the supporting instruments. This scan is used to confirm that the main instrument indications are reliable, and also to determine if there is any trend toward an undesired flight condition. The supporting instruments that are more relevant to the task at hand are viewed more frequently than the others. For example, when the pilot is more concerned about altitude control, the VSI would logically be more frequently viewed than the turn and bank indicator.

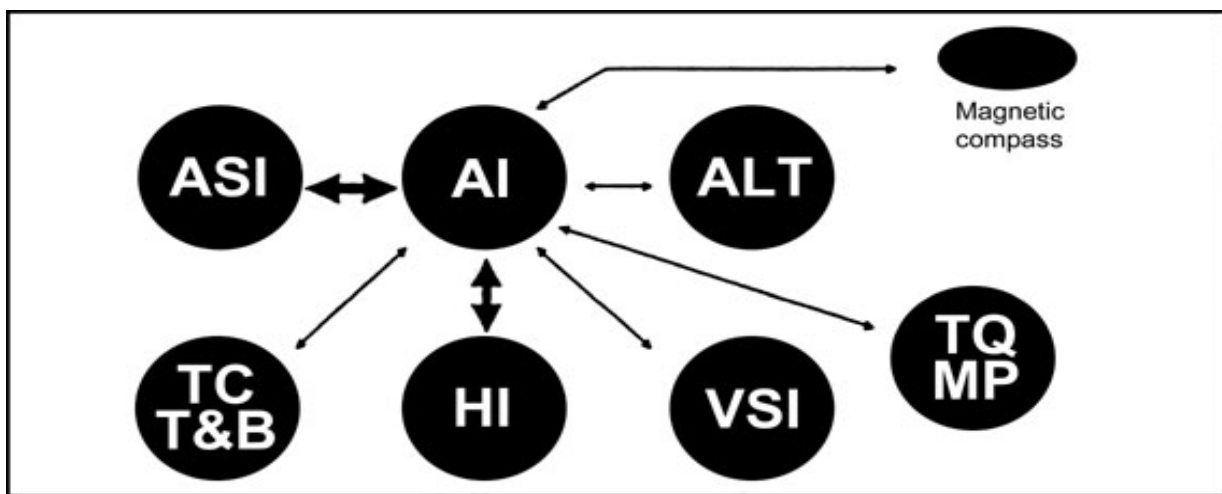

Figure 30-3: Straight Climb

Figure 30-3 shows the correct scanning pattern for the straight climb. The heavy arrows show that the pilot pays most attention to heading and airspeed while climbing. The light arrows depict the important (but less frequent) scan used to confirm heading and attitude information. For the straight climb, the pilot uses the turn and bank and magnetic compass to confirm the heading. The information from the VSI and altimeter confirms that the aircraft is performing as expected in the climb.

By interpreting the information on climb performance and power, the pilot can determine if the attitude indicator is reliable.

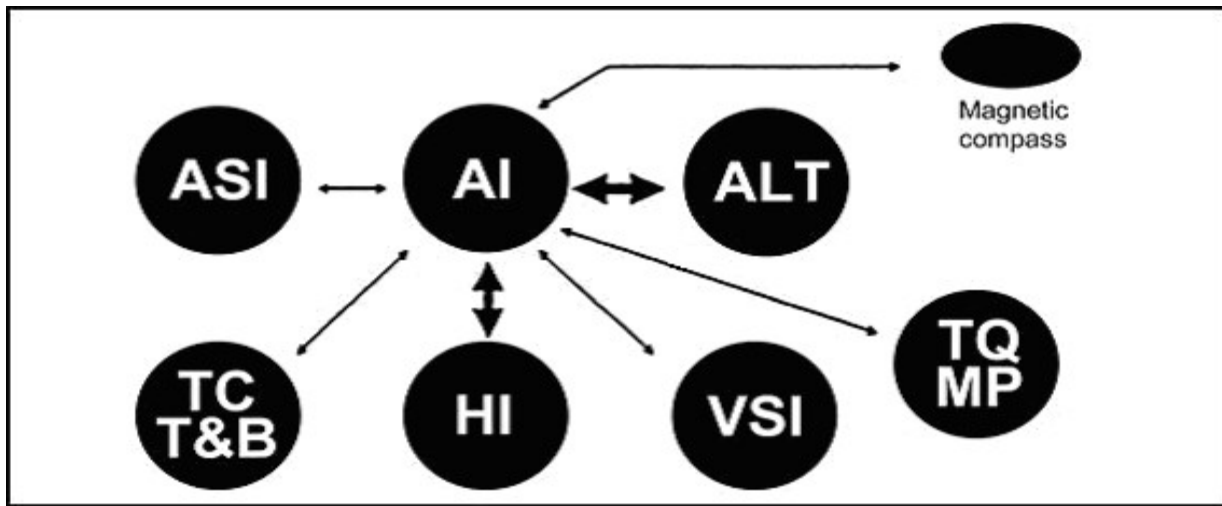

Figure 30-4: Approaching Desired Altitude

Figure 30-4 shows the most appropriate scan as the helicopter nears the assigned altitude. At this point, airspeed information becomes less important than the altitude information. During the transition from the climb to straight and level flight, the pilot uses the scan pattern that gives more frequent attention to the attitude indicator, with support from the heading indicator and altimeter.

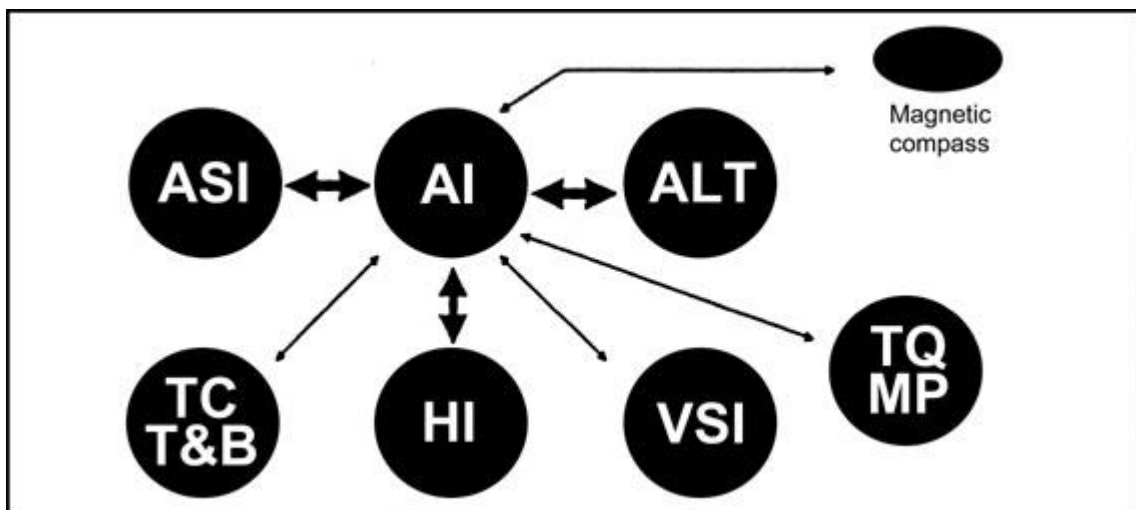

Figure 30-5: Level, Approaching Desired airspeed

As the cruise attitude is established, the pilot should allow the helicopter to accelerate to cruise speed before setting the cruise power. As shown in Figure 30-5, as the helicopter approaches the cruising attitude, airspeed information becomes more important, and the ASI is again scanned more often, along with the attitude indicator. The pilot also scans the heading indicator and altimeter often to establish and maintain cruise flight.

INSTRUMENT EXERCISES

STRAIGHT AND LEVEL FLIGHT

This consists of flying at a constant altitude (power setting), airspeed and heading (adjusted with cyclic). The rotor disc (miniature aircraft wings) should be level with the horizon on the attitude indicator if the instrument has been adjusted correctly.

When an instrument indicates an adjustment is required to maintain desired performance, the pilot will determine the necessary amount from other instruments. Airspeed, torque/MP, and/or altimeter indicate the adjustment to be made in power or attitude. Corrections to changes in attitude should be made as soon as noticed. Then instead of fixating on that particular instrument to note the effect, the scan is continued to finally return to the original instrument. In this way the entire panel reflects the effect of the adjustment.

Any deviation from the desired heading will be evident from the heading indicator. Immediate and smooth application of cyclic is used to return to the desired heading.

Small attitude and heading excursions when promptly corrected maintain good attitude control. After adjusting, scan the other performance instruments to verify the correction.

During cruise flight, if altitude cannot be maintained with cyclic, without exceeding airspeed changes of plus or minus 10 knots, power is used.

CLIMB

- a) The climb is performed using the attitude-power-trim (APT) technique. Climb attitude is set using cyclic, then the power is adjusted by raising the collective to produce and maintain a 500 ft/min. rate of climb. As power is increased, the pedals must be adjusted to remain in co-ordinated flight.
- b) During the climb, the heading, attitude, and airspeed are maintained by cyclic; rate of climb by collective; and trim by pedals. A lead of 10% of the rate of climb is generally accepted as the point to begin levelling off at the desired altitude. This amount can vary with the aircraft, rate of climb, and pilot technique.
- c) Normal cruise is resumed using the attitude-power-trim technique. Cyclic to establish the attitude for the normal cruise airspeed, collective to set cruise power, and pedals to maintain co-ordinated flight.

DESCENTS

- a) Descents are entered using the power-attitude-trim (PAT) technique. Lowering the collective to reduce the power to a setting that gives the desired rate of descent, usually 500 ft/min. Cyclic is adjusted to set the required attitude, and co-ordinated flight maintained by pedals.
- b) Once established at a constant rate of descent, fine adjustments are made using collective pitch (power) changes.
- c) Normal cruise is resumed using the power-attitude-trim technique once more. Prior to levelling off at the desired altitude, cruise power is applied to stop the downward movement through that altitude. A lead of 10% of the vertical rate of descent is normally required, i.e. 50 feet for 500 fpm.
- d) The cruise attitude is set with cyclic, trim using pedals, and a scan started to establish level flight.

TURNS

An angle of bank of 15 to 20 degrees should not be exceeded for this exercise. Steep turns will be explained and practised for familiarization purposes.

To enter a turn, the cyclic is eased in the direction required. The initial bank is started with reference to the attitude indicator. When the desired angle of bank is reached, cyclic control pressure is held to maintain the angle of bank, but relaxed somewhat to prevent over bank. Easing the cyclic in the direction opposite to the turn will return the helicopter to straight and level flight. When doing this reference should be made to all available instruments.

Climbing and descending turns use the same technique, but usually the helicopter is established in the climb, or descent, before turning.

Turns to a specified heading should be made in the shortest direction referring to the heading indicator. Since the helicopter will continue to turn as long as the bank is held, roll out must be started before reaching the desired heading. The amount of lead used should be half the angle of bank. The technique is the same as above, except the cyclic is applied on reaching the lead heading.

The rate of 360 degrees in 2 minutes (3 degrees per second) is the standard rate turn. All timed turns are based on these criteria. The position of the sweep hand must be noted, or started, when the turn is initiated. For ease in timing, start the time when the sweep hand passes the 3, 6, 9, or 12 o'clock position. The standard rate of turn is maintained for the predetermined time and then the roll out is started.

Any turn with more than 20° of bank is considered a steep turn. Although they are seldom necessary or advisable in IMC, students will be familiarized with steep turns. This is to ensure they recognize and react quickly and smoothly to large changes in the helicopter's attitude. The procedures are identical to any other turn manoeuvre, cyclic controlling rate of turn and attitude, collective controlling altitude and airspeed.

UNUSUAL ATTITUDES

To recover from an unusual attitude, the pilot corrects the pitch and bank attitude, adjusts power, and trims the helicopter as necessary. The bank attitude is corrected with reference to the turn and bank indicator, then the ball is centred, the airspeed checked and corrected, then the power if required. Once the helicopter is near to straight and level flight, a thorough scan of all the instruments is then completed and adjustments are made as necessary.

RULE OF THUMB:

The procedure for recovery from unusual attitudes can be easily remembered by following the order of actions listed below:

NEEDLE

BALL

AIRSPEED

POWER

EMERGENCIES/MALFUNCTIONS

1. Partial Panel

a) Failed Attitude Indicator

If the attitude indicator fails, the primary pitch and roll references are lost. The control instruments for indicating pitch become the ASI and the altimeter. The turn needle becomes the heading indicator (performance instrument) as required. The VSI is too sensitive for indicating pitch changes and should be used as a trend instrument only. When correcting the pitch attitude the helicopter is approximately level when the VSI or ASI reverse direction of movement.

b) Failed Heading Indicator

If the heading indicator fails in flight, all reference to heading must be accomplished using the magnetic compass. Use of standard rate turns, and timed turns partial panel, are used to make heading changes.

2. Autorotative Descent

If an autorotation is required, the pilot should use the appropriate airspeeds dependent on the manufacturer's recommended procedures. It is imperative to conserve Rotor RPM by smoothly lowering the collective immediately. Control and performance instruments should be closely monitored, particular attention being paid to establishing and maintaining co-ordinated flight. A turn should be made into the last known or forecast wind.

The airspeed used is usually the minimum rate of descent speed for that particular type.

Once established in autorotation, normal emergency procedures are followed, (Mayday, fuel off, etc.) Rotor RPM should be included in the crosscheck especially during turns. Returning to visual reference will be dependent on cloud base. If other crew or passengers are carried they can be invaluable sources of information as to when the ground is visible. Final descent to touchdown can only be achieved visually.

3. All other emergencies or failures are handled in accordance with the manufacturer's flight manual

EXERCISE 31 - NIGHT FLYING #1

In this series of exercises you will learn how to fly VFR at night. This does not involve any new flying skills, but there are new sensations and visual cues to which you have to become accustomed. The ideal exercise to accomplish this is the circuit. There is nothing mysterious about flying at night but, because of the lack of outside references, you will rely more on the flight instruments.

In preparation for night flying you should allow time to accustom your eyes to the darkness; it will take approximately 30 minutes for them to adapt in the dark. Try to avoid bright lights during this time.

PLANNING

1. **Weather.** Prior to night flying, a good weather briefing is vital. Most companies have their own limits for night, usually they are a little higher than by day. The company operations manual addresses this subject. During the day, there is little possibility of flying into cloud by accident, but on a dark night it can be done quite easily.
2. **Heliport/Airport Familiarization.** Familiarize yourself with the lighting systems in use at the heliport or airport in use. Heliport night lighting consists of a minimum of 8 yellow or green lights around the perimeter of the take-off and landing area. Airports look different at night and the lighting includes lights for the runway, threshold, approach, taxiway, ramp and rotating beacons. Colours are used to identify them; the threshold lights are green, taxi are blue, and obstruction are red. The intensity of approach and runway lights can be varied at most airports, and strobe lighting if it is either distracting, or disorientating, can be switched off if not required.
3. **Pre-Flight Inspection.** It is difficult to do an effective pre-flight in the dark, so always perform the inspection before dark or in a well-lit hangar, resort to a flashlight only as a last resort. Cockpit, position and landing lights must be checked for correct operation prior to flight, adjust the landing light if necessary. Ensure all electrical systems, lights and instruments are fully serviceable. You also have to carry a serviceable flashlight in the event of electrical failure.
4. **Other Traffic.** Know how to interpret the position lights of other aircraft so you can determine their location and direction of movement relative to yourself.
5. **Aircraft Checks.** Pre-start and start checks are normal except that lights are on and beacon operating as a precaution to anyone close by that you are about to start. Cockpit lights should illuminate all engine and flight instruments and be adjusted so as not to create a glare that interferes with vision. On shutdown, keep position and beacon lights selected 'ON' until the rotor stops completely.

CIRCUITS

Circuits are a good introduction to night flying because they cover all of the basic exercises. Night techniques are as follows:

1. takeoffs and landings. These are performed in the same manner as by day and should be practised with and without landing lights. When not using the landing light use a good outside reference such as a taxiway or runway light. Before taking off, if ground crew are present, switch on the landing light. This indicates you are about to take off. Flashing the landing light indicates a crewman may approach, or leave the helicopter, or that you require the assistance of a crewman;
2. hover and hover-taxi. Hover and hover-taxi higher and slower than by day for the following reasons;
 - a) depth perception is less acute and it will be more difficult to judge your height and detect slight movement over the ground;
 - b) speed is deceptive because your peripheral vision has fewer references; as a result there is a tendency to hover-taxi too fast;
 - c) distance at night is also deceptive when judged by stationary lights which are nearer than they appear to be; and
 - d) a more careful lookout is required to avoid obstructions.

when hovering or hover-taxiing the landing light can produce glare and disorientation particularly over light coloured surfaces such as concrete. If you cannot adjust the beam, it is sometimes preferable not to use the light if there is adequate outside visual reference. The position of some anti-collision lights can also cause disorientation when the beam is reflected off ice crystals, light snow or light rain;
3. transitions from hover to forward flight. A towering takeoff is normally used for night flying. A rate of climb should be initiated before moving into forward flight and maintained throughout the transition. Use a reference point which coincides with the take-off heading if available;
4. climb-out, cross-wind and downwind. These are the same as for day except that you will make more frequent reference to the instruments to verify attitude, altitude, heading and airspeed; and
5. transitions from forward flight to the hover. Night approaches are made to a lighted area such as a runway, taxiway or heliport. On the final approach identify the landing point and carry out an accurate constant angle approach. The transition from approach to the hover is more difficult than by day because outside reference may be obscure, and groundspeed is more difficult to assess. Be sure to look out the side of the helicopter more frequently to check the rate of deceleration, as height decreases ground references become clearer.

EMERGENCIES

1. In the event of an emergency requiring an autorotation, employ the following sequence:
 - a) enter autorotation;
 - b) if possible, turn into last known wind;
 - c) switch on landing light;
 - d) select speed for constant attitude autorotation;
 - e) transmit "Mayday" if time permits;
 - f) choose area for touchdown; and
 - g) flare, cushion landing with collective.
2. Constant attitude autorotations may be used effectively at night. These are useful because they require minimum or no flare for a skids level attitude on touchdown, and the landing light remains effective throughout the landing sequence.
3. Other emergency procedures, which do not require an autorotation, are the same as by day. You must carry a serviceable flashlight in case of electrical failure.
4. Bear in mind that at night it will be more difficult to select a suitable landing area, usually lighter areas are clearer than darker areas. This is particularly true in winter operations where open fields stand out extremely well, as do ice covered lakes.
5. In case of disorientation or loss of visual reference, revert to flying by instruments, followed by a gentle 180 degree turn in order to regain visual reference to the ground.

EXERCISE 31 - NIGHT FLYING #2

INTRODUCTION

The principles of pilot navigation by night are basically similar to those used by day, except that map reading at night requires some special techniques.

PLANNING

A complete weather briefing and accurate pre-flight planning are even more important than by day. When examining the route, pay particular attention to the elevation of the terrain including any hills, peaks, or other obstructions such as towers. The minimum en-route altitude should be the cruising altitude appropriate to the aircraft track when flying greater than 3000 feet AGL. It is recommended that cruising altitudes be at least 1000 feet above the Maximum Elevation Figure (MEF) for the over flown sectors.

EN ROUTE

The following points in pilot navigation by night call for special consideration:

1. navigation features such as railways and country roads will generally not be visible to the pilot unless the ground is snow covered or there is a bright moon. At the same time, cities and towns will often be visible from a greater distance. Therefore, for visual night navigation, greater stress should be placed on positively identifiable lighted features such as cities and towns, large lakes or rivers;
2. the ability to map read will be dependent on the weather and the moon. Ground features show up better when viewed against the moon. Avoid depending on small lights on the ground for fixes, the scattered lights around a small community can easily give the impression of a much larger town;
3. all compass headings should be accurately maintained and corrections made only when the position, fixed by check points or radio aids, is absolutely certain;
4. accuracy in time keeping is essential; and
5. radio aids can be effectively used for night navigation.

Your instructor will select a route for initial pilot navigation practice that includes 3 or more legs with landmarks that are identifiable at night.